



Edward Cast Steel Valves



Experience In Motion



This page intentionally left blank.

Table of Contents

Figure Number Index	5
Edward Valves Availability Chart	6
Edward Description of Figure Number System	8

Introduction

High Performance for Critical Service	10
A History of Firsts	13
Miscellaneous Technical Data	14
Special Application Valves	15
Special Application Valves	16
Features and Description of Edward Flite-Flow® Globe Valves	17
Parts Specification List for Globe Valves Stop, Stop-Check & Piston Lift Check	18
Features and Description of Edward Stop-Check (Non-Return) Valves	19
Features and Description of Edward Check Valves	20
Features and Descriptions of Edward One-Piece Tilting Disk Check Valves	21
Parts Specification List for Edward One-Piece Tilting Disk Check	22
Features and Description of Edward Equiwedge® Gate Valves	23
Parts Specification List for Gate Valves	24
Features and Description of Edward Equiwedge® Gate Valves	25
Center Cavity Overpressurization	25

Cast Steel Valves

Stop Valves Class 300	26
Stop-Check (Non-Return) Valves Class 300	28
Check Valves Class 300	30
Stop Valves Class 400	32
Stop-Check (Non-Return) Valves Class 400	33
Check Valves Class 400	34
Stop Valves Class 600	35
Stop-Check (Non-Return) Valves Class 600	39
Check Valves Class 600	41
Stop Valves Class 700	43
Stop-Check (Non-Return) Valves Class 700	44
Check Valves Class 700	45
Stop Valves Class 900	46
Stop-Check (Non-Return) Valves Class 900	50
Check Valves Class 900	52
Stop Valves Class 1100	55
Stop-Check (Non-Return) Valves Class 1100	56
Check Valves Class 1100	57
Stop-Check & Check Valves Elbow Down	58
Stop Valves Class 1500	59

Stop-Check (Non-Return) Valves Class 1500	63
Check Valves Class 1500	65
Stop Valves Class 1800	69
Stop-Check (Non-Return) Valves Class 1800	70
Check Valves Class 1800	71
Stop Valves Class 2000	72
Stop-Check (Non-Return) Valves Class 2000	73
Check Valves Class 2000	74
Stop Valves Class 2500	75
Stop-Check (Non-Return) Valves Class 2500	79
Check Valves Class 2500	81
Stop Valves Class 2900	84
Stop-Check (Non-Return) Valves Class 2900	85
Check Valves Class 2900	86
Stop Valves Class 3600	87
Stop-Check (Non-Return) Valves Class 3600	90
Check Valves Class 3600	91
Stop Valves Series 4500	92
Stop Check (Non-Return) Valves Series 4500	93
Check Valves Series 4500	94
Check Valves Class 4500	95

Accessories/Actuators

Accessories	96
Accessories – Cast Steel	97
Actuators – Cast Steel	99
Required Information for Motor Actuators	100

Reference

Material Chemical Analysis (ASTM) for Edward Valves	101
ASME B16.34 – 2004 Pressure/Temperature Ratings	102-117

Technical Information

1. Stop and Check Valve Applications Guide	118
1.1 Stop Valve Applications	118
1.1.1 Stop Valve Types and Typical Uses	118
1.1.2 Throttling Characteristics of Edward Stop Valves	120
1.1.3 Stop Valve Actuators and Accessories	121
1.1.4 By-Passes and Drains	122
1.1.5 Stop Valve Application Chart	123
1.2 Check Valve Applications Guide	124
1.2.1 Check Valve Types and Typical Uses	124
1.2.2 Check Valve Applications Chart	127
1.3 Check and Stop-Check Valve Installation Guidelines	128
1.3.1 Adjacent Flow Disturbances	130
1.3.2 Other Problem Sources	132
1.4 Check Valve Performance	132
1.4.1 Check Valve Seat Tightness	132
1.4.2 Pressure Surge and Waterhammer	133
1.4.3 Check Valve Accessories and Special Features	136
1.4.4 Check/Stop-Check Valve Periodic Inspection and Preventive Maintenance	136
2. Flow Performance	137
2.1 Choose the Best Valve Size for Your Service Conditions	137
2.1.1 Pressure Drop, Sizing and Flow Rate Calculations – Fully Open Valves – All Types	137
2.2 Basic Calculations	138
2.2.1 Pressure Drop	138
2.2.2 Required Flow Coefficient	138
2.2.3 Flow Rate	139
2.2.4 Inlet Flow Velocity	139
2.3 Corrections Required with Large Pressure Drops	139
2.3.1 Gas and Steam Flow	139
2.3.2 Liquid Flow – Cavitation and Flashing	140
2.4 Check Valve Sizing	141
2.4.1 Sizing Parameter	141
2.4.2 Calculations for Check Valves Less Than Fully Open	142
2.4.3 Sizing Guidelines	142
2.5 Pipe Reducer Coefficient	143
2.5.1 Pipe Geometry Factor	144
2.5.2 Other Coefficients	144
Table 1 – Edward Cast Steel Globe Flow Coefficients	145
Table 2 – Edward Cast Steel Angle Valve Flow Coefficients	148
Table 3 – Edward Cast Steel Flite-Flow Stop and Stop-Check Valve Flow Coefficients	151
Table 4 – Edward Cast Steel Tilting Disc Check Valve Flow Coefficients	154
Table 5 – Edward Cast Steel Equiwedge Gate Valve Flow Coefficients	157

3. Edward Valve Design Standards and Features	162
3.1 Codes and Standards	162
3.2 Pressure Ratings	162
3.3 Pressure-Seal Construction	163
3.4 Hardfacing	164
3.5 Valve Stem Packing	164

Maintenance

On-site Field Service Repair Capabilities	165
---	-----

References to Related Brochures

Brochure	Document Number
Forged Steel Valves	EVENCT0001
Cast Steel Valves	EVENCT0002
Nuclear Application Valves	EVENCT0004

Figure Number Index

Figure	Forged	Cast	Nuclear	Figure	Forged	Cast	Nuclear	Figure	Forged	Cast	Nuclear	Figure	Forged	Cast	Nuclear
158	57			• 970Y		52,53	62,63	• 4017		46,47	56,57	16018	67		
158Y	57			1028	36			• 4017Y		46,47	56,57	35125	27		
160	58			1029	36			• 4092		52,54	62,64	35129	27		
160Y	58			1032	41			• 4092Y		52,54,57	62,64	35225	27		
238	63			1032Y	41			• 4094		52	62	35229	27		
238Y	63			1038	40			• 4094Y		52	62	• 36120	42		
303		28		1038Y	40			• 4095		52,53	62,63	• 36122	35		
303Y		28		1046	38			• 4095Y		52,53	62,63	• 36124	26,42,60		42
304		28		1047	38			• 4302Y		50,51,56	60,61	• 36125	45		
304Y		28		1048	37			• 4306Y		50	60	• 36128	26,42,60		42
318		26		1048Y	37			• 4307Y		50,51	60,61	• 36129	45		
318Y		26		1049	37			• 4314Y		46,47,55	56,57	• 36160	43		
319		26		1049Y	37			• 4316Y		46	56	• 36164	43		43
319Y		26		1058	40			• 4317Y		46,47	56,57	• 36165	46		
329		26		1068	39			• 4370Y		52,53	62,63	• 36168	43		43
329Y		26		1068Y	39			• 4392Y		52,54,57	62,64	• 36169	46		
338	63			1069	39			• 4394Y		52	62	• 36170	44		
338Y	63			1069Y	39			• 4395Y		52,53	62,63	• 36174	44		44
391		30		• 1302		29		• 4402Y		79,80,85		• 36175	47		
391Y		30		• 1302Y		29,33		• 4406Y		79		• 36178	44		44
394		30		• 1314		27		• 4407Y		79,80		• 36179	47		
394Y		30		• 1314Y		27,32		• 4414Y		75,76,84		• 36220	42		
393		30		1324	27			• 4416Y		75		• 36222	35		
393Y		30		1324Y	27			• 4417Y		75,76		• 36224	26,42,60		42
• 602		40	53	1390	31			4448Y		58		• 36225	45		
• 602Y		40,44	53	1390Y	31			• 4470Y		81,83		• 36228	26,42,60		42
604		39	52	1392	31			• 4492Y		81,82,86		• 36229	45		
604Y		39	52	1392Y		31,34		• 4494Y		81		• 36260	43		
605		39	52	1441	22,23			• 4495Y		81,82		• 36264	43		43
605Y		39	52	1441Y	22,23			4498Y		58		• 36265	46		
606		39	52	1443	22,23			4502Y		93		• 36268	43		43
606Y		39	52	1443Y	22,23			4514Y		92		• 36269	46		
607		39	52	• 1570Y		68	74	4570Y		95		• 36270	44		
• 607Y		39	52	• 1611		37,38	50,51	4592Y		94		• 36274	44		44
• 614		36	49	• 1611BY		37,38	50,51	5002Y		93		• 36275	47		
• 614Y		36,43	49	• 1611Y		37,38	50,51	5014Y		92		• 36278	44		44
616		35	48	1641	24,25			5070Y		95		• 36279	47		
616Y		35	48	1641Y	24,25			5092Y		94		• 66120	48		
617		35	48	1643	24,25			5158	57			• 66124	26,48,61		45
• 617Y		35	48	1643Y	24,25			5160	58			• 66125	51		
618		35	48	• 1711BY		37,38	50,51	• 7502Y		63,64,70	69,70	• 66128	26,48,61		45
618Y		35	48	• 1711Y		37,38	50,51	• 7506		63	69	• 66129	51		
619		35	48	• 1911		48,49	58,59	• 7506Y		63	69	• 66160	49		
619Y		35	48	• 1911BY		48,49	58,59	• 7507		63,64	69,70	• 66164	49		46
• 670Y		41,42	54,55	• 1911Y		48,49	58,59	• 7507Y		63,64	69,70	• 66165	52		
690		41	54	• 2002Y		63,64,70	69,70	• 7514Y		59,60,69	65,66	• 66168	49		46
690Y		41	54	• 2006Y		63,64	69	• 7516		59	65	• 66169	52		
691		41	54	• 2007Y		63,64	69,70	• 7516Y		59	65	• 66170	50		
691Y		41	54	• 2014Y		59,60,69	65,66	• 7517		59,60	65,66	• 66174	50		47
• 692		41,42	54,55	• 2016Y		59	65	• 7517Y		59,60	65,66	• 66175	53		
• 692Y		41,42,45	54,55	• 2017Y		59,60	65,66	7548Y		58		• 66178	50		47
694		41	54	• 2070Y		68	74	• 7592Y		65,67,71	71,73	• 66179	53		
694Y		41	54	• 2092Y		65,67,71	71,73	• 7594		65,66	71,72	• 66220	48		
695		41	54	• 2094Y		65,66	71,72	• 7594Y		65,66	71,72	• 66224	26,48,61		45
695Y		41	54	• 2095Y		65,66	71,72	• 7595		65,66	71,72	• 66225	51		
• 702Y		40,44	53	• 2570Y		81,83		• 7595Y		65,66	71,72	• 66228	26,48,61		45
706Y		39	52	3602Y		90,91		7598Y		58		• 66229	51		
707Y		39	52	• 3902Y		79,80,85		9158	57			• 66260	49		
• 714Y		36,43	49	• 3906		79		9160	58			• 66264	49		46
716Y		35	48	• 3906Y		79		• 11511		61,62	67	• 66265	52		
717Y		35	48	• 3907		79,80		• 11511Y		61,62	67,68	• 66268	49		46
• 770Y		41,42	54,55	• 3907Y		79,80		• 11511BY		61,62	67,68	• 66269	52		
• 792Y		41,42,45	54,55	• 3914Y		75,76,84		• 12011Y		61,62	67,68	• 66270	50		
794Y		41	54	• 3916		75		• 12011BY		61,62	67,68	• 66274	50		47
795Y		41	54	• 3916Y		75		• 12511		77		• 66275	53		
• 828	28			• 3917		75,76		• 12511Y		77		• 66278	50		47
• 829	28			• 3917Y		75,76		• 12511BY		77,78		• 66279	53		
832	34			• 3992Y		81,82,86		• 14311Y		48,49	58,59	96124	54,62		
832Y	34			• 3994		81		• 14311BY		48,49	58,59	96128	54,62		
• 838	33		41	• 3994Y		81		• 14411BY		77,78		96164	55		
• 838Y	33		41	• 3995		81,82		• 14411Y		77		96168	55		
• 846	29			• 3995Y		81,82		• 15004			19	96174	56		
• 847	29			• 4002		50,51	60,61	• 15008			19	96178	56		
• 848	31		39	• 4002Y		50,51,56	60,61	• 15014			19	96224	54,62		
• 848Y	31		39	• 4006		50	60	• 15018			19	96228	54,62		
• 849	31		39	• 4006Y		50	60	• 15104			19	96264	55		
• 849Y	31		39	• 4007		50,51	60,61	• 15108			19	96268	55		
• 858	30			• 4007Y		50,51	60,61	• 15114			19	96274	56		
• 868	32		40	• 4014		46,47	56,57	• 15118			19	96278	56		
• 868Y	32		40	• 4014Y		46,47,55	56,57	16004	67			DSXXXX	60,61,62		
• 869	32			• 4016		46	56	16008	67			DEXXXX	60,61,62		
• 869Y	32			• 4016Y		46	56	16014	67			DCXXXX	60,61,62		

• These valves can be constructed for nuclear service.

Note: See "References to Related Brochures" chart in the Table of Contents to locate figures that do not appear in this brochure.



Edward Valves Availability Chart

Edward Cast Steel Gate, Globe, Angle and Check Valves

Description	Pressure Rating ^{1,2}	Size ²	Ends	Page
Bolted Bonnet Globe and Angle Valves, Stop and Stop-Check (Non-Return) and Bolted Cover Piston Check	ASME 300(50)	2-½(65) thru 12(300)	Buttwelding or Flanged	26, 28, 30
	ASME 600(110)*	2-½(65) thru 69(150)		35, 38, 41
Pressure Seal Bonnet Globe and Angle Valves Stop and Stop-Check (Non-Return)	ASME 600(110)*	8(200) thru 14(350)	Buttwelding or Flanged	35, 38
	ASME 900(150)*	3(80) thru 24(600)		46, 47, 50, 51
	ASME 1500(260)* & 2500(420)	2-½(65) thru 24(600)		59, 60, 63, 75, 79, 80, 81, 82
Pressure Seal Cover, Piston Check Valves	ASME 600(110)*	8(200) thru 14(350)	Buttwelding or Flanged	42
	ASME 900(150)*	8(200) thru 24(600)		52
	ASME 1500(260)* & 2500(420)	2-½(65) thru 24(600)		65, 66, 81, 82
Equiwedge® Gate Valves	ASME 600(110)* & 900(150)*	2-½(65) thru 32(800)	Buttwelding or Flanged	37, 38, 48, 49
	ASME 1500(260)* & 2500(420)	2-½(65) thru 24(600)		61, 62, 77, 78
	ASME 3600	16(400) thru 24(600)	Buttwelding	88, 89
Flite-Flow® Globe Valves, Stop and Stop-Check (Non-Return)	ASME 300(50)	3(80) thru 16(400)	Buttwelding or Flanged	27, 29
	ASME 400(68)	3(80) thru 4(100)		32, 33
	ASME 600(110)*	3(80) thru 32(800)		36, 40
	ASME 700(120)	6(150) thru 32(800)		43, 44
	ASME 900(150)*	6(150) thru 16(400)		47, 51
	ASME 1100(190)	3(80) thru 4(100)		55, 56
	ASME 1500(260)* & 2500(420)	3(80) thru 24(600)		60, 64, 76, 80
	ASME 1800(310) & 2900 (490)	3(80) thru 4(100)	69, 70, 84, 85	
	ASME 2000(340)	12(300) thru 14(350)	Buttwelding	72, 73
	ASME 3600	16(400) thru 24(600)		87, 90
	Series 4500	4(100) thru 10(250)	Buttwelding or Flanged	92, 93
Flite-Flow® Piston Check Valves	ASME 300(50)	2-½(65) thru 16(400)	Buttwelding or Flanged	31
	ASME 400(68)	3(80) thru 4(100)		34
	ASME 600(110)*	3(80) thru 32(800)		42
	ASME 700(120)	3(80) thru 4(100)		45
	ASME 900(150)*	3(80) thru 16(400)		54
	ASME 1100(190)	3(80) thru 4(100)		57
	ASME 1500(260)* & 2500(420)	3(80) thru 24(600)		67, 82
	ASME 1800(310) & 2900 (490)	3(80) thru 4(100)	71, 86	
	ASME 2000(340)	12(300) thru 14(350)	74	
	ASME 3600	16(400) thru 24(600)	Buttwelding	91
	Series 4500	4(100) thru 10(250)	Buttwelding or Flanged	94
Tilting Disk Check Valves	ASME 600(110)*	6(150) thru 20(500)	Buttwelding	42
	ASME 900(150)*, 1500(260)* & 2500(420)	2-½(65) thru 24(600)		53, 68, 83
	Class 4500(760)	6(150) & 8(200)		95
Nuclear Valves	Thru ASME 2500(420)*	to Size 32(800)	Buttwelding	See Nuclear Catalog
Special Application Valves	Thru ASME 2500(420)	to Size 18(450)	As Required	58

Note: "References to Related Brochures" chart in the Table of Contents to locate valves that do not appear in this brochure.

*These valves can be constructed and supplied for nuclear service.

1. See 3.2 Pressure Ratings in the Technical Information section of this brochure for definition of various pressure ratings available.

2. Metric equivalent values for ratings and sizes are in parentheses.

Edward Valves Availability Chart

Edward Forged Steel, Globe, Angle, and Check Valves

See Edward Forged Steel Valve Catalog for detailed information (EVENCT0001)

Description	Pressure Rating ^{1,2}	Size ²	Ends	Page
Globe Stop Valves	ASME 600(110)*	½(15) thru 2(50)	Flanged	28
	ASME 800(130)	¼(6) thru 2(50)	Threaded, Socket	31
	Series 1500	½(15) thru 2(50)	Threaded, Socket, Flanged	36,37
Univalve Globe Stop Valves	ASME 1690(290)* ASME 2680(460)* ASME 4500(760)	½(15) thru 4(100)	Threaded, Socket, Buttwelding	42,48,54
Hermavalue Globe Stop Valves	ASME to 1690(290)*	½(15) thru 2-½(65)	Socket, Buttwelding	64-67
Blow Off Stop Valves	ASME 300(50), 400(68) & 600(110)	1-½(40) thru 2-½(65)	Socket, Flanged, Buttwelding	22-25
	ASME 1500(250) & 2500(420)		Socket, Buttwelding	26
Hydraulic Stop Valves	5,000 PSI CWP 10,000 PSI CWP	¼(6) thru 2(50)	Threaded, Socket, Flanged	57
Globe Stop-Check Valves	ASME 600(110)*	½(15) thru 2(50)	Flanged	29
	ASME 800(130)	¼(6) thru 2(50)	Threaded, Socket	32
	Series 1500	½(15) thru 2(50)	Threaded, Socket, Flanged	38,39
Univalve Globe Stop-Check Valves	ASME 1690(290)* ASME 2680(460)* ASME 4500(760)	½(15) thru 4(100)	Threaded, Socket, Buttwelding	43,49,55
Piston Check Valves	ASME 600(110)*	½(15) thru 2(50)	Flanged	30
	ASME 800(130)	¼(6) thru 2(50)	Threaded, Socket	33
	Series 1500	¼(6) thru 2(50)	Threaded, Socket, Flanged	40
PressurCombo	ASME 1690*, 2680* & 4500	½(15) thru 4(100)	Socket, Buttwelding	59-62
Univalve Piston Check Valves	ASME 1690(290)* ASME 2680(460)* ASME 4500(760)	½(15) thru 4(100)	Threaded, Socket, Buttwelding	44,50,56
Hydraulic Check Valves	5,000 PSI CWP & 10,000 PSI CWP	¼(6) thru 2(50)	Threaded, Socket, Flanged	58
Ball Check Valves	ASME 800(130)	¼(6) thru 2(50)	Threaded, Socket	34
	Series 1500			41
Strainers	ASME 800(130) & Series 1500	¼(6) thru 2(50)	Threaded, Socket	63
Flanged Univalve	Class 1500(260)	½(15) thru 2(50)	Flanged	35
Univalve Angle Stop, Stop-Check and Check Valves	ASME 1690(290)	½(15) thru 4(50)	Socket, Buttwelding	45-47
	ASME 2680(460)			51-53
Continuous Blowdown Valves	ASME 1925	1(25) thru 4(100)	Socket, Buttwelding	27
Nuclear Valves	Thru ASME 2500(420)*	to Size 32(800)	Buttwelding	See Nuclear Catalog

Note: See "References to Related Brochures" chart in the Table of Contents to locate valves that do not appear in this brochure.

1. See 3.2 Pressure Ratings in the Technical Information section of this brochure for definition of various pressure ratings available.

2. Metric equivalent values for ratings and sizes are in parentheses.

*These valves can be constructed and supplied for nuclear service.

Edward Description of Figure Number System

Special Material Suffixes

CF8C	Cast 18-8 stainless steel (type 347) body and bonnet. Parts in contact with line fluid either cast or forged 18-8 stainless steel or equivalent.
CF3M	Cast 18-8 stainless steel (type 316L) body and bonnet. Parts in contact with line fluid either cast or forged 18-8 stainless steel or equivalent.
CF8M	Cast 18-8 stainless steel (type 316) body and bonnet. Parts in contact with line fluid either cast or forged 18-8 stainless steel or equivalent.
C5	Cast chromium molybdenum (5 chromium ½ molybdenum) Grade C5 alloy steel body and bonnet. Trim of equal or higher grad alloy steel.
F11	Body and bonnet of forged chromium molybdenum (1-¼ chromium, ½ molybdenum) Grade F11 alloy steel.
F22	Body and bonnet of forged chromium molybdenum (2-¼ chromium, 1 molybdenum) Grade F22 alloy steel.
F91	Body and bonnet of forged chromium molybdenum (9 chromium, 1 molybdenum) Grade F91 alloy steel.
F316	Body and bonnet of forged Type 316 stainless steel.
F316L	Body and bonnet of forged Type 316L stainless steel.
F347	Body and bonnet of forged Type 347 stainless steel.
F347H	Body and bonnet of forged Type 347H stainless steel.
LF2	Forged carbon steel material on which Charpy impact tests have been performed on forging heat to determine low temperature properties.
WC1	Cast carbon molybdenum Grade WC1 body and bonnet.
WC6	Cast chromium molybdenum (1-¼ chromium, ½ molybdenum) Grade WC6 alloy steel body and bonnet.
WC9	Cast chromium molybdenum (2-¼ chromium, 1 molybdenum) Grade WC9 alloy steel body and bonnet.
WCB	Cast carbon steel Grade WCB body and bonnet.
WCC	Cast carbon steel Grade WCC body and bonnet.
C12A	Cast chromium molybdenum (9 chromium, 1 molybdenum) alloy steel body and bonnet.

Special Feature Suffixes

A	Special body only — body pattern alterations not required. Flanges on forged valves not normally supplied with flanges. On socket end forged steel valves the inlet and outlet ends are different.
B	Venturi pattern body.
C	Locking devices consisting of padlock and chain.
CD	Locking devices, indicator type.
DD	Equalizer external.
DDI	Equalizer internal.
E	Permanent drain, hole in disk or groove in disk face.
F	Special trim material: used to designate special disk material, special stem material, or inconel spring in check valves.
FF	Special yoke bushing material, such as Austenitic Nodular Iron.
G	Bypasses on all types of cast steel valves
H	Spur gear operation.
HH	Bevel gear operation.
HHL	Valveless bevel gear actuator but with actuator mounting equipment.
J	Any unclassified special.
K	Throttle disk or skirted disk.
L	Impactor operated. Used now only to indicate impactor handwheel or handle on valves not regularly furnished with impactor.
LD	Impactorgear or Impactdrive.
M	Motor actuated.
ML	Valve less actuator but with motor actuator mounting equipment.

MM	Cylinder/diaphragm actuated. Either hydraulic or pneumatic.
MML	Valve less cylinder/diaphragm actuator but with actuator mounting equipment.
N	Body drilled and tapped or socketed for drains, with or without nipple, with or without drain valves.
P	Non-standard packing of all types.
PL	Plastic lined.
Q	Non-standard bonnet gaskets or gasket plating.
R	Special lapping and honing and gas testing (recommended for valves on high pressure gas service).
S	Smooth finish on contact faces of end flanges
T	Critical service requiring special testing and/or NDE.
UF	Unfinished ends
W	Stellited seat and disk. Suffix not used for valves that are cataloged as having stellited seat and disk as standard.
X	Ring joint facing on body end flanges.
Y	All welding ends either socket or butt. Suffix not used for valves where figure number designates welding ends as standard, such as Fig. 36224 and 66228 for example.
T1	ASME Section III Class 1 compliance.
T2	ASME Section III Class 2 compliance.
T3	ASME Section III Class 3 compliance.
T4	ASME Section III compliance without "N" stamp.
T5	Nuclear safety related-10CFR21 invoked.

Edward Description of Figure Number System

Example

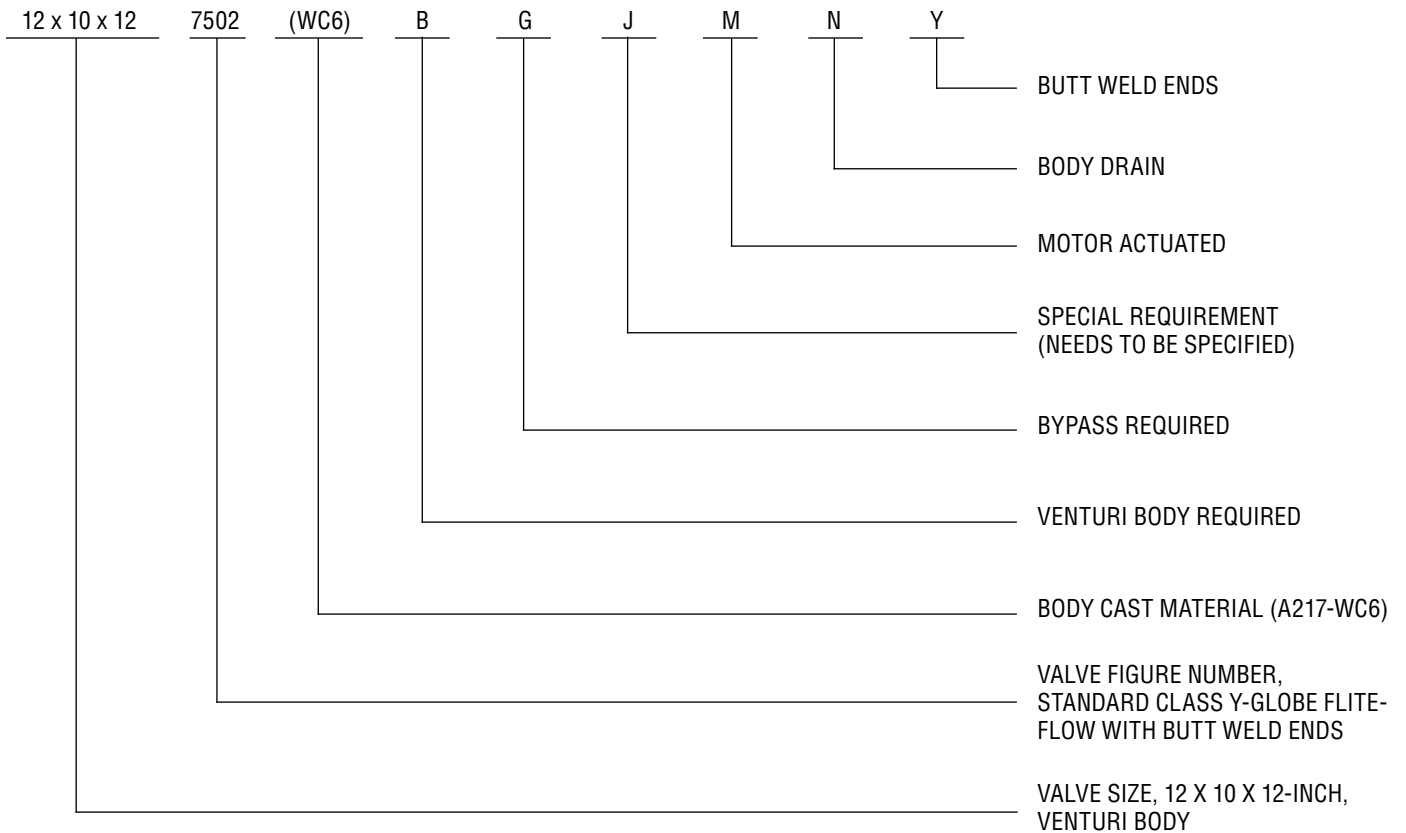

XX

1 Alpha Digit Prefix Indicates Design Revision if Applicable.

2 Alpha Digits Indicates Style of Pressure Combo Valve.

XXXXX

3-5 Digits Figure Number

(XXX)

3-4 Digits Body Material Designation

XXXXXXX

1 or more Digits As Required Suffixes (See List)

Unless otherwise specified when ordering Edward valves, the standard material of construction for Forged products is A105 Carbon Steel, and for Cast products is A216 Grade WCB Carbon Steel.

See the Edward Description of Figure Number System on page 8 for the letter suffixes used to indicate variations from standard construction, or special features (Ex. 618K, 7506 [WC6]Y, and 847 AH.)

When two or more suffixes follow a figure number a definite suffix sequence is to be used.

The sequence is:

- 1) Special material (if applicable)
- 2) All other applicable feature suffixes in alphabetical order. Except T1-T5 which are listed last.



High Performance for Critical Service

Temperatures that can exceed 1000°F. Pressures surpassing 10,000 psi. In critical service conditions, you can't take chances. You don't just meet standards, you exceed them. That's how Flowserve Edward forged and cast steel valves have become the specified choice for power plants, process facilities, and other high-temperature, high-pressure services.

Conservative Design

Flowserve Edward Valves takes a conservative approach to valve design. We meet all applicable codes and standards, but we go beyond that...with finite element stress analysis of critical areas and rigorous proof testing. Edward valves are built to take punishment!

And our extensive testing has also allowed us to develop extremely high flow efficiencies in all our valves.

You'll find other unique design advantages on our various product lines, such as our Equiwedge gate valves, with a two-piece wedge gate assembly that adjusts automatically to any angular distortion of the body seats. And many other design features, now considered industry "standards," started on the drawing boards at Flowserve.

Precision Manufacturing

Edward Valves also exceeds industry standards on the factory floor. Our forged valves are produced on a fully automated line, with CNC machining centers providing precise process control. And we maximize cast steel quality by producing our valve body castings using a directional solidifi-

cation process from patterns designed by our own technicians. This process assures high strength void free castings for uncompromised quality.

Even with the most advanced equipment, we feel our people make the real difference at Flowserve. Our production personnel have an average 20 years in the industry, and 15 years with Flowserve! This exceptional experience level allows us to achieve an extra degree of precision that can make a very real difference in the field.

Finally, it's our people, along with our procedures for quality assurance and lot-traceability, that have earned Flowserve Edward Valves the ASME N stamp, certifying our Raleigh, North Carolina manufacturing facility for nuclear-service valve production.

Lower Total Costs

Those tough standards have carried over into every valve we manufacture. Whether it is for nuclear service or not, we design and build our valves to last at least 40 years. That means not only are they tough, but they are designed with easy maintenance in mind.

Considering the cost of valve failure, Flowserve Edward Valves quality is clearly worth specifying. That's been true since 1904, when the first Edward valve was made.

Today, as industrial companies become increasingly aware that operating expenses are part of total cost, the choice becomes both more clear and more critical than ever.



Designed With an Eye on Your Bottom Line

In-house computer-aided design and finite-element method capabilities give our engineering staff powerful tools to develop reliable valves for critical service applications. CAD generated graphic models undergo FEM analysis to determine that stresses are within acceptable limits. Dynamic simulation of valve operation also helps assure reliability of Edward valve performance.

Prototyping is just as important, and rigorous proof testing is a mainstay of Edward valve design. Before we approve a valve for production, we put it through hundreds, even thousands, of cycles to demonstrate that performance and sealing integrity will be maintained in service. Transducers relay data from test assemblies to computers for further analysis.

Laboratory simulation of critical services includes a steam generator and superheater, designed for 2700 psi and 1050°F. This flexible system allows testing of prototype valves under both low pressure and high pressure conditions. In addition to prototype testing, this system has been used for applications such as: friction and wear tests of valve trim materials in hot water and steam environments; qualification tests of new or redesigned valves; and proof testing of new valve gaskets and valve stem packings.

Before we make the first production unit, that valve has already been through a rigorous program to assure long life, simple maintenance, and dependable performance for the lowest cost over the life of the valve. Again, people play important roles in design. The Flowserve product engineering department pools well over 200 years of valve experience.





Testing Beyond Code Requirements

At Flowserve Edward Valves, quality assurance starts with meeting code requirements. Valves are manufactured to ANSI B16.34 (Standard, Limited and Special Classes), including standards for:

- Minimum wall thickness of valve body.
- Body, bonnet and body-bonnet bolting to specified ASTM material standards.
- Hydrostatic shell testing at 1.5 times the 100°F rating of the valve.

From there, Flowserve Edward Valves goes on to exceed the code, with higher test standards and an additional battery of tests performed on every type of valve we make, using in-house test facilities and personnel to assure expert quality control. Edward Valves' quality assurance program includes:

Non-Destructive Examination

- All NDE personnel are qualified in accordance with ASNT-TC-1A guidelines.
- All castings are visually examined per MSS SP-55.
- The first five body castings from every pattern are 100% radiographed to verify casting quality.

Hydrostatic Testing

- The seat-leakage criteria — no visible leakage for forged steel and 2ml/hour/inch of nominal valve size for cast steel — are stricter than the allowed leakage rate of MSS SP-61, which is 10ml/hour/inch of nominal valve size.
- Seat-leakage test is performed at 110% of 100°F rating.

Statistical Process Control

Requirements are clearly stated and measurements are taken to determine conformance to those requirements. "Quality" equals conformance to requirements.



Welding

All personnel and procedures are qualified in accordance with ASME Boiler and Pressure Vessel Code, Section IX.

Additional Standard Tests for Specific Valves

Includes heavy-wall examination on large body castings.

We have only listed a few of the Flowserve Edward Valves standard tests that exceed industry requirements. Also, Edward Valves has the facilities and the expertise to meet additional quality-assurance standards, as required for the application.



A History of Firsts

Feature	Benefit
Body-guided disks on globe and angle valves	Minimize wear and ensure alignment for tight sealing.
Integral Stellite hardfaced seats in globe and angle valves	Permit compact design and resist erosion.
Hermetically sealed globe valves with seal-welded diaphragms	Prevent stem leakage in critical nuclear plant applications.
Equalizers for large check and stop-check valves	Ensure full lift at moderate flow rates, and prevent damage due to instability.
Compact pressure-seal bonnet joints	Eliminate massive bolted flanges on large, high-pressure valves.
Qualified stored-energy actuators	Allow quick-closing valves in safety-related nuclear plant applications.
Qualified valve-actuator combinations	Used in main steam and feed-water service throughout the world.
Stainless steel spacer rings on gate valves, fitted between wedge halves	Simplify service. Damaged valve seats can be restored to factory fit by in-line replacement with slightly thicker ring.
Unique two-piece, flexible wedges on gate valves	Automatically adjust to any angular distortion of body seats. Shape provides greater flexibility. Assure dependable sealing and prevent sticking.
Impactor handwheels and handles	Allow workers to generate several thousand foot-pounds of torque, thus ensuring tight shutoff of manually operated globe and angle valves.
Inclined-bonnet globe valves with streamlined flow passages	Minimize pressure drop due to flow.
Globe valves available with both vertical and inclined stems	Provide stem designs suited to any installation.
Live-loaded pressure energized PressurSeat® for globe valves	Globe valve design for high pressure drain and vent service.

Miscellaneous Technical Data

Edward Technical Articles

Number	Title
EVAWP3000	A Hermetically Sealed Valve for Nuclear Power Plant Service
EVAWP3001	Development of the Edward Equiwedge Gate Valve
EVAWP3003	Nuclear Containment of Postulated Feedwater Linebreak
EVAWP3004	Quick-Closing Isolation Valves – The Equiwedge Alternative
EVAWP3005	Valve Clamp Ring Stress Analysis
EVAWP3006	Univalve Evolution – Another Advance
EVAWP3007	The Type A Stored Energy Actuator – Development and Qualification
EVAWP3008	Model for Check Valve/Feedwater System Waterhammer Analysis
EVAWP3009	Minimizing Use of Cobalt and Strategic Materials in Valves
EVAWP3010	Asbestos-Free Stem Packing for High Temperature Valves
EVAWP3011	Quick-Closing Equiwedge Isolation Valves Global Qualification
EVAWP3012	Avoiding Aluminum Nitride Embrittlement in Steel Castings for Valve Components
EVAWP3013	Quick Closing Equiwedge Isolation Valves Global Qualification
EVAWP3014	Tests of Asbestos-Free Stem Packings for Valves for Elevated Temperature Service
EVAWP3015	Design Basis Qualification of Equiwedge Gate Valves for Safety-Related MOV Applications
EVAWP3016	Flow Performance, Stability and Sealability of Piston Lift and Tilting Disk Check Valves
EVAWP3017	Edward Cast Steel, Pressure-Seal Valves: Research and Development
EVAWP3018	Pressure Locking and Overpressurization of Double Seated Valves
EVAWP3019	Check and Stop-Check Valves for High Turndown Applications
EVAWP3020	PressurCombo
EVAWP3021	Hermavalve-A Zero Emissions Valve

Copies of the above Technical Articles are available upon request., or at www.flowserve.com

Sources for Additional Information

For further guidance on selection, shipping and storage, installation, operation, and maintenance of valves, readers are referred to the following documents:

MSS Valve User Guide
MSS SP-92

Available from:

Manufacturers Standardization Society of the Valve and Fittings Industry, Inc.
127 Park Street N.E.
Vienna, Virginia 22180

Aging and Service Wear of Check Valves Used in Engineering Safety-Feature Systems of Nuclear PowerPlants

Nureg/CR-4302

Ornl-6193/V1

Operating Experience and Failure Identification

Available from:

Superintendent of Documents
U.S. Government Printing Office
P.O. Box 37082
Washington, D.C. 20013-7982

And from:

National Technical Information Service
Springfield, Virginia 22161
EPRI Report No. NP 5479

Application Guidelines for Check Valves in Nuclear Power Plants

Available from:

Electric Power Research Institute
Research Reports Center
P.O. Box 50490
Palo Alto, CA 94303

Special Application Valves

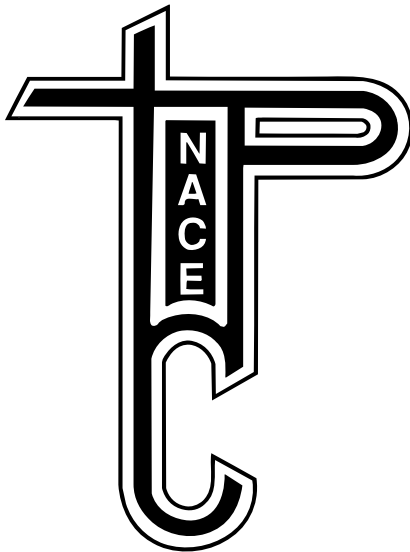

NACE VALVES

(NATIONAL ASSOCIATION OF CORROSION ENGINEERS)

Flowserve Edward Valves can provide valves constructed of materials that meet NACE standard MR-01-75 for sour service.

This standard entitled "Sulfide Stress Cracking Resistant Metallic Materials For Oil Field Equipment" covers material requirements for production, drilling, gathering and flow line equipment used in hydrogen sulfide bearing hydrocarbon service.

SPECIAL TRIM

Flowserve Edward Valves provides a standard valve trim that is compatible with the valve body chemistry, pressure class, operating temperature, and fluid. However, on application special trim materials to meet specific customer needs can be provided. Edward also can provide cobalt-free trim for nuclear applications.

- Cobalt Based Alloy 6
- Cobalt Based Alloy 21
- Iron Based Alloy
- Nickel Based Alloy
- Austenitic stainless steel
- Martensitic stainless steel
- Precipitation hardened stainless steel
- Super alloy steel

NON-STANDARD ENDS

Most Edward forged and cast steel valves can be provided with welding ends or flanged ends (small forged valves with threaded or socket weld ends also). On special order non-standard ends can be furnished to meet specific customer requirements. A partial list of available options include:

- GRAYLOC® hubs.
- Special flange facings.
- Non-standard end-to-end lengths — most Edward valves are manufactured to ANSI B16.10 criteria; however, non-standard ends are available as a special order.
- Venturi ends.
- Flanged by buttweld.
- Blank ends.
- Others as required.

Special Application Valves

Edward Throttle Valves

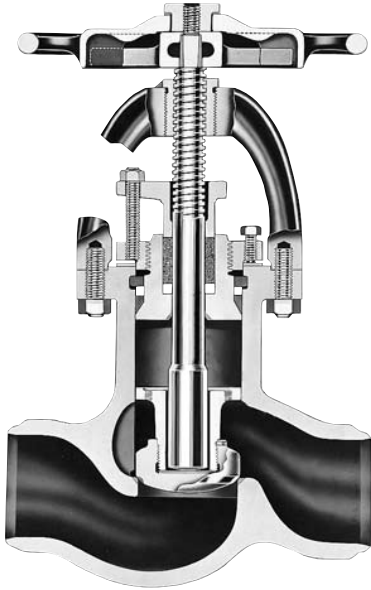

Edward standard cast steel valves with the body-guided feature have excellent ability to handle flow at high pressure differentials. However, for improved accuracy, cast globe and angle stop valves can be equipped with a special throttle disk. Disk shape provides good regulation over wide ranges of flow. When required, valves equipped with a throttle disk may also be ordered with a motor operator. Edward cast stop valves equipped with a throttle disk are identified by adding the suffix “K” to the standard valve figure number.

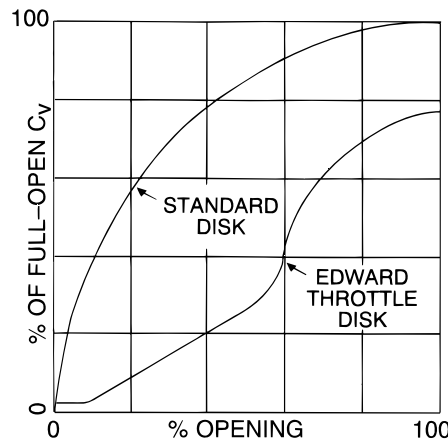

Comparison Curves Of Typical Standard Disk With Throttle Disk

The standard stop valve disk gives rapid increases in flow for each increment of lift at low lifts and small increases in flow at higher lifts. This is not desirable in many applications where the valve is used for controlling flow rate. The conical projection on the throttle disk gives straight line control at the lower lifts as long as it remains in the seat. Once the cone lifts entirely out of the seat it permits high capacity at high lifts with only moderate pressure drop penalty.

Edward Skirted Check Valves

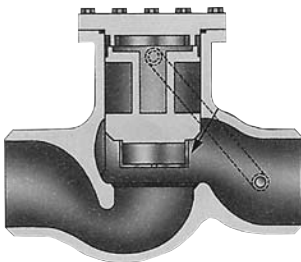

For check or stop-check applications with a broad range of flow conditions, a “skirted” disk, identified by adding the suffix “K” to the valve figure number may provide the required minimum lift at low flow while providing acceptable pressure drop at maximum flow. Specifically, the illustrated disk with a Mini-Skirt provides good low-flow performance while reducing C_v by only 10%. See the Flowserve Edward Valves Technical Article EVAWP3019 for assistance on high turndown applications.

Features and Description of Edward Flite-Flow® Globe Valves

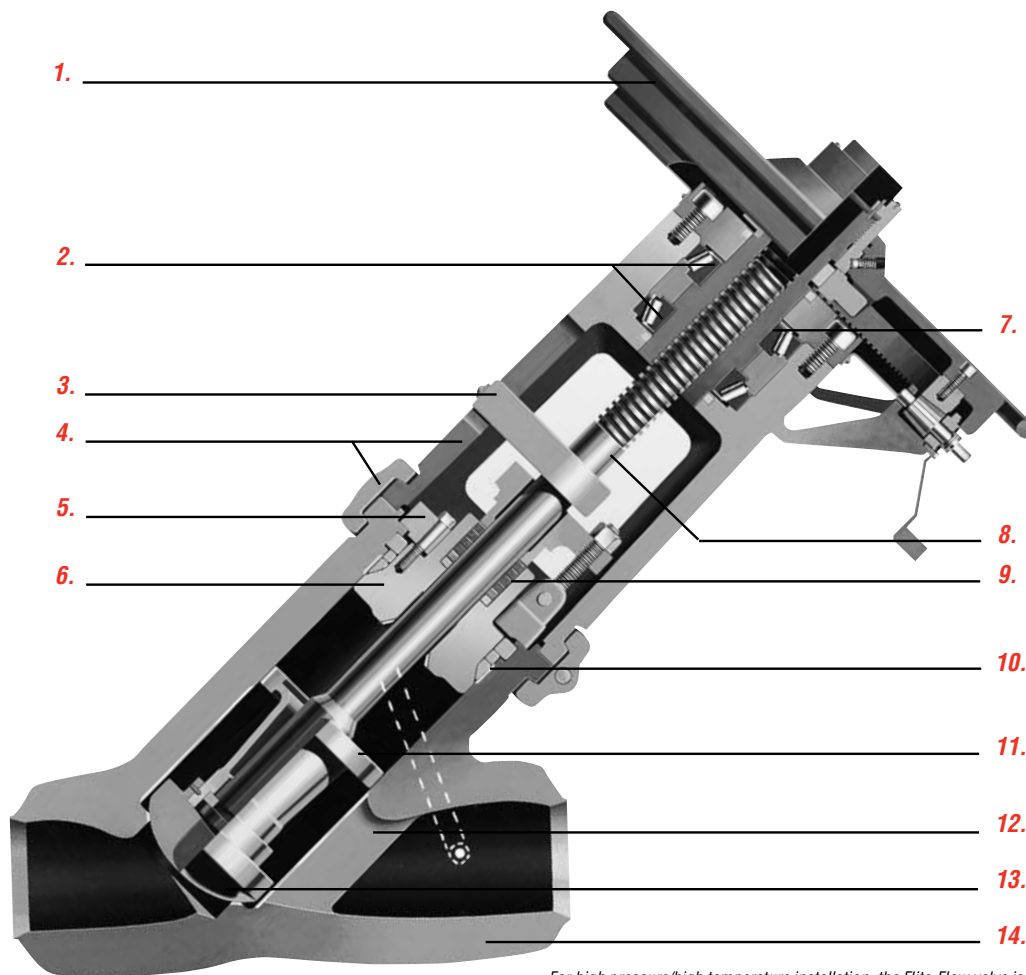

For high pressure/high temperature installation, the Flite-Flow valve is capable of handling millions of pounds per hour of fluid flow - without sacrificing low pressure drop or piping flexibility.

- 1. Impactor handwheel** - provides many times the closing force of an ordinary handwheel for positive seating. Impactogear, available on larger sizes, allows cycling by one man utilizing the air wrench adaptor.
- 2. Thrust bearings** minimize torque requirements and eliminate side loading due to out-of-position orientation. Smoother operation and longer valve life is possible.
- 3. Stem guide collar** - prevents stem rotation and provides valve position indication.
- 4. Yoke/Yoke lock ring** - the yoke is designed for ready access to the packing chamber and the lock ring allows quick disassembly for maintenance.
- 5. Bonnet retainer** provides loading to effect a seal at the pressure seal gasket.
- 6. Bonnet** is precision machined, retains packing and provides an integral hardfaced stem backseat.
- 7. Yoke bushing material** has low coefficient of friction which substantially reduces torque and thread wear and eliminates galling.
- 8. Stem** has ACME threads, is machined to a fine finish and is heat treated for improved strength and hardness to resist wear.
- 9. Stem packing system** utilizes flexible graphite packing material with anti-extrusion rings for optimum sealability and life.
- 10. Composite Pressure seal gasket** is a preloaded, pressure energized design for long reliable service.
- 11. Disk piston** is body guided to eliminate misalignment, galling and stem bending.
- 12. Guide ribs** - hardfaced on Flite-Flow and some angle patterns, provide body guiding for disk/piston assemblies.
- 13. Integral hardsurfaced seats** both body and disk provide shutoff and long seat life.
- 14. Body** utilizes optimized flow passages to minimize flow direction changes and reduce pressure drop.

Parts Specification List for Globe Valves Stop, Stop-Check & Piston Lift Check

This is not a complete list. Construction and materials will vary between sizes and pressure classes and may be changed without notice. For a complete, accurate, and itemized description of a particular valve, contact your Flowserve Edward Valves sales representative.

Description ⁽¹⁾	ASTM No.	ASTM No.	ASTM No.	ASTM No.	ASTM No.	ASTM No.
Body/Bonnet*	A-216 Grade WCB	A-216 Grade WCC	A-217 Grade WC6	A-217 Grade WC9	A-217 Grade C12A	A-351 Grade CF8M
Disk	A-105 —	A-105 —	A-182 Grade F11	A-182 Grade F22	A-182 Grade F91	A-182 Grade F316
Body-Guided Disk Nut	A-216 Grade WCB	A-216 Grade WCB	A-217 Grade WC6	A-217 Grade WC9	A-217 Grade C12A	A-182 Grade F316
Stem	A-182 Grade F6a	A-182 Grade F6a	A-182 Grade F6a	A-565 Grade 616 HT	A-565 Grade 616 HT	A-638 Grade 660 T2
Yoke Bushing	B-148 Alloy 95400	B-148 Alloy 95400	B-148 Alloy 95400	B-148 Alloy 95400	B-148 Alloy 95400	B-148 Alloy 95400
Packing Rings	Flexible Graphite inner rings and suitable anti-extrusion rings.					
Junk Rings	A-108 Grade 1018-20 MnPO ₄ Plated	A-108 Grade 1018-20 MnPO ₄ Plated	A-108 Grade 1018-20 MnPO ₄ Plated	A-108 Grade 1018-20 MnPO ₄ Plated	A-108 Grade 1018-20 MnPO ₄ Plated	A-182 Grade F316/Stellite I.D.
Pressure Seal Gasket	Composite Pressure Seal Gasket.					
Spacer Ring	A-668 Grade 4140 MnPO ₄ Plated	A-668 Grade 4140 MnPO ₄ Plated	A-668 Grade 4140 MnPO ₄ Plated	A-668 Grade 4140 MnPO ₄ Plated	A-668 Grade 4140 MnPO ₄ Plated	A-182 Grade F6 CL4
Gasket Retainer	A-182 Grade F6 CL4	SA-182 Grade F6 CL4	A-182 Grade F6 CL4	A-565 Grade 616 HT	A-565 Grade 616 HT	A-638 Grade 660 T2
Bonnet Retainer	A-216 Grade WCB	A-216 Grade WCB	A-216 Grade WCB	A-216 Grade WCB	A-216 Grade WCB	A-216 Grade WCB
Bonnet Retainer Studs	A-193 Grade B7	A-193 Grade B7	A-193 Grade B7	A-193 Grade B7	A-193 Grade B7	A-193 Grade B7
Bonnet Retainer Nuts	A-194 Grade 2H	A-194 Grade 2H	A-194 Grade 2H	A-194 Grade 2H	A-194 Grade 2H	A-194 Grade 2H
Gland	A-148 Grade 90-60	A-148 Grade 90-60	A-148 Grade 90-60	A-148 Grade 90-60	A-148 Grade 90-60	A-148 Grade 90-60/Chrome Plated
Eye Bolt	A-193 Grade B7/Cad. Plated	A-193 Grade B7/Cad. Plated	A-193 Grade B7/Cad. Plated	A-193 Grade B7/Cad. Plated	A-193 Grade B7/Cad. Plated	A-193 Grade B7/Cad. Plated
Eye Bolt Nuts	A-194 Grade 2H/Cad. Plated	A-194 Grade 2H/Cad. Plated	A-194 Grade 2H/Cad. Plated	A-194 Grade 2H/Cad. Plated	A-194 Grade 2H/Cad. Plated	A-194 Grade 2H/Cad. Plated
Eye Bolt Pins	A-182 Grade F6a Class 4	A-182 Grade F6a Class 4	A-182 Grade F6a Class 4	A-182 Grade F6a Class 4	A-182 Grade F6a Class 4	A-182 Grade F6a Class 4
Stem Guide Collar	A-515 Grade 70	A-515 Grade 70	A-515 Grade 70	A-515 Grade 70	A-515 Grade 70	A-515 Grade 70
Stem Guide Key	A-331 Grade 4140 HT	A-331 Grade 4140 HT	A-331 Grade 4140 HT	A-331 Grade 4140 HT	A-331 Grade 4140 HT	A-331 Grade 4140 HT
Yoke	A-216 Grade WCB	A-216 Grade WCB	A-216 Grade WCB	A-216 Grade WCB	A-216 Grade WCB	A-216 Grade WCB
Yoke Lock Ring	A-216 Grade WCB	A-216 Grade WCB	A-216 Grade WCB	A-216 Grade WCB	A-216 Grade WCB	A-216 Grade WCB
Yoke Lock Ring Studs	A-193 Grade B7	A-193 Grade B7	A-193 Grade B7	A-193 Grade B7	A-193 Grade B7	A-193 Grade B7
Yoke Lock Ring Nuts	A-194 Grade 2H	A-194 Grade 2H	A-194 Grade 2H	A-194 Grade 2H	A-194 Grade 2H	A-194 Grade 2H
Impactor Handwheel	A-126 Class A	A-126 Class A	A-126 Class A	A-126 Class A	A-126 Class A	A-126 Class A
Crossarm, Handwheel	A-536 Grade 65-45-12	A-536 Grade 65-45-12	A-536 Grade 65-45-12	A-536 Grade 65-45-12	A-536 Grade 65-45-12	A-536 Grade 65-45-12
Handwheel Bearing Nut	A-536 Grade 65-45-12	A-536 Grade 65-45-12	A-536 Grade 65-45-12	A-536 Grade 65-45-12	A-536 Grade 65-45-12	A-536 Grade 65-45-12
Stem Collar	A-182 Grade F6a	A-182 Grade F6a	A-182 Grade F6a	A-565 Grade 616 HT	A-565 Grade 616 HT	A-638 Grade 660 T2

Features and Description of Edward Stop-Check (Non-Return) Valves

Edward stop-check (non-return) valves offer the same tight-sealing performance as Edward stop valves, and at the same time, give check valve protection in the event of fluid back flow. Edward stop-check valves are commonly used to prevent back flow from a header fed from two or more sources when there is a loss of pressure in one of the sources — for example, the boiler outlet to a common header or at the feedwater heater outlets.

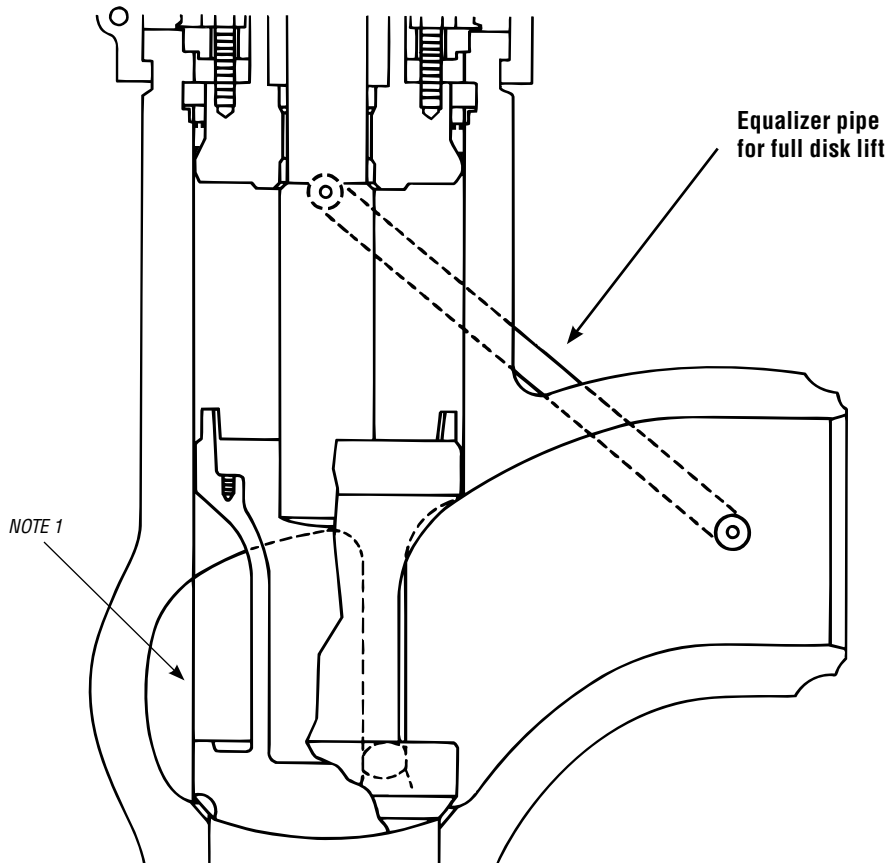

Flite-Flow®

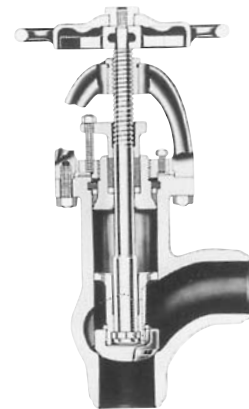

Angle

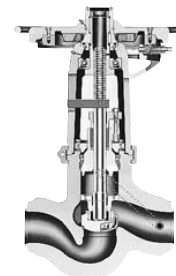

Globe

Equalizer

All Edward cast steel stop-check valves are equipped with an Equalizer pipe. Acting as an external pressure balancing pipeline, the Equalizer connects the zone above the disk with the lower pressure area in the valve outlet (see drawing above). This reduces pressure above the disk, and as a result, causes the higher pressure below the disk to raise the disk to full lift. The Equalizer helps reduce pressure drop and disk-piston movement and wear.

All other features are the same as those defined on page 17 for stop valves.

NOTE 1: Guide ribs are hardfaced on Flite-Flow and some angle pattern valves.



Elbow Down

Features and Description of Edward Check Valves

Over 75 years of valve field experience coupled with ongoing research and development programs have led to Flowserve Edward Valves reputation as a leader in supplying horizontal, angle, Flite-Flow and Elbow Down piston lift check valves.

These check valves all incorporate time proven design features such as: equalizers for full lift at lower flows; body guided disk-piston assemblies for seat alignment and stable operation; integral Stellite seating surfaces for long life and tight sealing; and streamlined flow shapes for low pressure drop. Flowserve Edward Valves maintains a reputation for the "Preferred" valve in critical high pressure high temperature applications.

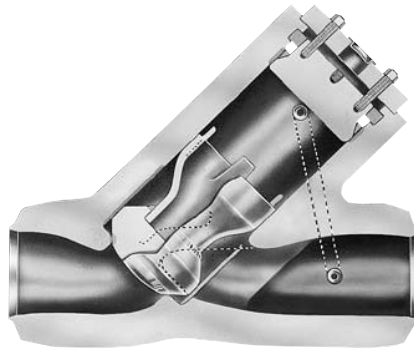

Flite-Flow®

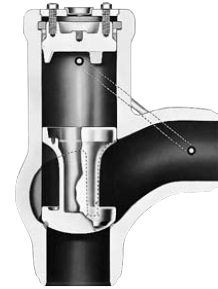

Angle

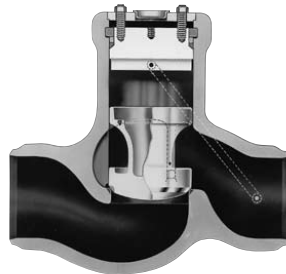

Globe

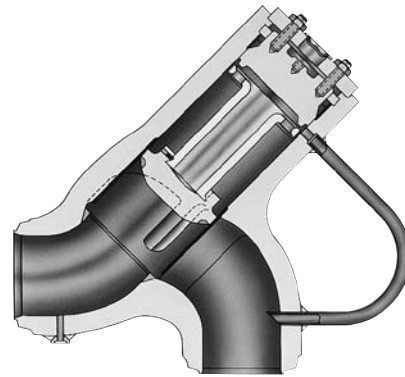

Elbow Down

Features and Descriptions of Edward One-Piece Tilting Disk Check Valves

The Edward tilting disk check valve is designed to close as quickly as possible. It minimizes loud, damaging slamming and vibration noises caused when high velocity reverse flow is allowed to build up before the completion of closing.

Quick Closing

Quick closing is achieved through a combination of several design construction features. The disk is dome shaped to avoid hesitation of disk motion or closing, common to conventional flat disks. For minimum pendulum period — an important factor in assuring quick closing — the disk pivot is located close to the center of gravity of the disk.

All disk surfaces are open to line fluid, so that no dashpot action can delay closing. The disk pivots on pin supports having chrome-plated bearings for minimum friction. Totally enclosed torsion springs in the pivot pins help speed the closing action, although the disk is counter-weighted sufficiently to close automatically without aid from the springs whether the valve is in a vertical or horizontal position. Since the springs are fully enclosed in the pins, they are not subject to possible erosive effects of line fluids and foreign matter cannot get in. There is no bolting in the flow stream.

Adjustable Hinge Pins

Available factory-installed or as a conversion kit, Edward Valves unique adjustable hinge pin replaces the usual concentric hinge pins with double offset eccentric hinge pins, making core alignment a matter of simply dialing in the fit.

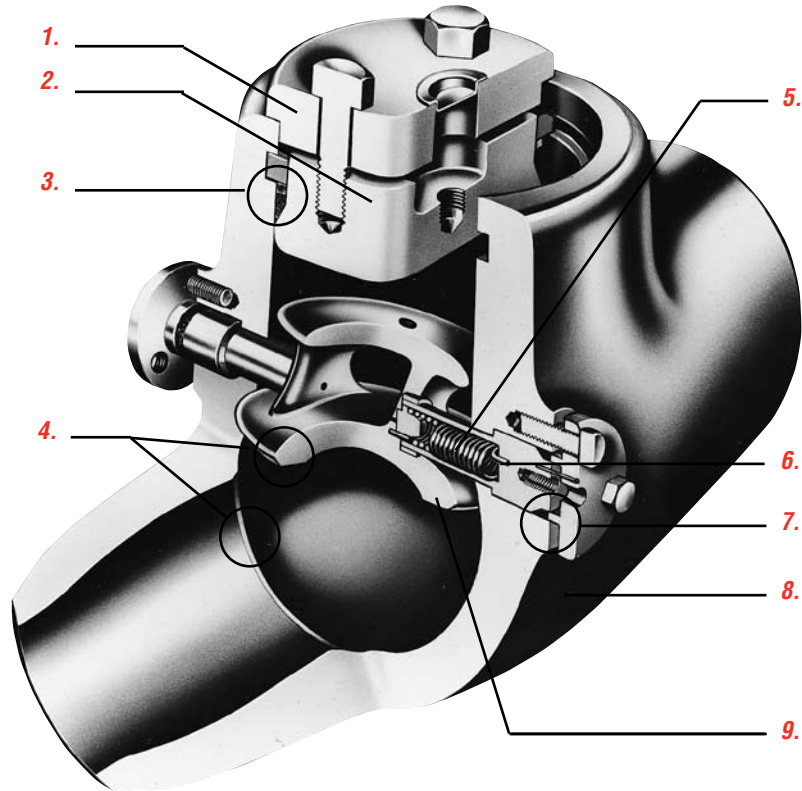

1. Cover retainer provides loading through the cover retainer and bolting to initiate a seal at the pressure seal gasket.
2. Cover is precision machined to retain pressure integrity and critical gasket seating surfaces.
3. Composite pressure seal gasket is a pre-loaded pressure energized flexible graphite composite for long reliable service.
4. Integral hardsurfaced seats, both body and disk, provide positive shutoff and long seat life.
5. Springs ensure quick closing of the disk by providing a positive seating force to speed closing.
6. Hinge pin provides a disk pivot point close to its center of gravity for fast response to flow reversals which minimizes water hammer effects.
7. Hinge pin gasket is spiral wound, coated steel, or flexible graphite for long reliable service.
8. Body features a straight thru compact design for low pressure drop.
9. Disk assembly is dome shaped and counterweighted for fast response to flow reversals.



Parts Specification List for Edward One-Piece Tilting Disk Check

This is not a complete list. Construction and materials will vary between sizes and pressure classes and may be changed without notice. For a complete, accurate, and itemized description of a particular valve, contact your Flowserve Edward Valves sales representative.

Description ⁽¹⁾	ASTM No.	ASTM No.	ASTM No.	ASTM No.	ASTM No.	ASTM No.
Body Cover*	A-216 Grade WCB	A-216 Grade WCC	A-217 Grade WC6	A-217 Grade WC9	A-217 Grade C12A	A-351 Grade CF8M
Disk††	A-105 —	A-105 —	A-182 Grade F11	A-182 Grade F22	A-182 Grade F91	A-182 Grade F316
Pressure Seal Gasket*	Composite Pressure Seal Gasket					
Spacer Ring	A-668 Grade 4140 MnPO ₄ Plated	A-668 Grade 4140 MnPO ₄ Plated	A-668 Grade 4140 MnPO ₄ Plated	A-668 Grade 4140 MnPO ₄ Plated	A-668 Grade 4140 MnPO ₄ Plated	Grade 182 Grade F6 CL4
Gasket Retainer	A-182 Grade F6 CL4	A-182 Grade F6 CL4	A-182 Grade F6 CL4	A-565 Grade 616 HT	A-565 Grade 616 HT	A-638 Grade 660 T2
Cover Retainer	A-216 Grade WCB	A-216 Grade WCB	A-216 Grade WCB	A-216 Grade WCB	A-216 Grade WCB	A-216 Grade WCB
Cover Retainer Capscrews or Studs	A-193 Grade B7	A-193 Grade B7	A-193 Grade B7	A-193 Grade B7	A-193 Grade B7	A-193 Grade B7
Cover Retainer Nuts	A-194 Grade 2H	A-194 Grade 2H	A-194 Grade 2H	A-194 Grade 2H	A-194 Grade 2H	A-194 Grade 2H
Hinge Pin Gasket Size 2½, 3, 4	Spiral Wound Gasket (Asb. Free)	Spiral Wound Gasket (Asb. Free)	Spiral Wound Gasket (Asb. Free)	Spiral Wound Gasket (Asb. Free)	Spiral Wound Gasket (Asb. Free)	Spiral Wound Gasket (Asb. Free)
Hinge Pin Gasket Size 6 & Larger	Graphite Gasket					
Hinge Pin	A-182 Grade F6aCL4	A-182 Grade F6aCL4	A-182 Grade F6aCL4	A-565 Grade 616 HT	A-565 Grade 616 HT	A-638 Grade 660 Type 2
Hinge Pin Bolts	A-193 Grade B7	A-193 Grade B7	A-193 Grade B16	A-193 Grade B16	A-453 Grade 660B	A-453 Grade 660B
Hinge Pin Retainer	A-105 —	A-105 —	A-182 Grade F11	A-182 Grade F22	A-182 Grade F91	A-182 Grade F316
Hinge Pin Springs†	A-313	A-313	A-313	A-313	A-313	A-313

*Other material grades available on application.

**All ANSI Class 600 valves utilize an asbestos-free spiral wound bonnet gasket.

†Hinge Pin Torsion Springs required in size 6 and larger valves only.

††Sizes 2½, 3 and 4, Pressure Classes 900, 1500 and 2500 – disk material is A732-GR21

Features and Description of Edward Equiwedge® Gate Valves

For detailed description of the two-piece flexible wedge see page 25.

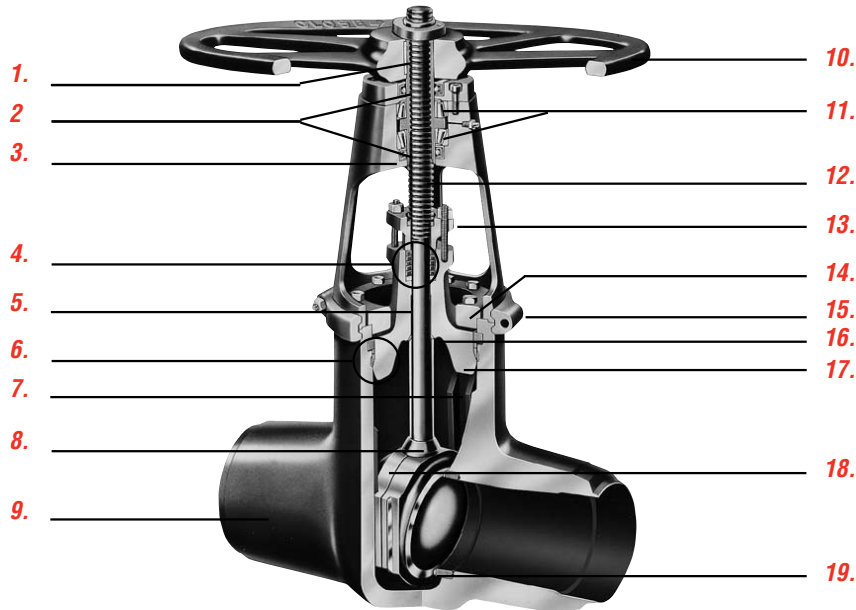

1. **Yoke bushing** – material has low coefficient of friction which substantially reduces torque and thread wear and eliminates galling.
2. **Weather/Grease seals** – are provided to protect against environmental conditions.
3. **Yoke** – the yoke is designed for ready access to the packing chamber.
4. **Packing and junk ring** – utilizes flexible graphite packing material with anti-extrusion rings for optimum sealability and life.
5. **Extended bonnet design** – further separates the packing chamber from fluid flow area for longer packing life. Also provides accessible area for leakoff connections if required.
6. **Composite pressure seal gasket** – preloaded, pressure energized design, for long reliable service.
7. **Body guiding system** – holds the wedge halves together and absorbs thrust loads due to line flow. Integral hardfaced guide system components reduce friction and prevent galling for longer valve life.
8. **Conical stem backseat** – Cone-on-cone design provides a reliable sealing geometry that operates over many valve cycles without leakage.
9. **Body** – rugged cast steel body provides maximum flow efficiency. Information on alternate materials can be obtained through your Flowserve representative.
10. **Handwheel** – spoke design provides more efficient transfer of load with minimum weight.
11. **Tapered roller bearings** – on larger valves, tapered roller bearings reduce torque, carry the stem thrust and provide additional radial support for side loads imposed by hand-wheel or power actuator. Smaller size valves have needle roller bearings.
12. **Stem** – has ACME threads, is machined to a fine finish and is heat treated for improved strength and hardness to resist wear.
13. **Packing gland** – made of alloy steel, and retained against the stuffing box pressure by an easy-to-maintain stud and heavy hex nut assembly.
14. **Bonnet retaining ring** – assures an effective, tight seal by pulling the bonnet and gasket together at the pressure seal.
15. **Yoke lock ring** – permits easier field maintenance of upper structure without disturbing pressure containing parts. Valves in smaller sizes utilize a wishbone yoke design. Class 600 valves utilize a bolted pressure seal bonnet.
16. **Bonnet backseat** – especially hard faced to assure long-term sealability.
17. **Hemispherical-type bonnet** – reduces valve body height and provides weight savings. Hemispherical-type design results in better pressure distribution across the bonnet area.
18. **Two-piece wedge assembly** – allows each wedge half to flex and adjust independently to compensate for body distortions caused by thermal changes or pipe bending stresses. (see pg. 25)
19. **Welded-in seat ring with hardfaced seat** – assures better wear and longer valve life. Seat ring is welded into the valve body to prevent leakage.

Parts Specification List for Gate Valves

This is not a complete list. Construction and materials will vary between sizes and pressure classes and may be changed without notice. For a complete, accurate, and itemized description of a particular valve, contact your Flowserve Edward Valves sales representative.

Description	ASTM No.	ASTM No.	ASTM No.	ASTM No.	ASTM No.	ASTM No.
Body/Bonnet*	A-216 Grade WCB	A-216 Grade WCC	A-217 Grade WC6	A-217 Grade WC9	A-217 Grade C12A	A-351 Grade CF8M
Gate 2½-6	A-732 Grade 21	A-732 Grade 21	A-732 Grade 21	A-732 Grade 21	A-732 Grade 21	A-732 Grade 21
Gate 8 and up*	A-216 Grade WCB	A-216 Grade WCB	A-217 Grade WC6	A-217 Grade WC9	A-217 Grade C12A	A-351 Grade CF8M
Stem	A-182 Grade F6 CL4	A-182 Grade F6 CL4	A-182 Grade F6 CL4	A-565 Grade 616 HT	*** A-565 Grade 616 HT	A-638 Grade 660 T2
Yoke Bushing	B-148 Alloy 95400	B-148 Alloy 95400	B-148 Alloy 95400	B-148 Alloy 95400	B-148 Alloy 95400	B-148 Alloy 95400
Packing Rings	Flexible Graphite inner rings and suitable anti-extrusion rings.					
Junk Rings	AISI 1117 Cad. Plated	AISI 1117 Cad. Plated	AISI 1117 Cad. Plated	AISI 1117 Cad. Plated	AISI 1117 Cad. Plated	A-182 Grade F316/Stellite I.D.
Pressure Seal Gasket**	Composite Pressure Seal Gasket.					
Spacer Ring	— A-668 Grade 4140 MnPO ₄ Plated	— A-668 Grade 4140 MnPO ₄ Plated	— A-668 Grade 4140 MnPO ₄ Plated	— A-668 Grade 4140 MnPO ₄ Plated	— A-668 Grade 4140 MnPO ₄ Plated	— A-182 Grade F6 CL4
Gasket Retainer	A-182 Grade F6 CL4	A-182 Grade F6 CL4	A-182 Grade F6 CL4	A-565 Grade 616 HT	A-565 Grade 616 HT	A-638 Grade 660 T2
Bonnet Retainer	A-515 Grade 70	A-515 Grade 70	A-515 Grade 70	A-515 Grade 70	A-515 Grade 70	A-515 Grade 70
Bonnet Retainer Studs	A-193 Grade B7	A-193 Grade B7	A-193 Grade B7	A-193 Grade B7	A-193 Grade B7	A-193 Grade B7
Bonnet Retainer Nuts	A-194 Grade 2H	A-194 Grade 2H	A-194 Grade 2H	A-194 Grade 2H	A-194 Grade 2H	A-194 Grade 2H
Gland	A-148 Grade 90-60	A-148 Grade 90-60	A-148 Grade 90-60	A-148 Grade 90-60	A-148 Grade 90-60	A-148 Grade 90-60/ Chrome Plated
Gland Studs	A-193 Grade B7/Cad. Plated	A-193 Grade B7/Cad. Plated	A-193 Grade B7/Cad. Plated	A-193 Grade B7/Cad. Plated	A-193 Grade B7/Cad. Plated	A-193 Grade B7/Cad. Plated
Gland Nuts	A-194 Grade 2H/Cad. Plated	A-194 Grade 2H/Cad. Plated	A-194 Grade 2H/Cad. Plated	A-194 Grade 2H/Cad. Plated	A-194 Grade 2H/Cad. Plated	A-194 Grade 2H/Cad. Plated
Yoke	A-216 Grade WCB	A-216 Grade WCB	A-216 Grade WCB	A-216 Grade WCB	A-216 Grade WCB	A-216 Grade WCB
Yoke Lock Ring	A-216 Grade WCB	A-216 Grade WCB	A-216 Grade WCB	A-216 Grade WCB	A-216 Grade WCB	A-216 Grade WCB
Yoke Lock Ring Studs	A-193 Grade B7	A-193 Grade B7	A-193 Grade B7	A-193 Grade B7	A-193 Grade B7	A-193 Grade B7
Yoke Lock Ring Nuts	A-194 Grade 2H	A-194 Grade 2H	A-194 Grade 2H	A-194 Grade 2H	A-194 Grade 2H	A-194 Grade 2H
Handwheel	A-126 Class A	A-126 Class A	A-126 Class A	A-126 Class A	A-126 Class A	A-126 Class A

* Hardfaced wedge guide rails and seating surfaces.

** Size 2½ thru 6, Class 600 & Size 2½ thru 4, Class 900 also available with bolted bonnet/flat gasket.

*** Use A-368 Grade 660 T2 for applications over 1100°F

Features and Description of Edward Equiwedge® Gate Valves

Unique Two-Piece Flexible Wedge

Wedging action provides tight seat sealing, even at low differential pressures. Wedge guiding by grooves in body minimizes seat wear and damage, since seating surfaces of wedge and body are in contact over less than 5% of total travel. Two separate flexible wedge halves are free to align with seats even when they are tilted or rotated due to thermal effects or piping loads. Resistance to thermal binding assures opening with a torque or load less than design closing load.

Wedge guide area and strength provides capability to support high differential pressures with valve partially open, so Equiwedge gate valves can be opened or closed under “blowdown” conditions. By-passes are not required if full differential is specified for actuator sizing.

Center Cavity Overpressurization

Some valve designs are capable of sealing simultaneously against a pressure differential between an internal cavity of the valve and the adjacent pipe in both directions. All double seated gate valves, including Equiwedge, are examples of such a design. In fact, seat joint integrity for these valves is tested in the factory by pressurizing the center cavity and simultaneously examining each seat. However, if a fluid is entrapped in such a valve while closed, and then subsequently heated, a dangerous rise in pressure can result thus leading to pressure boundary failure.

Both ASME B16.34 (Valves - Flanged, Threaded and Welding End), para 2.3.3 and ASME B31.1 (Pressure Piping Code), para 107.1(c), recognize this situation and require that the Purchaser shall provide means in design, installation and/or operation to assure that the pressure in the valve shall not exceed the rated pressure for the attained temperature. Therefore, if deemed necessary by the Purchaser, and so specified in the purchase order, Flowserve Edward Valves can provide an equalizer system (internal or external) that will relieve this trapped fluid to the upstream piping or a relief valve that will exhaust excessive pressure to some other specified area. It should be understood that an internal or external equalizer will change a basically by-directional gate valve to a

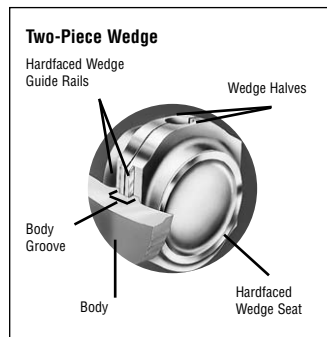

Figure 1

The outstanding design feature of the Equiwedge gate valve is unique two-piece wedge that permits maximum independence and flexibility for good sealability and freedom from sticking.

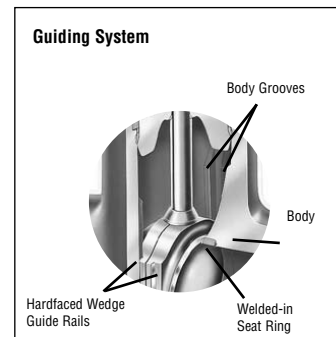

Figure 2

The body groove extends high in the body neck region so that in the open position the wedge assembly is both trapped and fully guided. Body grooves are hardfaced for critical service valves.

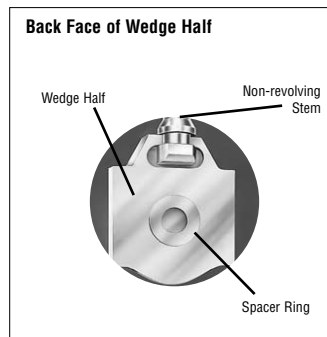

Figure 3

Wedge halves are separated the proper amount by a spacer ring which provides controlled deflection from stem loading. Use of a space and weight-saving “captured stem” (shown here and in Figure 4) is possible because of the two-piece wedge design.

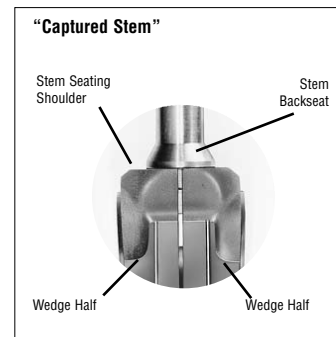

Figure 4

The Equiwedge two-piece wedge design allows the use of a space and weight saving “captured stem.”

design with fully effective seat sealing in only one direction. The equalizer bypasses the upstream seat and would allow leakage by that seat if the pressure should be reversed. The “downstream” seat would become the “upstream” seat with pressure reversed; the wedging action provided by stem load provides good upstream seat sealing at low to moderate pressures, but leakage could be excessive at high pressures.

Excessive pressure trapped in the center cavity of a gate valve can also produce “pressure

locking” — a condition that can make opening difficult or impossible. Either an internal or an external equalizer will prevent pressure locking. However, a relief valve may allow the center cavity pressure to be higher than either the upstream or downstream pressure, and this can allow pressure locking to occur. The Flowserve Edward Valves unique ACCEV (Automation Center Cavity Equalizing Valve) can alleviate this problem. Refer to page 98 for additional information.

Stop Valves

Class 300 740 PSI @ 100°F (51.1 BAR @ 38°C)

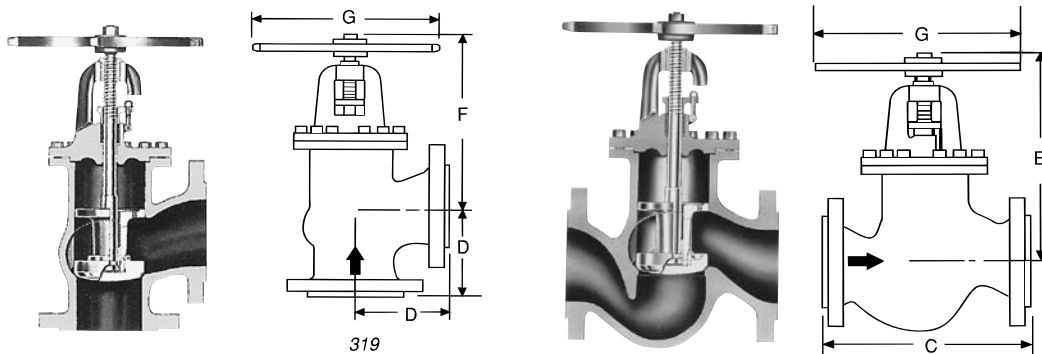

Standard Features

- Bodies and bonnets are cast steel (WCB & WC6).
- Bolted Bonnet, OS & Y.
- Globe & angle design.
- Integral Stellite seat, disk and backseat.
- Body-guided disk piston.
- 13% chromium stainless steel stem.
- Asbestos-free graphitic packing.
- Long Terne[#] steel gasket.

Pressure Class 300 (PN 50)

Fig. No.	Type	Ends	NPS (DN)
318	Globe	Flanged	3 (80) thru 12 (300)
318Y	Globe	Buttwelding	
319	Angle	Flanged	2½ (65) thru 12 (300)
319Y	Angle	Buttwelding	
329	Angle	Threaded	2½ (65)
329Y	Angle	Socket Welding	

Dimensions – Globe & Angle

Black numerals are in inches and pounds
Colored numerals are in millimeters and kilograms

Figure No. 318/318Y, 319/319Y, 329/329Y	NPS	2½	3	4	5	6	8	10	12
	DN	65	80	100	125	150	200	250	300
C - Face to Face, Globe (Flanged)•	—	12.5	14	15.76	17.5	22	24.5	28	
		318	356	400	445	559	622	711	
D - Center to Face, Angle (Flanged)•	5.75	6.25	7	7.88	8.75	11	12.25	14	
	146	159	178	200	222	279	310	356	
E - Center to Top, Globe (Open)	—	16.2	16.7	20.1	24.8	28.4	34.3	39.7	
		411	424	510	630	721	871	1008	
F - Center to Top, Angle (Open)	13.6	14.4	14.6	17.7	21.4	24.2	28.8	32.9	
	345	366	371	450	544	615	731	836	
G - Handwheel/Handle Diameter*	11	11.5	11.5	15	18	22	22	26	
	279	292	292	381	457	559	559	660	
Weight, Globe (Flanged)	—	100	193	226	370	525	895	1520	
		45	88	103	168	238	406	689	
Weight, Globe (Welding)	—	80	95	172	295	400	720	1270	
		36	43	78	134	181	327	576	
Weight, Angle (Flanged)	65	94	126	210	300	425	710	1250	
	29	43	57	95	136	193	322	561	
Weight, Angle (Welding)	55	70	85	152	225	325	530	970	
	25	32	39	69	102	147	240	440	

* Regular handwheel standard on all sizes except size 12 has an impactor handwheel and size 2½ has an impactor handle.

• Center to end or end to end dimensions for welding end valves same as center to contact face or contact face to contact face dimensions for flanged end valves.

26 # Long Terne Steel is a product coated by immersion in molten terne metal. Terne Metal is an alloy of lead and a small amount (about 3%) of tin.

Stop Valves

Class 300 740 PSI @ 100°F (51.1 BAR @ 38°C)

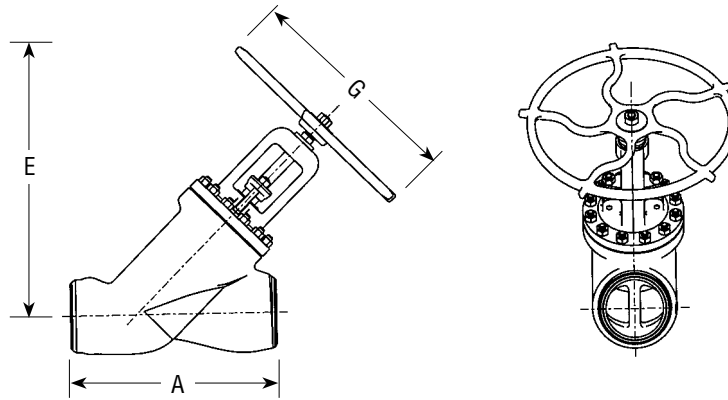

Standard Features

- Bodies and bonnets are cast steel (WCB, WC6).
- Bolted or OS & Y.
- Y-Pattern.
- Integral Stellite seat, disk and backseat.
- Body-guided disk piston.
- 13% chromium stainless steel stem.
- Asbestos-free graphitic packing.
- Gasket:
 - Size 2½ – 6 – asbestos-free, spiral wound.
 - All others – Long Terme[#] steel.

Pressure Class 300 (PN 50)*

Fig. No.	Type	Ends	NPS (DN)
1314	Flite-Flow	Flanged	2½ (65) thru 16 (400)
1314Y	Flite-Flow	Buttwelding	
1324	Flite-Flow	Threaded	2½ (65)
1324Y	Flite-Flow	Socket Welding	

* Size 3&4 Butt weld Valves are Class 400. See page 32.

Dimensions – Flite-Flow®

Black numerals are in inches and pounds
Colored numerals are in millimeters and kilograms

Figure No. 1314/1314Y 1324/1324Y	NPS	2 ½	3	4	6	8	10	12	14	16
	DN	65	80	100	150	200	250	300	350	400
A ₁ - End to End (Welding)		11.5	13	15.5	20	26.5	31	40	40	42
		292	330	394	508	673	787	1016	1016	1067
A ₂ - Face to Face (Flanged)		11.5	16	20.25	23.75	29	34.75	43	43.25	44
		292	406	514	603	737	883	1092	1099	1118
E - Center to Top (Open)		16	17.2	22	29	35	41	47.8	47.8	47.8
		406	437	559	737	889	1041	1213	1213	1213
G - Handwheel Diameter**		11	11.5	15	22	22	26	30	30	30
		279	292	381	559	559	660	762	762	762
Weight (Welding)		56	100	150	300	575	1030	1500	1525	1575
		25	45	68	136	261	468	682	693	716
Weight (Flanged)		70	130	200	380	700	1200	1750	1850	1950
		32	59	91	173	318	545	795	841	886

[#] Long Terme Steel is a product coated by immersion in molten terme metal. Terme Metal is an alloy of lead and a small amount (about 3%) of tin.

** Impactor handwheel standard on 10" and larger Flite-Flow Valves. Impactor handle standard on 2½" valve.

Stop-Check (Non-Return) Valves Class 300 740 PSI @ 100°F (51.1 BAR @ 38°C)

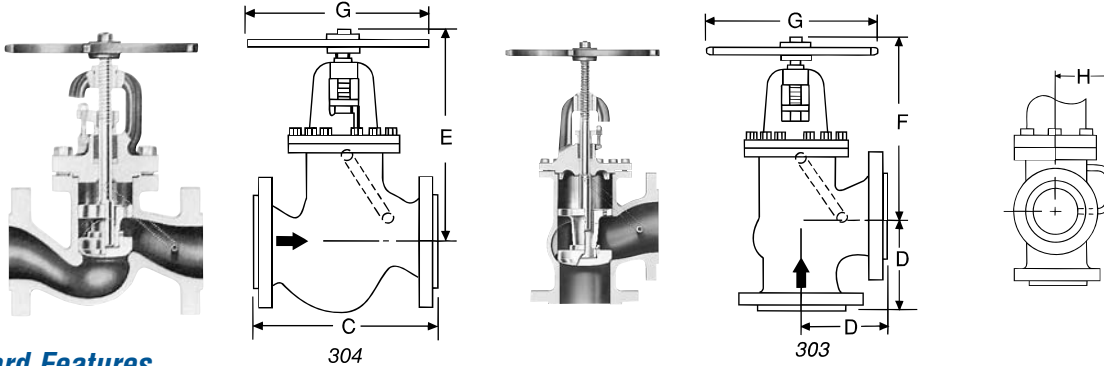

Standard Features

- Bodies and bonnets are cast steel (WCB & WC6).
- Bolted Bonnet, OS & Y.
- Globe & angle design.
- Integral Stellite seat, disk and backseat.
- Body-guided disk piston.
- 13% chromium stainless steel stem.
- Asbestos-free graphitic packing.
- Gasket:
 - Size 2½ – asbestos-free, spiral wound.
 - All others – Long Terme® steel.
- Equipped with equalizer.

Pressure Class 300 (PN 50)

Fig. No.	Type	Ends	NPS (DN)
304	Globe	Flanged	3 (80) thru 12 (300)
304Y	Globe	Buttwelding	
303	Angle	Flanged	2½ (65) thru 12 (300)
303Y	Angle	Buttwelding	

Dimensions – Globe & Angle

Black numerals are in inches and pounds
Colored numerals are in millimeters and kilograms

Figure No. 303/303Y, 304/304Y	NPS	2½	3	4	5	6	8	10	12
	DN	65	80	100	125	150	250	250	300
C - Face to Face, Globe•	—	—	12.5	14	15.76	17.5	22	24.5	28
	—	—	318	356	400	445	559	622	711
D - Center to Face, Angle•	5.75	6.25	7	7.88	8.75	11	12.25	14	—
	146	159	178	200	222	279	310	356	—
E - Center to Top, Globe	—	16.2	16.7	20.1	24.8	28.4	34.3	39.7	—
	—	—	411	424	510	630	721	871	1008
F - Center to Top, Angle	13.6	14.4	14.6	17.7	21.4	24.2	28.8	32.9	—
	345	366	371	450	544	615	731	836	—
G - Handwheel/Handle Diameter*	11	11.5	11.5	15	18	22	22	26	—
	279	292	292	381	457	559	559	660	—
H - Clearance for Equalizer	5.9	8.7	8.5	10	9.6	11	13.7	15	—
	150	221	216	254	244	279	348	381	—
Weight, Globe (Flanged)	—	100	110	230	370	525	920	1525	—
	—	—	45	50	104	168	238	417	692
Weight, Globe (Welding)	—	75	95	175	295	400	765	1365	—
	—	—	34	43	79	134	181	327	619
Weight, Angle (Flanged)	66	100	130	200	300	450	700	1250	—
	29	45	59	91	136	204	318	567	—
Weight, Angle (Welding)	51	70	90	152	215	325	560	970	—
	23	32	41	69	98	147	254	440	—

* Regular handwheel standard on all sizes except size 12 has an impactor handwheel and size 2½ has an impactor handle.

• Center to end or end to end dimensions for welding end valves same as center to contact face or contact face to contact face dimensions for flanged end valves.

28 # Long Terme Steel is a product coated by immersion in molten terme metal. Terme Metal is an alloy of lead and a small amount (about 3%) of tin.

Stop-Check (Non-Return) Valves Class 300 740 PSI @ 100°F (51.1 BAR @ 38°C)

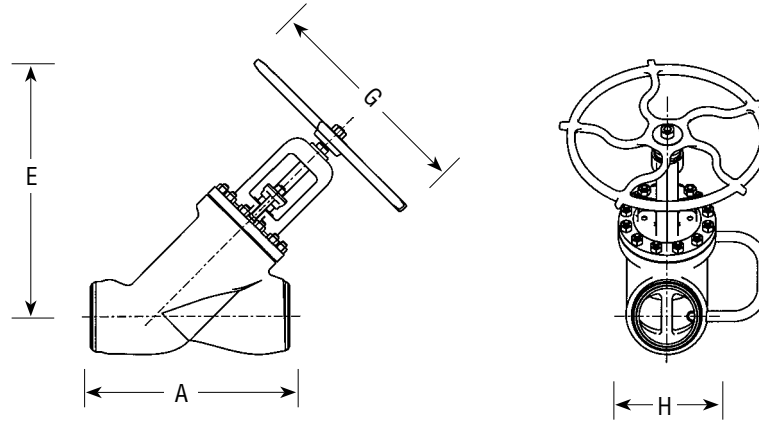

Standard Features

- Bodies and bonnets are cast steel (WCB, WC6).
- Bolted bonnet, OS & Y.
- Y-Pattern.
- Integral Stellite seat, disk and backseat.
- Body-guided disk piston.
- 13% chromium stainless steel stem.
- Asbestos-free graphitic packing.
- Gasket:
 - Size 2½ – 6 – asbestos-free, spiral wound.
 - All others – Long Terme[#] steel.
- Equipped with equalizer.

Pressure Class 300 (PN 50)*

Fig. No.	Type	Ends	NPS (DN)
1302	Flite-Flow	Flanged	2½ (65) thru 16 (400)
1302Y	Flite-Flow	Buttwelding	

Size 3&4 Buttweld End Valves are Class 400. See page 32.

Dimensions – Flite-Flow®

Black numerals are in inches and pounds
Colored numerals are in millimeters and kilograms

Figure No. 1302/1302Y	NPS	2½	3	4	6	8	10	12	14	16
	DN	65	80	100	150	200	250	300	350	400
A ₁ - End to End (Welding)		11.5	13	15.5	20	26.5	31	40	40	42
		292	330	394	508	673	787	1016	1016	1067
A ₂ - Face to Face (Flanged)		11.5	16	20.25	23.75	29	34.75	43	43.25	44
		292	406	514	603	737	885	1092	1099	1118
E - Center to Top (Open)		16	17.2	22	29	35	41	47.8	47.8	47.8
		406	437	559	737	889	1041	1213	1213	1213
G - Handwheel Diameter**		11	11.5	15	22	22	26	30	30	30
		279	292	381	559	559	660	762	762	762
Weight (Welding)		56	100	150	300	575	1030	1500	1525	1575
		25	45	68	136	261	468	682	693	716
Weight (Flanged)		70	130	200	380	700	1200	1750	1850	1950
		32	59	91	173	318	545	795	841	886

Long Terme Steel is a product coated by immersion in molten terme metal. Terme Metal is an alloy of lead and a small amount (about 3%) of tin.

** Impactor handwheel standard on 10 NPS & larger Flite-Flow Valves. 2½ NPS has impactor handle.

Check Valves

Class 300 740 PSI @ 100°F (51.1 BAR @ 38°C)

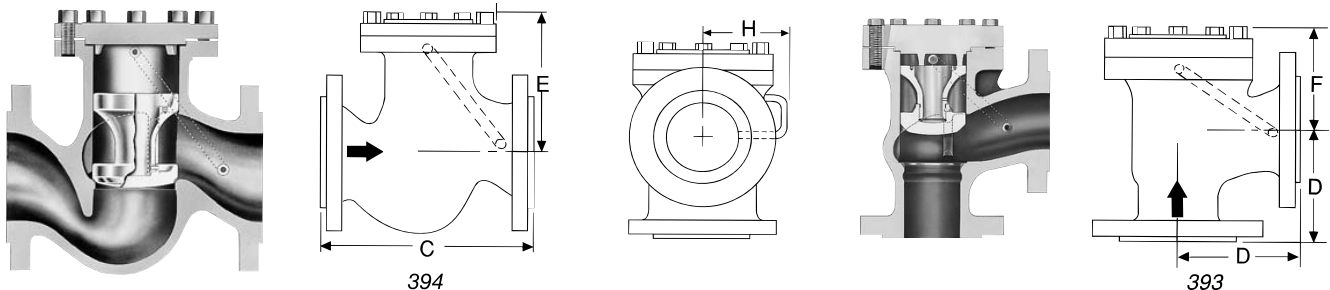

Standard Features

- Bodies and covers are cast steel (WCB & WC6).
- Bolted cover.
- Globe & angle design.
- Integral Stellite seat and disk.
- Body-guided disk piston.
- Gasket:
 - Size 2½ – asbestos-free, spiral wound.
 - All others – Long Terme[#] steel.
- Equipped with equalizer.

Pressure Class 300 (PN 50)

Fig. No.	Type	Ends	NPS (DN)
391	Angle	Threaded	2½ (65)
391Y	Angle	Socket Welding	
394	Globe	Flanged	3 (80) thru 12 (300)
394Y	Globe	Buttwelding	
393	Angle	Flanged	2½ (65) thru 12 (300)
393Y	Angle	Buttwelding	

Dimensions – Globe & Angle

Black numerals are in inches and pounds
Colored numerals are in millimeters and kilograms

Figure No. 391/391Y, 394/394Y, 393/393Y	NPS	2½	3	4	5	6	8	10	12
	DN	65	80	100	125	150	200	250	300
C - Face to Face, Globe•	—	—	12.5	14	15.76	17.5	22	24.5	28
	—	—	318	356	400	445	559	622	711
D - Center to Face, Angle•	5.75	6.25	7	7.88	8.75	11	12.25	14	—
	146	159	178	200	222	279	310	356	—
E - Center to Top, Globe	—	—	6.58	7.08	8.88	11.4	13.1	15.9	18.5
	—	—	167	180	226	290	333	405	470
F - Center to Top, Angle	3.88	4.82	4.96	6.44	8.04	8.9	10.5	11.7	—
	99	122	126	164	204	226	267	297	—
H - Clearance for Equalizer	5.9	8.7	8.5	10	9.6	11	13.7	15	—
	150	221	216	254	244	279	348	381	—
Weight, Globe (Flanged)	—	—	85	120	195	320	470	835	1280
	—	—	39	54	88	145	213	379	581
Weight, Globe (Welding)	—	—	60	85	141	250	350	620	1050
	—	—	27	39	64	113	159	281	476
Weight, Angle (Flanged)	49	78	108	175	250	375	600	980	—
	22	35	49	79	113	170	272	445	—
Weight, Angle (Welding)	35	53	70	121	260	250	430	820	—
	16	24	32	55	118	113	195	372	—

• Center to end or end to end dimensions for welding end valves same as center of contact face to contact face dimensions for flanged end valves.
Long Terme Steel is a product coated by immersion in molten terme metal. Terme Metal is an alloy of lead and a small amount (about 3%) of tin.

Check Valves Class 300 740 PSI @ 100°F (51.1 BAR @ 38°C)

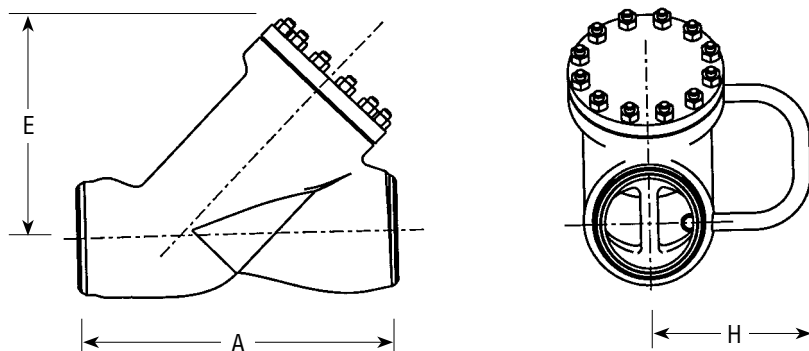

Standard Features

- Bodies and covers are cast steel (WCB & WC6).
- Bolted cover.
- Y-Pattern.
- Integral Stellite seat and disk.
- Body-guided disk piston.
- Gasket:
 - Size 2 1/2 - 6 - asbestos-free, spiral wound.
 - All others - Long Terme[#] steel.
- Equipped with equalizer.

Pressure Class 300 (PN 50)*

FIG. NO.	TYPE	ENDS	NPS (DN)
1392	Flite-Flow	Flanged	2½ (65)
1392Y	Flite-Flow	Buttwelding	16 (400)
1390	Flite-Flow	Threaded	2½ (65)
1390Y	Flite-Flow	Socket Welding	

* Size 3&4 Buttweld Valves are Class 400. See page 32.

Dimensions – Flite-Flow®

Black numerals are in inches and pounds
Colored numerals are in millimeters and kilograms

Figure No. 1392/1392Y	NPS	2½	3	4	6	8	10	12	14	16
	DN	65	80	100	150	200	250	300	350	400
A1- End to End (Welding)		11.5	13	15.5	20	26.5	31	40	40	42
		292	330	394	508	673	787	1016	1016	1067
A2- Face to Face (Flanged)		11.5	16	20.25	23.75	29	34.75	43	43.25	44
		292	406	514	603	737	883	1092	1099	1118
E - Center to Top/Check Valve		7	8	11	13.5	17	20	25.5	25.5	25.5
		178	203	279	343	432	508	648	648	648
Weight (Welding)		40	70	105	210	400	700	1050	1075	1125
		18	32	48	95	182	318	477	489	511
Weight (Flanged)		54	100	150	290	520	875	1300	1400	1500
		25	45	68	132	236	398	591	636	682

[#] Long Terme Steel is a product coated by immersion in molten terme metal. Terme Metal is an alloy of lead and a small amount (about 3%) of tin.

Stop Valves

Class 400 985 PSI @ 100°F (68.1 BAR @ 38°C)

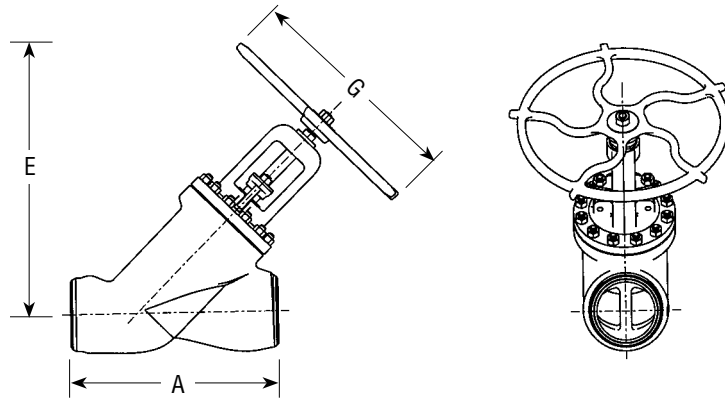

Standard Features

- Bodies and bonnets are cast steel (WCB, WC6).
- Bolted bonnet, OS & Y.
- Y-Pattern.
- Integral Stellite seat, disk and backseat.
- Body-guided disk piston.
- 13% chromium stainless steel stem.
- Asbestos-free graphitic packing.
- Asbestos-free spiral wound gasket.

Pressure Class 400 (PN 68)

Fig. No.	Type	Ends	NPS (DN)
1314Y	Flite-Flow	Buttwelding	3 (80) thru 4 (100)

Dimensions – Flite-Flow®

Black numerals are in inches and pounds
Colored numerals are in millimeters and kilograms

Figure No. 1314Y	NPS	3	4
	DN	80	100
A ₁ - End to End (Welding)		13	15.5
		356	394
E - Center to Top (Open)		16	22
		406	559
G - Handwheel Diameter		11.5	16
		292	406
Weight (Welding)		100	150
		45	68

Long Terme Steel is a product coated by immersion in molten terme metal. Terme Metal is an alloy of lead and a small amount (about 3%) of tin.

Stop-Check (Non-Return) Valves Class 400 985 PSI @ 100°F (68.1 BAR @ 38°C)

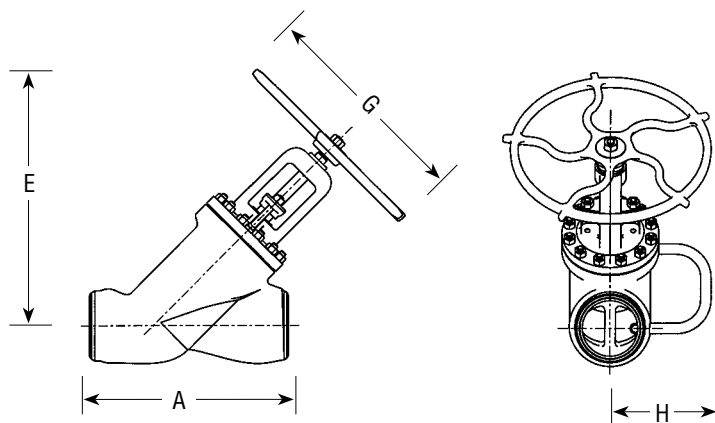

Standard Features

- Bodies and bonnets are cast steel (WCB, WC6).
- Bolted or pressure-seal bonnet, OS & Y.
- Y-Pattern.
- Integral Stellite seat, disk and backseat.
- Body-guided disk piston.
- 13% chromium stainless steel stem.
- Asbestos-free graphitic packing.
- Asbestos-free spiral wound gasket.
- Equipped with equalizer.

Pressure Class 400 (PN 68)

FIG. NO.	TYPE	ENDS	NPS (DN)
1302Y	Flite-Flow	Buttwelding	3 (80) thru 4 (100)

Dimensions – Flite-Flow®

Black numerals are in inches and pounds
Colored numerals are in millimeters and kilograms

Figure No. 1302Y	NPS	3	4
	DN	80	100
A - End to End (Welding)		13	15.5
		356	394
E - Center to Top (Open)		16	22
		406	559
G - Handwheel Diameter		11.5	16
		292	406
H - Equalizer Clearance		8.0	9.5
		203	241
Weight (Welding)		100	150
		45	68

Long Terme Steel is a product coated by immersion in molten terme metal. Terme Metal is an alloy of lead and a small amount (about 3%) of tin.

Check Valves

Class 400 985 PSI @ 100°F (68.1 BAR @ 38°C)

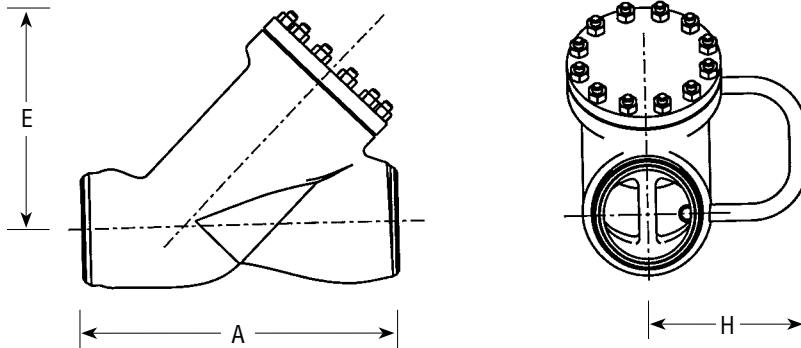

Standard Features

- Bodies and covers are cast steel (WCB, WC6).
- Bolted cover.
- Y-Pattern.
- Integral Stellite seat and disk.
- Body-guided disk piston.
- Asbestos-free spiral wound gasket.
- Equipped with equalizer.

Pressure Class 400 (PN 68)

Fig. No.	Type	Ends	NPS (DN)
1392Y	Flite-Flow	Buttwelding	3 (80) thru 4 (100)

Dimensions – Flite-Flow®

Black numerals are in inches and pounds
Colored numerals are in millimeters and kilograms

Figure No. 1392Y	NPS	3	4
	DN	80	100
A - End to End (Welding)		13	15.5
		356	394
E - Center to Top/Check Valve		8	11
		203	279
H - Equalizer Clearance		8.0	9.5
		203	241
Weight (Welding)		70	105
		32	48

Long Terme Steel is a product coated by immersion in molten terme metal. Terme Metal is an alloy of lead and a small amount (about 3%) of tin.

Stop Valves

Class 600 1480 PSI @ 100°F (102.1 BAR @ 38°C)

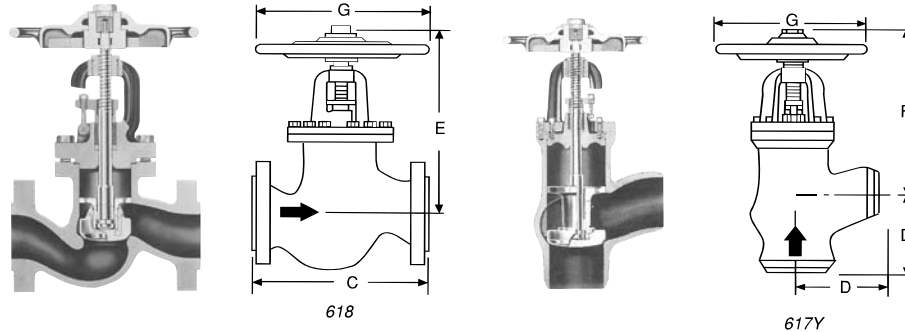

Standard Features

- Bodies and bonnets are cast steel (WCB, WC6, WC9, C12A).
- Bolted or pressure-seal bonnet, OS & Y.
- Globe or angle.
- Integral Stellite seat, disk and backseat.
- Body-guided disk piston.
- 13% chromium stainless steel stem.
- Asbestos-free graphitic packing.
- Long Terne[®] steel or composite pressure-seal gasket.

Pressure Class 600 (PN 110)

FIG. NO.		TYPE	ENDS	BONNET	NPS (DN)
STD CL	SPL CL				
616	—	Globe	Flanged	Bolted Pressure Seal	8 (200) thru 14 (350)
616Y	716Y	Globe	Buttwelding	Bolted Pressure Seal	
617	—	Angle	Flanged	Bolted Pressure Seal	8 (200) thru 14 (350), 24 (600), 28 (700) & 30 (750)
617Y	717Y	Angle	Buttwelding	Bolted Pressure-Seal	
618	—	Globe	Flanged	Bolted	2½ (65) thru 6 (150)
618Y	—	Globe	Buttwelding	Bolted	
619	—	Angle	Flanged	Bolted	
619Y	—	Angle	Buttwelding	Bolted	

Dimensions – Globe & Angle*

Black numerals are in inches and pounds
Colored numerals are in millimeters and kilograms

Figure No. 616/616Y, 617/617Y, 618/618Y, 619/619Y, 716Y, 717Y	NPS	2½	3	4	5	6	8	10	12	14
	DN	65	80	100	125	150	200	250	300	350
C - Face to Face, Globe •		13	14	17	20	22	26	31	33	35
		330	356	432	508	559	660	787	838	889
D - Center to Face, Angle •		6.5	7	8.5	10	11	13	15.5	16.5	17.5
		165	178	216	254	279	330	394	419	445
E - Center to Top, Globe		16.2	16.7	20.1	24.8	28.4	34.3	39.7	43.6	47
		411	424	511	630	721	871	1008	1107	1194
F - Center to Top, Angle		14.4	14.6	17.7	21.4	24.2	28.8	32.9	36.1	38.8
		366	371	450	544	615	731	836	917	986
G - Handwheel/Handle Diameter**		12	12	14	16	16	20	26	30	30
		305	305	356	406	406	508	660	762	762
Weight, Globe (Flanged)		110	135	245	425	525	900	1550	2200	2640
		50	61	111	193	238	408	703	998	1198
Weight, Globe (Welding)		90	110	180	315	400	750	1200	1850	2250
		41	50	82	143	181	340	544	839	1021
Weight, Angle (Flanged)		100	122	228	355	460	730	1230	1790	2120
		45	55	103	161	209	331	558	812	962
Weight, Angle (Welding)		100	125	170	245	350	540	950	1450	1760
		45	57	77	111	159	245	431	658	798

* Angle valves only, are also available in Sizes 24, 28, and 30. Dimensions available upon request.

** Impactor handwheel is standard on all size valves.

• Center to end or end to end dimensions for welding and valves same as center to contact face or contact face to contact face dimensions for flanged end valves.

Stop Valves

Class 600 1480 PSI @ 100°F (102.1 BAR @ 38°C)

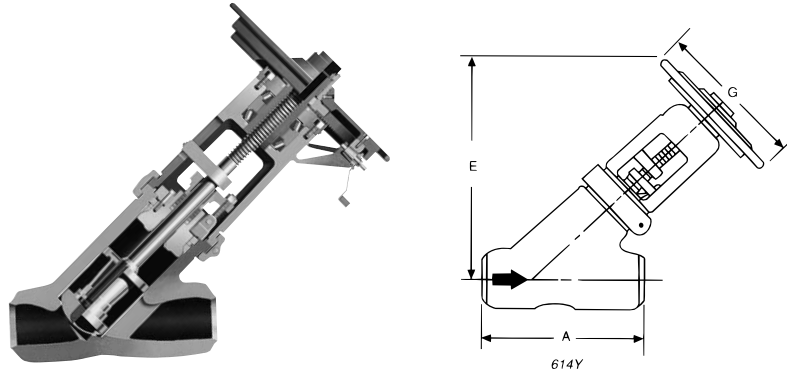

Standard Features

- Bodies and bonnets are cast steel (WCB, WCG, WC9, C12A).
- Pressure-seal bonnet, OS & Y.
- Y-Pattern.
- Integral Stellite seat, disk and backseat.
- Body-guided disk piston.
- 13% chromium stainless steel stem.
- Asbestos-free graphite packing.
- Spiral wound or composite pressure-seal gasket.

Pressure Class 600 (PN 110)*

Fig. No.		Type	Ends	Bonnet	NPS (DN)
STD CL	SPL CL				
614***	—	Flite-Flow	Flanged	*Pressure Seal	3 (80) thru 32 (800)
614Y	714Y	Flite-Flow	Buttwelding	*Pressure Seal	

* 3&4 Bolted bonnet with asbestos-free spiral wound gasket.
 * Size 3&4 Buttweld Valves are Class 700. See page 43.

Dimensions – Flite-Flow®

Black numerals are in inches and pounds
 Colored numerals are in millimeters and kilograms

Figure No. 614Y/714Y, 614***	NPS	3	4	6	8	10	12	14	16	20	24	26	28	32
	DN	80	100	150	200	250	300	250	400	500	600	650	700	800
A ₁ - End to End, (Welding)		13	15.5	20	26	31	38	38	41	60	66	70	81.5	90
		330	394	508	660	788	965	965	1041	1524	1676	1778	2070	2286
A ₂ - Face to Face, (Flanged)		16.75	21.25	29	33	39	43	43	52	*	*	*	*	*
		425	540	737	838	991	1092	1092	1321					
E - Center to Top, (Open)		17.5	21.5	28.5	34	42	49	49	74	71	*	*	*	*
		445	546	724	864	1067	1245	1245	1880	1803				
G - Handwheel Diameter		12	14	16	20	26	30	30	48	48	*	*	*	*
		305	356	406	508	660	762	762	1219	1219				
Weight, (Welding)		110	150	450	850	1400	2050	2050	5500	9200	*	*	*	*
		50	68	204	385	635	930	930	2495	4173				
Weight, (Flanged)		150	240	570	1000	1800	2450	2550	6500	*	*	*	*	*
		68	109	259	454	816	1111	1157	2948					

* Dimensions and information supplied upon request.
 ** Impactor handwheel standard on all Flite-Flow Valves.
 *** Flanged valves are available in sizes 3 through 16.

Stop Valves

Class 600 1480 PSI @ 100°F (102.1 BAR @ 38°C)

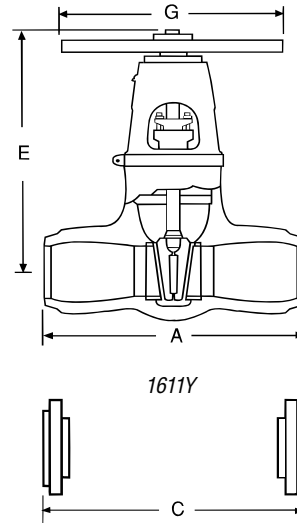

Standard Features

- Bodies and bonnets are cast steel (WCB, WCG, WC9, C12A).
- Pressure-seal bonnet OS & Y.
- Integral Stellite seats and backseat.
- Two-piece body-guided wedge.
- 13% chromium stainless steel stem.
- Asbestos-free graphitic packing.
- Composite pressure-seal gasket.
- Available in standard or venturi pattern.
- Yoke bushing thrust bearings.

Pressure Class 600 (PN 110)

Fig. No.		Type	Ends	Bonnet	NPS (DN)
STD CL	SPL CL				
1611*	—	Equiwedge Gate	Flanged	Pressure-Seal	2½ (65) thru 28 (700)
1611Y	1711Y	Equiwedge Gate	Buttwelding	Pressure-Seal	8 (200) thru 32 (800)
1611BY	1711BY	Venturi Pattern Equiwedge Gate	Buttwelding	Pressure-Seal	8 (200) thru 32 (800)

* Flanges to size 24 only.

Dimensions – Equiwedge Gate

Black numerals are in inches and pounds
Colored numerals are in millimeters and kilograms

Figure No. 1611/1611Y, 1711Y, A1611/A1611Y	NPS	2½	3	4	6	8	10	12	14
	DN	65	80	100	150	200	250	300	350
A - End to End (Welding)		10	10	12	18	23	28	32	35
		254	254	305	457	584	711	813	889
C - Face to Face (Flanged)		13	14	17	22	26	31	33	35
		330	356	432	559	660	787	838	889
E - Center to Top, (Open)		22.25	22.25	25.5	31.75	39.75	48	54	58.5
		565	565	648	806	1010	1219	1372	1486
G - Handwheel Diameter		14	14	14	24	24	30	30	36
		356	356	356	610	610	762	762	914
Weight (Welding)		81	81	175	372	667	1050	1623	2345
		37	37	79	169	303	476	738	1066

* E, G, and other dimensions and information supplied upon request.



Stop Valves Class 600 1480 PSI @ 100°F (102.1 BAR @ 38°C)

Dimensions – Equiwedge Gate (continued)

Black numerals are in inches and pounds
Colored numerals are in millimeters and kilograms

Figure No. 1611/1611Y, 1711Y	NPS	16	18	20	22	24	26	28
	DN	400	450	500	550	600	650	700
A - End to End (Welding)		39	43	47	51	55	57	61
		991	1092	1194	1295	1397	1448	1549
C - Face to Face (Flanged)		39	43	47	51	55	57	61
		991	1092	1194	1295	1397	1448	1549
E - Center to Top, (Open)		67	76	82.75	89	96	101	110.5
		1702	1930	2102	2261	2438	2565	2807
G - Handwheel Diameter		36	36	36	48	48	48	48
		914	914	914	1219	1219	1219	1219
Weight (Welding)		2950	3600	5000	5700	6500	8000	10,000
		1338	1633	2268	2585	2948	3628	4535

Dimensions – Equiwedge Gate Venturi Pattern

Black numerals are in inches and pounds
Colored numerals are in millimeters and kilograms

Figure No. 1611BY, 1711BY	NPS	8x6x8	10x8x10	12x10x12	14x12x14	16x14x16	18x16x18
	DN	200	250	300	350	400	450
A - End to End (Welding)		18	23	28	32	35	39
		457	584	711	813	889	991
E - Center to Top, (Open)		31.75	39.75	48	54	58.5	67
		806	1010	1219	1372	1486	1702
G - Handwheel Diameter		24	24	30	30	36	36
		610	610	762	762	914	914
Weight (Welding)		372	610	1114	1623	2345	2950
		169	277	506	738	1066	1338

Figure No. 1611BY, 1711BY	NPS	20x18x20	22x20x22	24x20x24	26x22x26	28x24x28	30x26x30	32x28x32
	DN	500	550	600	650	700	750	800
A - End to End (Welding)		43	47	47	51	55	57	61
		1092	1194	1194	1295	1397	1448	1549
E - Center to Top, (Open)		76	82.75	82.75	89	96	101	110.5
		1930	2102	2102	2261	2438	2565	2807
G - Handwheel Diameter		36	36	48	48	48	48	48
		914	914	1219	1219	1219	1219	1219
Weight (Welding)		3600	5000	5700	6500	7000	8500	10,500
		1633	2268	2585	2948	3175	3855	4762

Stop-Check (Non-Return) Valves

Class 600 1480 PSI @ 100°F (102.1 BAR @ 38°C)

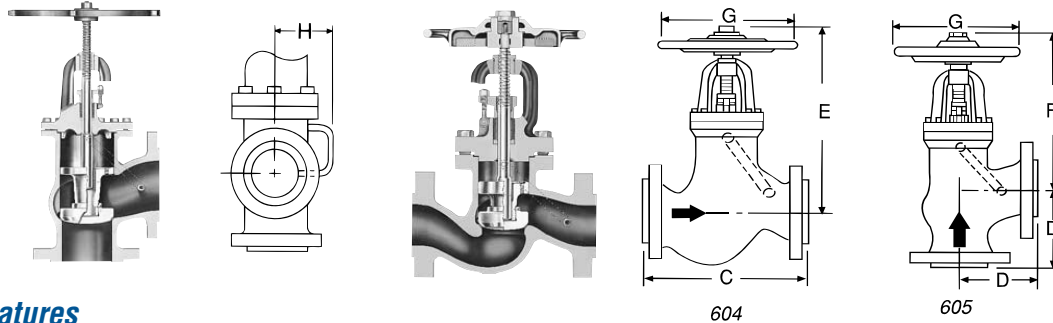

Standard Features

- Bodies and bonnets are cast steel (WCB, WC6, WC9 C12A).
- Bolted or pressure-seal bonnet OS & Y.
- Globe or angle.
- Integral Stellite seat, disk and backseat.
- Body-guided disk piston.
- 13% chromium stainless steel stem.
- Asbestos-free graphitic packing.
- Long terme[#] steel or composite pressure seal gasket.
- Equipped with equalizer.

Pressure Class 600 (PN 110)

FIG. NO.		TYPE	ENDS	BONNET	NPS (DN)
STD CL	SPL CL				
604	—	Globe	Flanged	Bolted	2½ (65) thru 6 (150)
604Y	—	Globe	Buttwelding	Bolted	
605	—	Angle	Flanged	Bolted	
605Y	—	Angle	Buttwelding	Bolted	
606	—	Globe	Flanged	Pressure-Seal	8 (200) thru 14 (350)
606Y	706Y	Globe	Buttwelding	Pressure-Seal	
607	—	Angle	Flanged	Pressure-Seal	8 (200) thru 14 (350), 24 (600), 28 (700) & 30 (750)
607Y	707Y	Angle	Buttwelding	Pressure-Seal	

Dimensions – Globe & Angle*

Black numerals are in inches and pounds
Colored numerals are in millimeters and kilograms

Figure No. 604/604Y, 605/605Y, 606/606Y, 607/607Y, 706Y, 707Y	NPS	2½	3	4	5	6	8	10	12	14
	DN	65	80	100	125	150	200	250	300	350
C - Face to Face, Globe**		13	14	17	20	22	26	31	33	35
		330	356	432	508	559	660	787	838	889
D - Center to Face, Angle**		6.5	7	8.5	10	11	13	15.5	16.5	17.5
		165	178	216	254	279	330	394	419	445
E - Center to Top, Globe		16.2	16.7	20.1	24.8	28.4	34.3	39.7	43.6	47
		411	424	511	630	721	871	1008	1107	1194
F - Center to Top, Angle		14.4	14.6	17.7	21.4	24.2	28.8	32.9	36.1	38.8
		366	371	450	544	615	731	836	917	986
G - Handwheel Diameter#		12	12	14	16	16	20	26	30	30
		305	305	356	406	406	508	660	762	762
H - Clearance for Equalizer		8.7	8.5	10	9.6	11	11.8	13	13.7	15.7
		221	216	254	244	279	300	330	348	399
Weight, Globe (Flanged)		110	135	220	425	540	960	1540	2200	2680
		50	61	112	193	245	435	699	998	1216
Weight, Globe (Welding)		84	110	185	335	410	750	1270	1850	2250
		38	50	84	152	186	340	596	839	1021
Weight, Angle (Flanged)		105	125	225	325	460	750	1200	1790	2150
		48	57	102	147	209	340	544	812	975
Weight, Angle (Welding)		80	90	168	245	350	560	950	1450	1760
		36	41	76	111	159	254	431	667	798

* Angle valves only, are also available in Sizes 24, 28, and 30. Dimensions available upon request.

** Center to end or end to end dimensions for welding and valves same as center to contact face or contact face to contact face dimensions for flanged end valves.

Impactor handwheel is standard on all size valves.

Stop-Check (Non-Return) Valves

Class 600 1480 PSI @ 100°F (102.1 BAR @ 38°C)

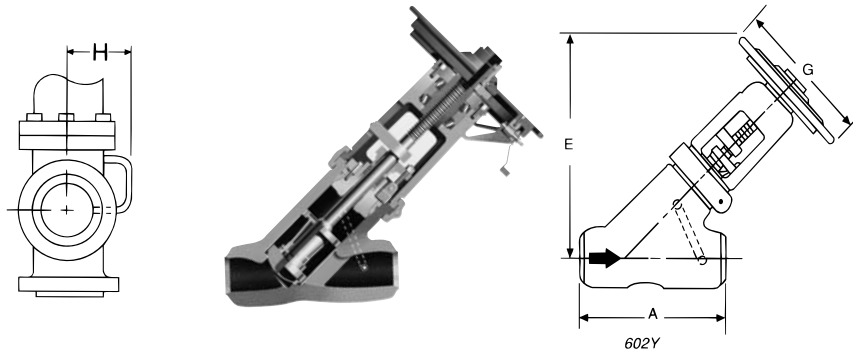

Standard Features

- Bodies and bonnets are cast steel (WCB, WC6, WC9, C12A).
- Bolted or pressure-seal bonnet, OS & Y.
- Y-Pattern.
- Integral Stellite seat, disk and backseat.
- Body-guided disk piston.
- 13% chromium stainless steel stem.
- Asbestos-free graphitic packing.
- Spiral wound or composite pressure seal gasket.
- Equipped with equalizer.

Pressure Class 600 (PN 110)*

Fig. No.		Type	Ends	Bonnet	NPS (DN)
STD CL	SPL CL				
***602	—	Flite-Flow	Flanged	Pressure-Seal*	3 (80) thru 32 (800)
602Y	702Y	Flite-Flow	Buttwelding	Pressure-Seal*	

* Size 3 & 4 - Bolted bonnet with asbestos-free spiral wound gasket.

* Size 3 & 4 Buttweld Valves are Class 700. See page 44.

Dimensions – Flite-Flow®

Black numerals are in inches and pounds
Colored numerals are in millimeters and kilograms

Figure No. 602Y/702Y, ***602	NPS	3	4	6	8	10	12	14	16	20	24	26	28	32
	DN	80	100	150	200	250	300	250	400	500	600	650	700	800
A1 - End to End, (Welding)		13	15.5	20	26	31	38	38	41	60	66	70	81.5	90
		330	394	508	660	787	965	965	1041	1524	1676	1778	2070	2286
A2 - Face to Face, (Flanged)		16.75	21.25	29	33	39	43	43	52	*	*	*	*	*
		425	540	737	838	991	1092	1092	1321					
E - Center to Top, (Open)		17.5	21.5	28.5	34	42	49	49	74	71	*	*	*	*
		445	546	724	864	1067	1245	1245	1880	1803				
G - Handwheel Diameter		12	14	16	20	26	30	30	48	48	*	*	*	*
		305	356	406	508	660	762	762	1219	1219				
H - Equalizer Clearance		7	9	10	12	13	14	14	22	24	*	*	*	*
		178	229	254	305	330	356	356	559	610				
Weight, (Welding)		110	150	450	850	1400	2050	2050	5500	9200	*	*	*	*
		50	68	204	385	635	930	930	2495	4173				
Weight, (Flanged)		150	240	570	1000	1800	2850	3100	6500	*	*	*	*	*
		68	109	259	454	816	1293	1406	2948					

* E, G, and other dimensions and information supplied upon request.

** Impactor handwheel standard on all Flite-Flow Valves.

*** Flanged valves available in sizes 3 thru 16.

Check Valves

Class 600 1480 PSI @ 100°F (102.1 BAR @ 38°C)

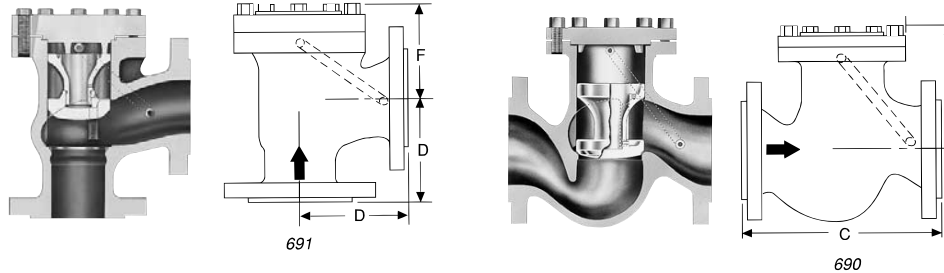

Standard Features

- Bodies and covers are cast steel (WCB, WC6, WC9, C12A).
- Bolted or pressure-seal cover.
- Y-Pattern, globe, angle, or tilting disk.
- Integral Stellite seats.
- Body-guided disk piston, globe, angle & Flite-Flow.
- Long Terme® steel or pressure-seal gasket.
- Equipped with equalizer, globe, angle & Flite-Flow.

Pressure Class 600 (PN 110)*

Fig. No.		Type	Ends	Bonnet	NPS (DN)
STD CL	SPL CL				
670Y	770Y	Tilting Disk	Buttwelding	Bolted	6 (150) thru 20 (500)
690	—	Globe	Flanged	Bolted	2½ (65) thru 6 (150)
690Y	—	Globe	Buttwelding	Bolted	
691	—	Angle	Flanged	Bolted	
691Y	—	Angle	Buttwelding	Bolted	
***692	—	Flite-Flow	Flanged	*Pressure Seal	3 (80) thru 32 (800)
692Y	792Y	Flite-Flow	Buttwelding	*Pressure Seal	
694	—	Globe	Flanged	Pressure Seal	8 (200) thru 14 (350)
694Y	794Y	Globe	Buttwelding	Pressure Seal	
695	—	Angle	Flanged	Pressure Seal	
695Y	795Y	Angle	Buttwelding	Pressure Seal	

* Size 3&4 - Bolted bonnet with asbestos-free spiral wound gasket.

* Size 3&4 Buttweld Flite-Flow Valves are Class 700. See page 45.

Dimensions – Globe & Angle

Black numerals are in inches and pounds
Colored numerals are in millimeters and kilograms

Figure No. 690/690Y, 691/691Y, 694/694Y, 695/695Y, 794Y, 795Y	NPS	2½	3	4	5	6	8	10	12	14
	DN	65	80	100	125	150	200	250	300	350
C - Face to Face, Globe (Flanged)•		13	14	17	20	22	26	31	33	35
		330	356	432	508	559	660	787	838	889
D - Center to Face, Angle (Flanged)•		6.5	7	8.5	10	11	13	15.5	16.5	17.5
		165	178	216	254	279	330	394	419	445
E - Center to Top, Globe		6.6	7.1	8.9	11.4	13.1	17.3	20.2	23.2	25.1
		168	180	226	290	333	439	513	589	638
F - Center to Top, Angle		4.8	5.0	6.4	8.0	8.9	11.9	13.4	15.5	16.6
		122	127	163	203	226	302	340	394	422
H - Clearance for Equalizer		8.7	8.5	10	9.6	11	11.8	13	13.7	15.7
		221	216	254	244	279	300	330	348	399
Weight, Globe (Flanged)		80	110	210	360	460	815	1290	1870	2320
		36	50	95	163	209	370	585	848	1052
Weight, Globe (Welding)		60	80	140	250	325	620	1040	1550	1930
		27	36	64	113	147	281	472	703	875
Weight, Angle (Flanged)		72	95	184	290	380	590	990	1490	1830
		33	43	84	132	172	268	449	676	830
Weight, Angle (Welding)		50	70	124	180	250	400	710	1170	1440
		23	32	56	82	113	181	322	531	653

• Center to end or end to end dimensions for welding end valves same as center to contact face or contact face to contact face dimensions for flanged end valves.

Long Terme Steel is a product coated by immersion in molten terme metal. Terme Metal is an alloy of lead and a small amount (about 3%) of tin.

*** Flanged valves available in sizes 3 to 16.

Check Valves

Class 600 1480 PSI @ 100°F (102.1 BAR @ 38°C)

Standard Features

- Bodies and covers are cast steel (WCB, WC6, WC9, C12A).
- Bolted or pressure-seal cover.
- Y-Pattern, globe, angle, or tilting disk.
- Integral Stellite seats.
- Body-guided disk piston, globe, angle & Flite-Flow.
- Gasket: Sizes 3 & 4 asbestos-free, spiral wound. All others: composite pressure seal.
- Equipped with equalizer, globe, angle & Flite-Flow.

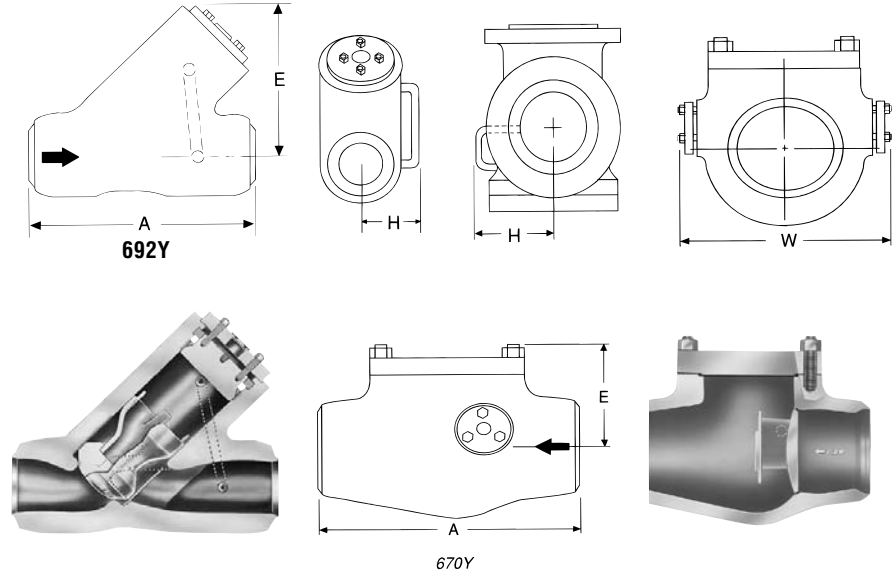

Dimensions – Flite-Flow

Black numerals are in inches and pounds
Colored numerals are in millimeters and kilograms

Figure No. 692Y/792Y ***692	NPS	3	4	6	8	10	12	14	16	20	24	26	28	32
	DN	80	100	150	200	250	300	250	400	500	600	650	700	800
A - End to End (Welding)		13	15.5	20	26	31	38	38	41	60	66	70	81.5	90
		330	394	508	660	787	965	965	1041	1524	1676	1778	2070	2286
A ₂ - Face to Face (Flanged)		16.75	21.5	29	33	39	43	43	52	*	*	*	*	*
		425	540	737	838	991	1092	1321	1321	*	*	*	-	-
E - Center to Top		7	11	15.75	17.75	21.25	25.25	25.25	31.5	36.0	*	*	*	*
		178	279	400	451	540	641	641	800	914				
H - Equalizer Clearance		7	9	10	12	13	14	14	22	24	*	*	*	*
		178	229	254	305	330	356	356	559	610	*	*	*	*
Weight (Welding)		80	125	375	575	1000	1450	1450	3300	*	*	*	*	*
		35	55	170	261	454	658	658	1497					
Weight (Flanged)		120	200	520	750	1250	1900	2150	4300	*	*	-	-	-
		54	90	236	340	567	862	975	1950					

* E, H and other dimensions and information supplied upon request.

*** Flanged valves available in sizes 3 thru 16.

Note: Size 3&4 Butt weld Class 600 Flite-Flow valves are Class 700. See page 45.

Dimensions – Tilting Disk

Figure No. 670Y/770Y	NPS	6	8	10	12	14	16	18	20
	DN	150	200	250	300	350	400	450	500
A - End to End (Welding)		19.5	22	28.5	34.5	34.5	43.25	48.25	53.5
		495	559	724	876	876	1099	1226	1359
E - Center to Top		9.5	10.5	13.5	15.5	15.5	20.5	22.5	23.75
		241	267	343	394	394	521	572	603
W - Width		15.25	17.5	21	25	25	32.25	34	38.5
		387	445	533	635	635	819	864	978
Weight (Welding)		300	500	950	1450	1550	2550	3550	5650
		136	225	428	653	698	1148	1598	2543

Stop Valves

Class 700 1725 PSI @ 100°F (119.1 BAR @ 38°C)

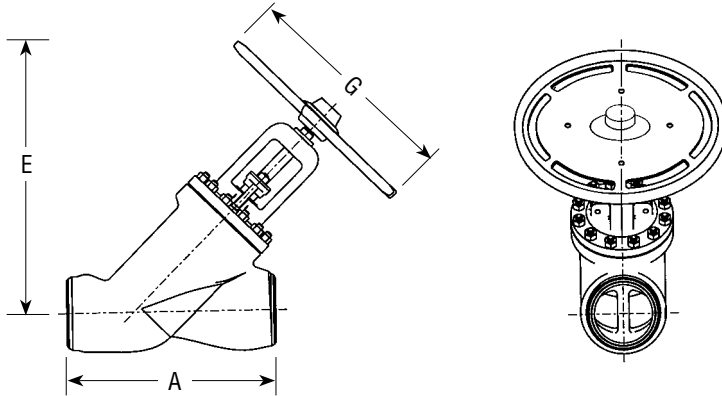

Standard Features

- Bodies and bonnets are cast steel (WCB, WC6, WC9, C12A).
- Bolted bonnet, OS & Y.
- Y-Pattern.
- Integral Stellite seat, disk and backseat.
- Body-guided disk piston.
- 13% chromium stainless steel stem.
- Asbestos-free graphitic packing.
- Asbestos-free spiral wound gasket.

Pressure Class 700 (PN 120)

Fig. No.		Type	Ends	Bonnet	NPS (DN)
STD CL	SPL CL				
614Y	714Y	Flite-Flow	Buttwelding	Bolted	3 (80) and 4 (100)

Dimensions – Flite-Flow®

Black numerals are in inches and pounds
Colored numerals are in millimeters and kilograms

Figure No. 614Y**, 714Y**	NPS	3	4
	DN	80	100
A - End to End (Welding)		13	15.5
		356	394
E - Center to Top, (Open)		16	21.5
		406	546
G - Handwheel Diameter		12	14
		279	356
Weight (Welding)		110	150
		50	68

** Impactor handwheel standard on all Flite-Flow Valves.

Stop-Check (Non-Return) Valves Class 700 1725 PSI @ 100°F (119.1 BAR @ 38°C)

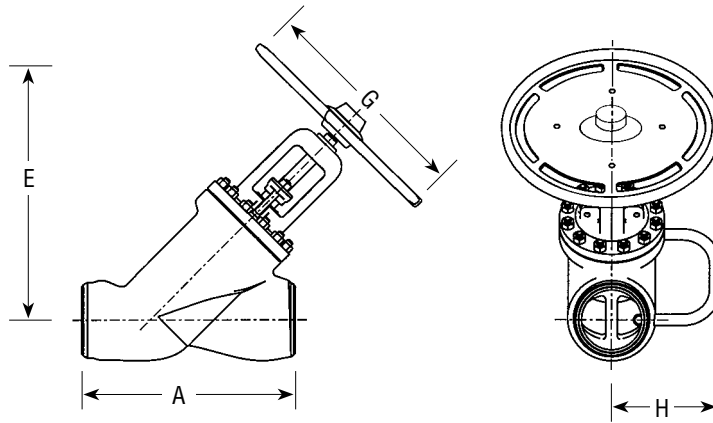

Standard Features

- Bodies and bonnets are cast steel (WCB, WC6, WC9, C12A).
- Bolted bonnet, OS & Y.
- Y-Pattern.
- Integral Stellite seat, disk and backseat.
- Body-guided disk piston.
- 13% chromium stainless steel stem.
- Asbestos-free graphitic packing.
- Asbestos-free spiral wound gasket.
- Equipped with equalizer.

Pressure Class 700 (PN 120)

Fig. No.		Type	Ends	Bonnet	NPS (DN)
STD CL	SPL CL				
602Y	702Y	Flite-Flow	Buttwelding	Bolted	3 (80) and 4 (100)

Dimensions – Flite-Flow®

Black numerals are in inches and pounds
Colored numerals are in millimeters and kilograms

Figure No. 602Y/702Y	NPS	3	4
	DN	80	100
A - End to End (Welding)		13	15.5
		356	394
E - Center to Top (Open)		16	21.5
		406	546
G - Handwheel Diameter**		12	14
		279	356
H - Equalizer Clearance		7	9
		178	229
Weight (Welding)		110	150
		50	68

** Impactor handwheel standard on Flite-Flow Valves.

Check Valves

Class 700 1725 PSI @ 100°F (119.1 BAR @ 38°C)

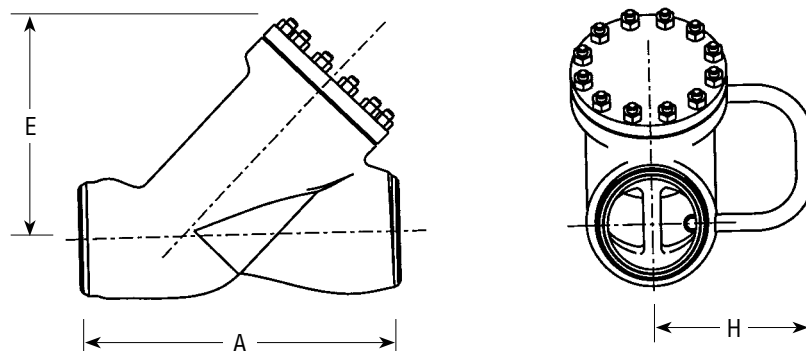

Standard Features

- Bodies and covers are cast steel (WCB, WC6, WC9, C12A).
- Bolted cover.
- Y-Pattern.
- Integral Stellite seat and disk.
- Body-guided disk piston.
- Asbestos-free spiral wound gasket.
- Equipped with equalizer.

Pressure Class 700 (PN 120)

Fig. No.		Type	Ends	Bonnet	NPS (DN)
STD CL	SPL CL				
692Y	792Y	Flite-Flow	Buttwelding	Bolted	3 (80) & 4 (100)

Dimensions – Flite-Flow®

Black numerals are in inches and pounds
Colored numerals are in millimeters and kilograms

Figure No. 692Y/792Y	NPS	3	4
	DN	80	100
A - End to End (Welding)		13	15.5
		356	394
E - Center to Top		8	11
		203	279
H - Equalizer Clearance		7	9
		178	229
Weight (Welding)		80	125
		35	55

Stop Valves

Class 900 2220 PSI @ 100°F (153.2 BAR @ 38°C)

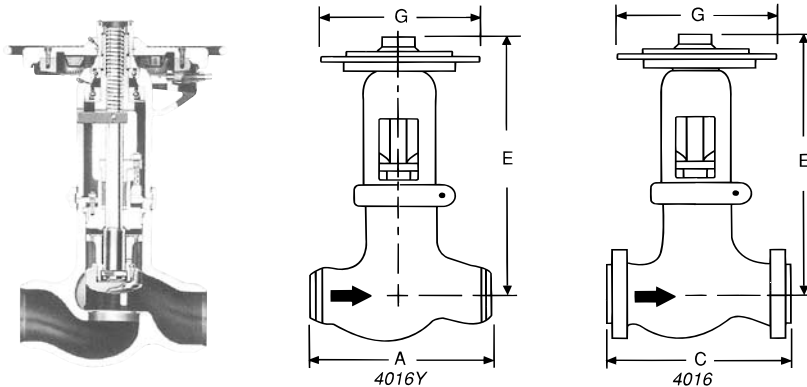

Standard Features

- Bodies and bonnets are cast steel (WCB, WC6, WC9, C12A, CF8M, or CF8C).
- Pressure-seal Bonnet, OS & Y.
- Y-Pattern, globe & angle design.
- Integral Stellite seat, disk and backseat.
- Body-guided disk piston.
- 13% chromium stainless steel stem.
- Asbestos-free graphitic packing.
- Yoke bushing thrust bearings size 5 and larger.

Pressure Class 900 (PN 150)*

Fig. No.		Type	Ends	NPS (DN)
STD CL	SPL CL			
4016	—	Globe	Flanged	3 (80) thru 14 (350)
4016Y	4316Y	Globe	Buttwelding	
4017	—	Angle	Flanged	3 (80) thru 24 (600)
4017Y	4317Y	Angle	Buttwelding	
4014	—	Flite-Flow	Flanged	3 (80) thru 16 (400)
4014Y	4314Y	Flite-Flow	Buttwelding*	

Size 3 & 4 Buttweld Flite-Flow Valves are class 1100 - see page 55.

Dimensions - Globe & Angle

Black numerals are in inches and pounds
Colored numerals are in millimeters and kilograms

Figure No. 4016/4016Y, 4017/4017Y, 4316Y, 4317Y	NPS	3	4	5	6	8	10	12	14
	DN	80	100	125	150	200	250	300	350
A - End to End (Welding)		15	18	22	24	29	33	38	40.5
		381	457	559	610	737	838	965	1029
B - Center to Face (Welding)		7.5	9	11	12	14.5	16.5	19	19
		190	229	279	305	368	419	483	483
C - Face to Face (Flanged)		15	18	22	24	29	33	38	40.5
		381	457	559	610	737	838	965	1029
D - Center to Face (Flanged)		7.5	9	11	12	14.5	16.5	19	21.75
		190	229	279	305	368	419	483	552
E - Center to Top, Globe (Open)		22.5	26.25	30.6	37	46	54.75	64.75	71.25
		572	667	777	940	1168	1391	1645	1810
F - Center to Top, Angle (Open)		20.4	23.75	28.25	34.25	43.4	49.25	60	60
		518	603	718	870	1102	1251	1524	1524
G - Handwheel Diameter*		16	16	20	20	28	28	36	36
		406	406	508	508	711	711	914	914
Weight, Globe (Flanged)		210	310	610	800	1570	2410	3700	4600
		95	141	277	363	712	1093	1665	2086
Weight, Globe (Welding)		175	235	500	620	1390	2300	3100	3850
		79	107	227	281	630	1043	1395	1746
Weight, Angle (Flanged)		206	284	540	710	1360	2103	3010	3060
		93	129	245	322	612	946	1365	1388
Weight, Angle (Welding)		150	210	410	552	1035	1690	2555	2580
		68	95	185	250	466	761	1159	1170

* Impactor handwheel is standard on all valves.

Stop Valves

Class 900 2220 PSI @ 100°F (153.2 BAR @ 38°C)

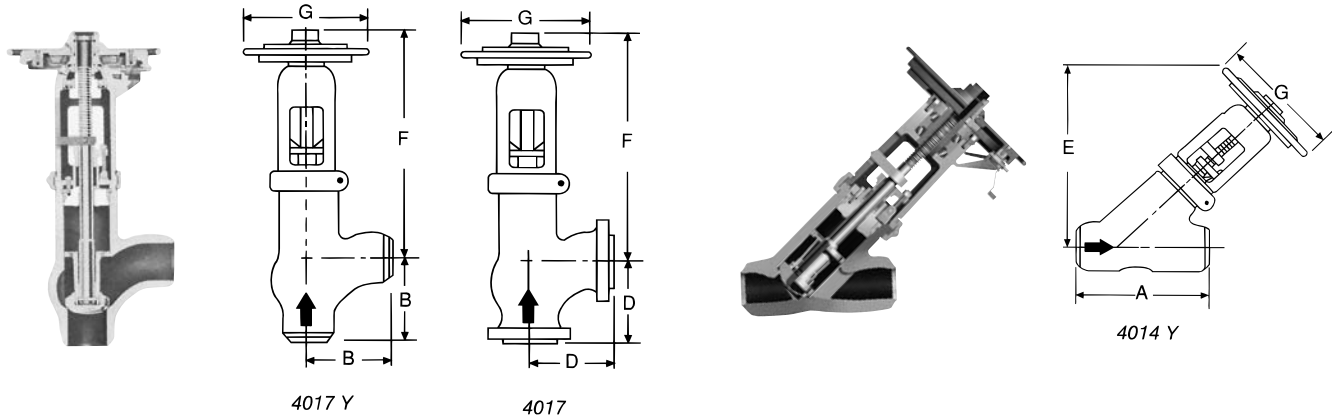

Dimensions - Angle

Black numerals are in inches and pounds
Colored numerals are in millimeters and kilograms

Figure No. 4017/4017Y, 4317Y	NPS	16	18	20	24
	DN	400	450	500	600
B - Center to End (Welding)		26	**	32.5	39
		660		825	991
F - Center to Top, Angle		78.5	**	95	102
		1994		2413	2591
G - Handwheel Diameter*		48	**	72	72
		1219		1829	1829
Weight, Angle (Welding)		4440	**	8150	13,750
		2014		3697	6237

** Size 18 angle - available upon request.

Dimensions - Flite-Flow®

Figure No. 4014/4014Y, 4314Y	NPS	3	4	6	8	10	12	14	16
	DN	80	100	150	200	250	300	350	400
A ₁ - End to End (Welding)		17	18.5	20	26	31	38	38	44.5
		432	479	508	660	787	965	965	1130
A ₂ - Face to Face (Flanged)		22.25	23.75	30	38	44	50	51	58
		565	603	762	965	1118	1270	1295	1473
E - Center to Top (Open)		20	25	35	44	51	60	60	73
		508	635	889	1118	1295	1524	1524	1854
G - Handwheel Diameter*		16	16	20	28	28	36	36	48
		406	406	508	711	711	914	914	1219
Weight (Welding)		190	275	550	1150	2100	3400	3400	5550
		86	125	249	522	953	1542	1542	2517
Weight (Flanged)		250	370	775	1550	2650	4150	4550	6950
		113	168	352	703	1202	1882	2064	3152

* Impactor handwheel is standard on all valves.

Note: Size 3&4 Butt-weld Class 900 Flite-Flow Valves are Class 1100. See page 55.

Stop Valves

Class 900 2220 PSI @ 100°F (153.2 BAR @ 38°C)

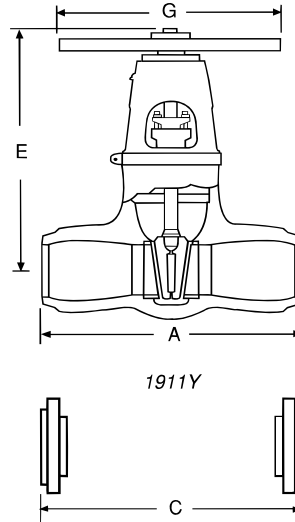

Standard Features

- Bodies and bonnets are cast steel (WCB, WC6, WC9, C12A, CF8M or CF8C).
- Pressure-seal bonnet, OS & Y.
- Integral Stellite seat, disk and backseat.
- Two-piece body-guided wedge.
- 13% chromium stainless steel stem.
- Asbestos-free graphitic packing.
- Available in standard or venturi pattern.
- Yoke bushing thrust bearings.
- Composite pressure seal gasket.

Pressure Class 900 (PN 150)

Fig. No.		Type	Ends	Bonnet	NPS (DN)
STD CL	SPL CL				
1911	—	Equiwedge Gate	Flanged*	Pressure-Seal	2½ (65) thru 28 (700)
1911Y	14311Y	Equiwedge Gate	Buttwelding	Pressure-Seal	
1911BY	14311BY	Venturi Pattern Equiwedge Gate	Buttwelding	Pressure-Seal	8 (200) thru 32 (800)

Dimensions – Equiwedge Gate

Black numerals are in inches and pounds
Colored numerals are in millimeters and kilograms

Figure No. 1911/1911Y, 14311Y	NPS	2½	3	4	6	8	10	12	14
	DN	65	80	100	150	200	250	300	350
A - End to End (Welding)		12	12	14	20	26	31	36	39
		305	305	356	508	660	787	914	991
C - Face to Face (Flanged)		16.5	15	18	24	29	33	38	40.5
		419	381	457	610	737	838	965	1029
E - Center to Top (Open)		21.25	21.25	24.5	33.5	40	46.75	54.5	59
		540	540	622	851	1016	1187	1384	1499
G - Handwheel Diameter		14	14	18	24	24	36	36	36
		356	356	457	610	610	914	914	914
Weight (Welding)		95	125	165	380	690	1523	2118	2805
		43	57	75	172	313	692	963	1275

Stop Valves

Class 900 2220 PSI @ 100°F (153.2 BAR @ 38°C)

Dimensions – Equiwedge Gate (continued)

Black numerals are in inches and pounds
Colored numerals are in millimeters and kilograms

Figure No. 1911/1911Y, 14311Y	NPS	16	18	20	22	24	26	28
	DN	400	450	500	550	600	650	700
A - End to End (Welding)		43	48	52	57	61	64	68
		1092	1291	1321	1448	1549	1626	1727
C - Face to Face (Flanged)		44.5	48	52	57	61	Available Upon Request	
		1130	1291	1321	1448	1549		
E - Center to Top (Open)		68	73.75	82	89.25	95	102	109
		1727	1873	2083	2267	2413	2591	2769
G - Handwheel Diameter		36	36	48	48	48	60	60
		914	914	1219	1219	1219	1524	1524
Weight (Welding)		4150	4300	5800	7500	9600	12,000	
		1882	1950	2631	3402	4355	5443	

Dimensions - Equiwedge Gate Venturi Pattern

Black numerals are in inches and pounds
Colored numerals are in millimeters and kilograms

Figure No. 1911BY, 14311BY	NPS	8x6x8	10x8x10	12x10x12	14x12x14	16x14x16	18x16x18
	DN	200	250	300	350	400	450
A - End to End (Welding)		20	26	31	36	39	43
		508	660	787	914	991	1092
E - Center to Top (Open)		33.5	40	46.75	54.5	59	68
		851	1016	1187	1384	1499	1727
G - Handwheel Diameter		24	24	36	36	36	36
		610	610	914	914	914	914
Weight (Welding)		530	891	1523	2118	2805	4150
		241	405	692	963	1275	1882

Figure No. 1911BY, 14311BY	NPS	20x18x20	22x20x22	24x20x24	26x22x26	28x24x28	30x26x30	32x28x32
	DN	500	550	600	650	700	750	800
A - End to End (Welding)		48	52	52	57	61	64	68
		1219	1321	1321	1448	1549	1626	1727
E - Center to Top (Open)		73.75	82	82	89.25	95	102	109
		1873	2083	2083	2267	2413	2591	2769
G - Handwheel Diameter		36	48	48	48	48	60	60
		914	1219	1219	1219	1219	1524	1524
Weight (Welding)		4500	6970	7200	8000	10,000	12,500	15,000
		2041	3162	3266	3629	4536	5670	6804

Stop-Check (Non-Return) Valves

Class 900 2220 PSI @ 100°F (153.2 BAR @ 38°C)

Standard Features

- Bodies and bonnets are cast steel (WCB, WC6, WC9, C12A, CF8M or CF8C).
- Pressure-seal Bonnet, OS & Y.
- Y-Pattern, globe & angle design.
- Integral Stellite seat, disk and backseat.
- Body-guided disk piston.
- 13% chromium stainless steel stem.
- Asbestos-free graphitic packing.
- Equipped with equalizer.
- Yoke bushing thrust bearings.

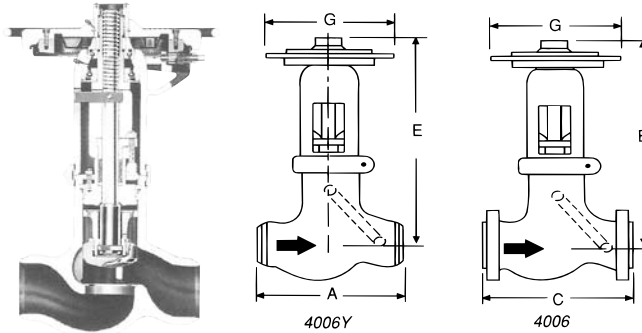

Pressure Class 900 (PN 150)*

FIG. NO.		TYPE	ENDS	NPS (DN)
STD CL	SPL CL			
4006	—	Globe	Flanged	3 (80) thru 14 (350)
4006Y	4306Y	Globe	Buttwelding	
4007	—	Angle	Flanged	3 (80) thru 24 (600)
4007Y	4307Y	Angle	Buttwelding	
4002	—	Flite-Flow	Flanged	3 (80) thru 16 (400)
4002Y	4302Y	Flite-Flow	Buttwelding*	

* Size 3&4 Buttweld Flite-Flow Valves are Class 1100 - see page 56.

Dimensions – Globe & Angle

Black numerals are in inches and pounds
Colored numerals are in millimeters and kilograms

Figure No. 4006/4006Y, 4007/4007Y, 4306Y, 4307Y	NPS	3	4	5	6	8	10	12	14
	DN	80	100	125	150	200	250	300	350
A - End to End (Welding)		15	18	22	24	29	33	38	40.5
		381	457	559	610	737	838	965	1029
B - Center to End (Welding)		7.5	9	11	12	14.5	16.5	19	19
		190	229	279	305	368	419	483	483
C - Face to Face (Flanged)		15	18	22	24	29	33	38	40.5
		381	457	559	610	737	838	965	1029
D - Center to Face (Flanged)		7.5	9	11	12	14.5	16.5	19	21.75
		190	229	279	305	368	419	483	552
E - Center to Top, Globe (Open)		22.5	26.25	30.63	37	46	54.75	64.75	71.25
		572	667	778	940	1168	1391	1645	1810
F - Center to Top, Angle (Open)		20.38	23.75	28.25	34.25	43.38	49.25	60	62.75
		518	603	718	870	1102	1251	1524	1594
G - Handwheel Diameter*		16	16	20	20	28	28	36	36
		406	406	508	508	711	711	914	914
H - Clearance for Equalizer		7.5	7.63	9.75	10.75	12.5	12.88	14.75	17.38
		190	194	248	273	318	327	375	441
Weight, Globe (Flanged)		220	314	615	800	1570	2425	3700	4600
		100	142	279	363	712	1100	1665	2087
Weight, Globe (Welding)		175	245	500	642	1400	2300	3100	4750
		79	111	227	291	635	1043	1406	2155
Weight, Angle (Flanged)		206	284	540	690	1360	2103	3010	3060
		93	129	245	313	617	954	1365	1388
Weight, Angle (Welding)		150	215	410	552	1035	1600	2555	2580
		68	98	186	250	469	725	1159	1170

* Impactor handwheel is standard on all valves.

Stop-Check (Non-Return) Valves Class 900 2220 PSI @ 100°F (153.2 BAR @ 38°C)

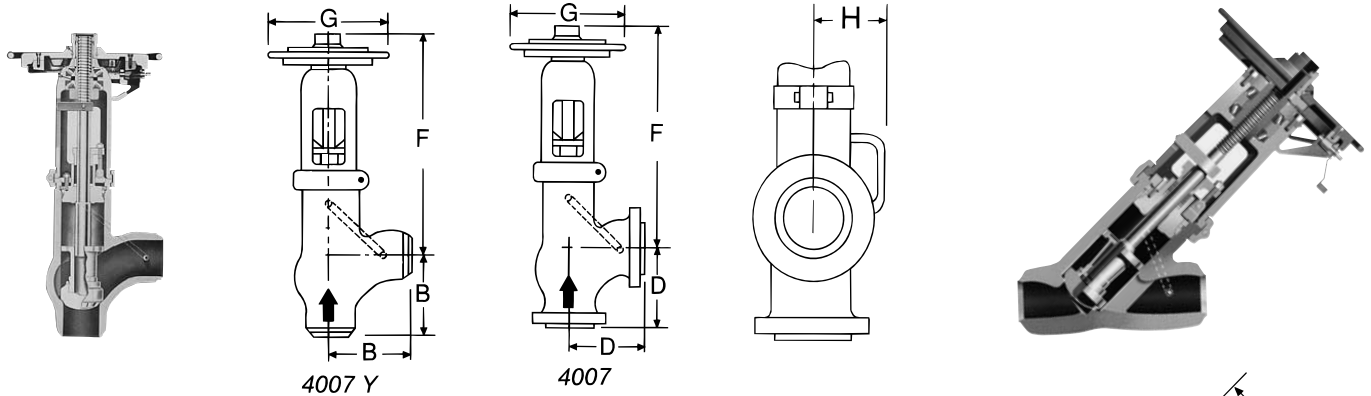

Dimensions – Angle

Black numerals are in inches and pounds
Colored numerals are in millimeters and kilograms

Figure No. 4007/4007Y, 4307Y	NPS	16	18	20	24
	DN	400	450	500	600
B - Center to End (Welding)		26	**	32.5	39
		660		825	991
F - Center to Top, Angle		78.5	**	95	102
		1994		2413	2591
G - Handwheel Diameter*		48	**	72	72
		1219		1829	1829
H - Clearance for Equalizer		20	**	21.5	30
		50.8		546	762
Weight, Angle (Welding)		4960	**	8150	13,750
		2250		3697	6237

** Size 18" Angle - Available Upon Request.

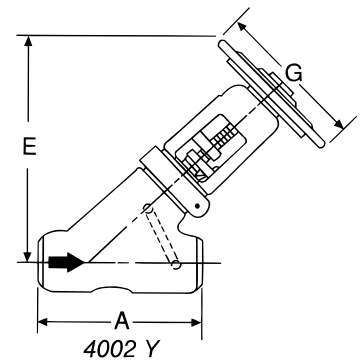

Dimensions – Flite-Flow

Figure No. 4002/4002Y, 4302Y	NPS	3	4	6	8	10	12	14	16
	DN	80	100	150	200	250	300	350	400
A ₁ - End to End (Welding)		17	18.5	20	26	31	38	38	44.5
		432	470	508	660	787	965	965	1130
A ₂ - Face to Face (Flanged)		22.25	23.75	30	38	44	50	51	58
		565	603	762	965	1118	1270	1295	1473
E - Center to Top (Open)		20	25	35	44	51	60	60	73
		508	635	889	1118	1295	1524	1524	1854
G - Handwheel Diameter*		16	16	20	28	28	36	36	48
		406	406	508	711	711	914	914	1219
H - Equalizer Clearance		9	9.3	10	12.5	16	15	15	25.75
		229	236	254	318	406	381	381	654
Weight (Welding)		190	275	555	1150	2100	3400	3400	5550
		86	125	252	522	953	1542	1542	2517
Weight (Flanged)		250	370	775	1550	2650	4150	4550	6950
		113	168	352	703	1202	1882	2064	3153

* Impactor handwheel is standard on all valves.

Note: Size 3&4 Buttweld Class 900 Flite-Flow Valves are Class 1100. See page 56.

Check Valves

Class 900 2220 PSI @ 100°F (153.2 BAR @ 38°C)

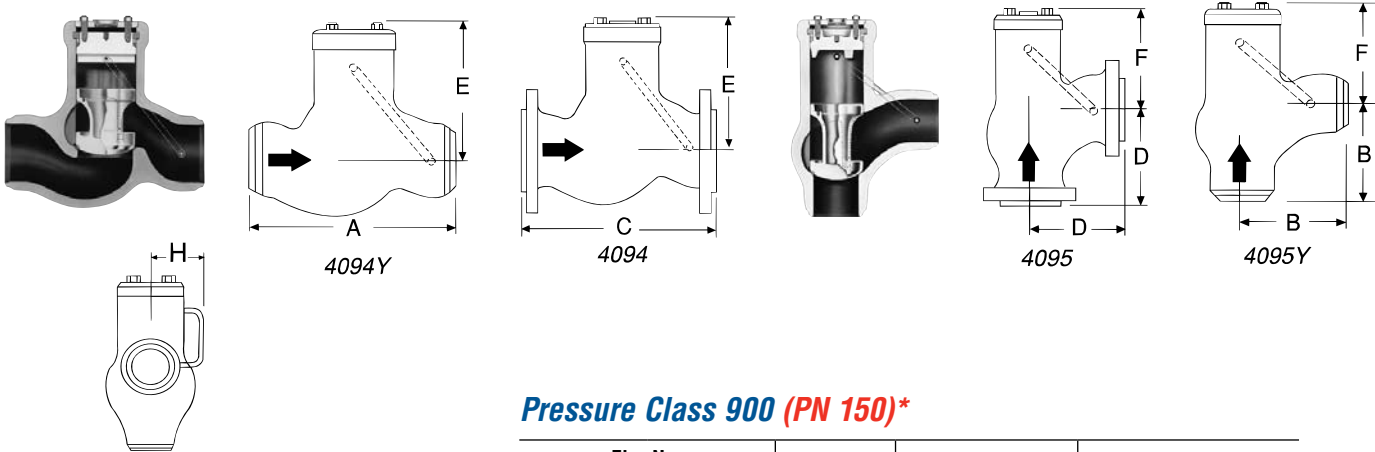

Standard Features

- Bodies and Covers are cast steel (WCB, WC6, WC9, C12A, CF8M or CF8C).
- Pressure-seal Cover.
- Globe, angle & tilting disk design.
- Integral Stellite seats.
- Body-guided disk piston. (Globe & Angle)
- Equipped with equalizer. (Globe & Angle)

Pressure Class 900 (PN 150)*

Fig. No.		Type	Ends	NPS (DN)
STD CL	SPL CL			
970Y	4370Y	Tilting Disk	Buttwelding	2½ (65) thru 24 (600)
4094	—	Globe	Flanged	3 (80) thru 14 (350)
4094Y	4394Y	Globe	Buttwelding	
4095	—	Angle	Flanged	3 (80) thru 24 (600)
4095Y	4395Y	Angle	Buttwelding	
4092	—	Flite-Flow	Flanged	3 (80) thru 16 (400)
4092Y	4392Y	Flite-Flow	Buttwelding*	

*Size 3&4 Buttweld Flite-Flow Valves are Class 1100 - see page 57.

Dimensions – Globe & Angle

Black numerals are in inches and pounds
Colored numerals are in millimeters and kilograms

Figure No. 4094/4094Y, 4095/4095Y, 4394Y, 4395Y	NPS	3	4	5	6	8	10	12	14
	DN	80	100	125	150	200	250	300	350
A - End to End (Welding)		15	18	22	24	29	33	38	40.5
		381	457	559	610	737	838	965	1029
B - Center to End (Welding)		7.5	9	11	12	14.5	16.5	19	20.25
		190	229	279	305	368	419	483	514
C - Face to Face (Flanged)		15	18	22	24	29	33	38	40.5
		381	457	559	610	737	838	965	1029
D - Center to Face (Flanged)		7.5	9	11	12	14.5	16.5	19	20.25
		190	229	279	305	368	419	483	514
E - Center to Top, Globe		11	12	13.75	15.63	18.5	22.25	26.25	28.75
		279	305	349	397	470	565	667	730
F - Center to Top, Angle		9.25	10.25	11.25	12.5	16	16.75	21.5	21.5
		235	260	286	318	406	425	546	546
H - Clearance for Equalizer		7.5	7.63	9.75	10.75	12.5	12.88	14.75	17.38
		190	194	248	273	318	327	275	441
Weight, Globe (Flanged)		140	246	426	550	1188	1310	2710	3820
		64	112	193	249	539	594	1229	1733
Weight, Globe (Welding)		108	160	272	400	840	1090	2110	3070
		49	73	123	181	381	494	957	1393
Weight, Angle (Flanged)		134	217	356	485	898	1080	2165	2345
		61	98	161	220	407	490	982	1064
Weight, Angle (Welding)		115	131	202	290	510	860	1565	1860
		52	59	92	132	231	390	710	844

Check Valves

Class 900 2220 PSI @ 100°F (153.2 BAR @ 38°C)

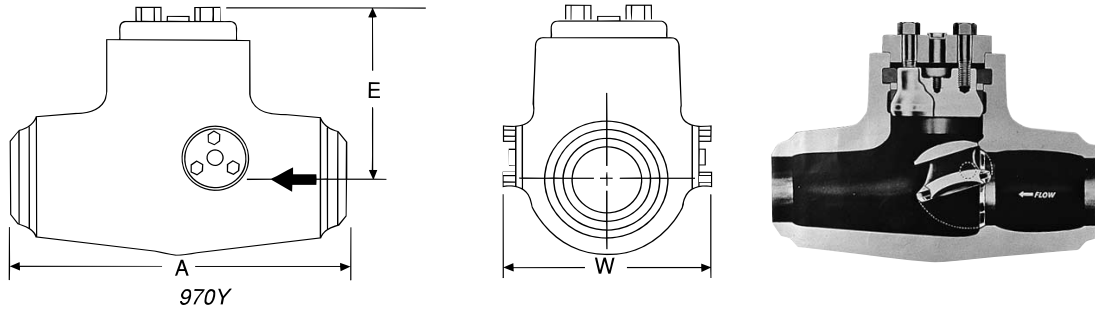

Dimensions – Angle

Black numerals are in inches and pounds
Colored numerals are in millimeters and kilograms

Figure No. 4095/4095Y, 4395Y	NPS	16	18	20	24
	DN	400	450	500	600
B - Center to End, (Welding)		26	29	32.5	39
		660	737	825	991
F - Center to Top, Angle (Open)		29	32	32	36
		737	813	813	914
G - Handwheel Diameter		20	21	21.5	30
		508	533	546	762
Weight, Angle (Welding)		2675	3710	4930	8190
		1213	1682	2636	3714

Dimensions – Tilting Disk

Figure No. 970Y, 4370Y	NPS	2½*	3*	4*	6	8	10
	DN	65	80	100	150	200	250
A - End to End (Welding)		12	12	12	22	28	34
		305	305	305	559	711	864
E - Center to Top		7.25	7.25	7.25	9.25	11	13
		184	184	184	235	279	330
W - Width		10.5	10.5	10.5	16.5	16	20.5
		267	267	267	419	406	521
Weight (Welding)		95	95	120	535	600	1010
		43	43	54	243	272	458

* Spiral wound hinge pin gaskets; hinge pin torsion spring not required.

Figure No. 970Y, 4370Y	NPS	12	14	16	18	20	24
	DN	300	350	400	450	500	600
A - End to End (Welding)		42	40.5	47	53	51.5	78
		1067	1029	1194	1346	1308	1981
E - Center to Top		15.75	15.75	18.75	18.75	23	36
		400	400	476	476	584	914
W - Width		26.5	26.5	29	29	37.5	55
		673	673	737	737	953	1397
Weight (Welding)		2090	2090	3260	3300	4510	10,200
		948	948	1479	1497	2046	4627

Check Valves

Class 900 2200 PSI @ 100°F (153.2 BAR @ 38°C)

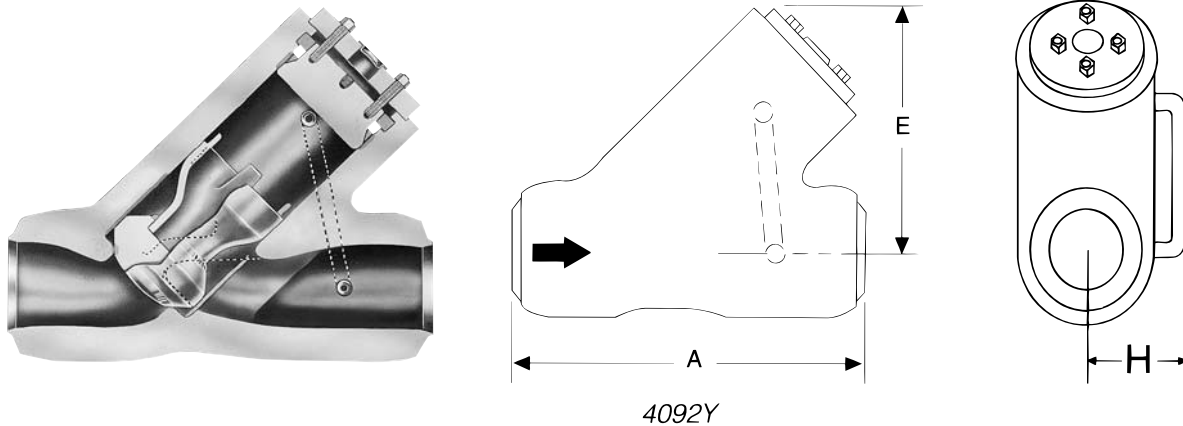

Standard Features

- Bodies and covers are cast steel (WCB, WC6, WC9, C12A, CF8M or CF8C).
- Pressure-seal cover.
- Y-Pattern.
- Integral Stellite seats.
- Body-guided disk piston.
- Equipped with equalizer.

Dimensions – Flite-Flow

Black numerals are in inches and pounds
Colored numerals are in millimeters and kilograms

Figure No. 4092/4092Y, 4392Y	NPS	3	4	6	8	10	12	14	16
	DN	80	100	150	200	250	300	350	400
A ₁ - End to End (Welding)		17	18.5	20	26	31	38	38	44.5
		432	470	508	660	787	914	914	1092
A ₂ - Face to Face (Flanged)		22.25	23.75	30	38	44	50	51	58
		565	603	762	965	1118	1270	1295	1473
E - Center to Top		10	11	13.5	17.25	20.25	24	24	30
		254	279	343	438	514	610	610	762
H - Equalizer Clearance		9	9.3	10	12.5	16	15	15	25.75
		229	236	254	318	406	381	381	654
Weight (Welding)		130	175	300	710	1300	2050	2050	3900
		59	79	136	322	590	930	930	1769
Weight (Flanged)		190	250	520	1100	1850	2800	3200	5300
		86	113	236	499	839	1270	1452	2404

* Impactor handwheel is standard on all valves.

Note: Size 3&4 Butt-weld Class 900 Flite-Flow Valves are Class 1100. See page 57.

Stop Valves

Class 1100 2715 PSI @ 100°F (187.2 BAR @ 38°C)

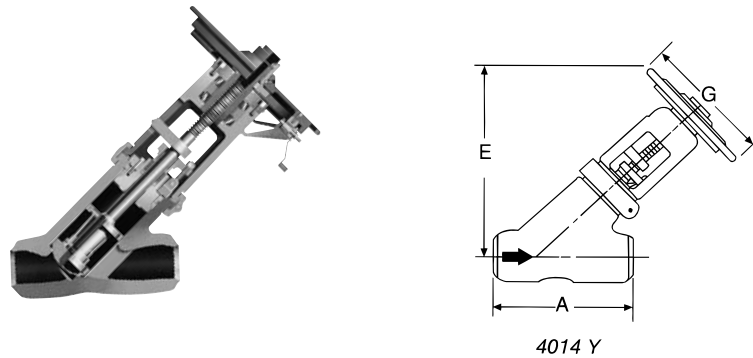

Standard Features

- Bodies and bonnets are cast steel (WCB, WC6, WC9, C12A, CF8M, or CF8C).
- Pressure-seal bonnet, OS & Y.
- Y-Pattern.
- Integral Stellite seat, disk and backseat.
- Body-guided disk piston.
- 13% chromium stainless steel stem.
- Asbestos-free graphitic packing.

Pressure Class 1100 (PN 190)

Fig. No.		Type	Ends	NPS (DN)
STD CL	SPL CL			
4014Y	4314Y	Flite-Flow	Buttwelding	3 (80) and 4 (100)

Dimensions – Flite-Flow®

Black numerals are in inches and pounds
Colored numerals are in millimeters and kilograms

Figure No. 4014Y, 4314Y	NPS	3	4
	DN	80	100
A - End to End (Welding)		17	18.5
		432	470
E - Center to Top (Open)		20	25
		508	635
G - Handwheel Diameter*		16	16
		406	406
Weight (Welding)		190	275
		86	125

* Impactor handwheel is standard on all valves.

Stop-Check (Non-Return) Valves

Class 1100 2715 PSI @ 100°F (187.2 BAR @ 38°C)

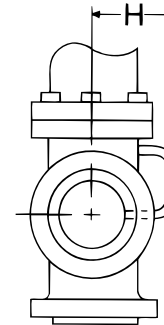
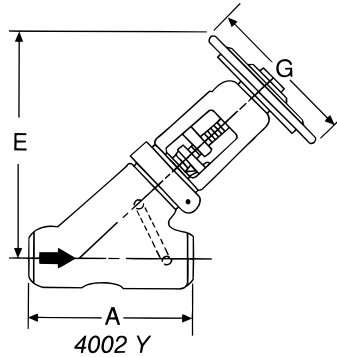
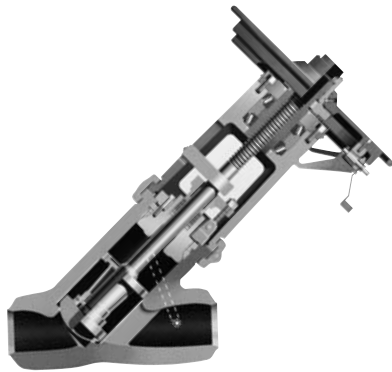

Standard Features

- Bodies and bonnets are cast steel (WCB, WC6, WC9, C12A, CF8M, or CF8C).
- Pressure-seal bonnet, OS & Y.
- Y-Pattern.
- Integral Stellite seat, disk and backseat.
- Body-guided disk piston.
- 13% chromium stainless steel stem.
- Asbestos-free graphitic packing.
- Equipped with equalizer.

Pressure Class 1100 (PN 190)

Fig. No.		Type	Ends	NPS (DN)
STD CL	SPL CL			
4002Y	4302Y	Flite-Flow	Buttwelding	3 (80) and 4 (100)

Dimensions – Flite-Flow®

Black numerals are in inches and pounds
Colored numerals are in millimeters and kilograms

Figure No. 4002Y, 4302Y	NPS	3	4
	DN	80	100
A - End to End (Welding)		17	18.5
		432	470
E - Center to Top (Open)		20	25
		508	635
G - Handwheel Diameter*		16	16
		406	406
H - Equalizer Clearance		9	10
		229	254
Weight (Welding)		190	275
		86	125

* Impactor handwheel is standard on all valves.

Check Valves Class 1100 2715 PSI @ 100°F (187.2 BAR @ 38°C)

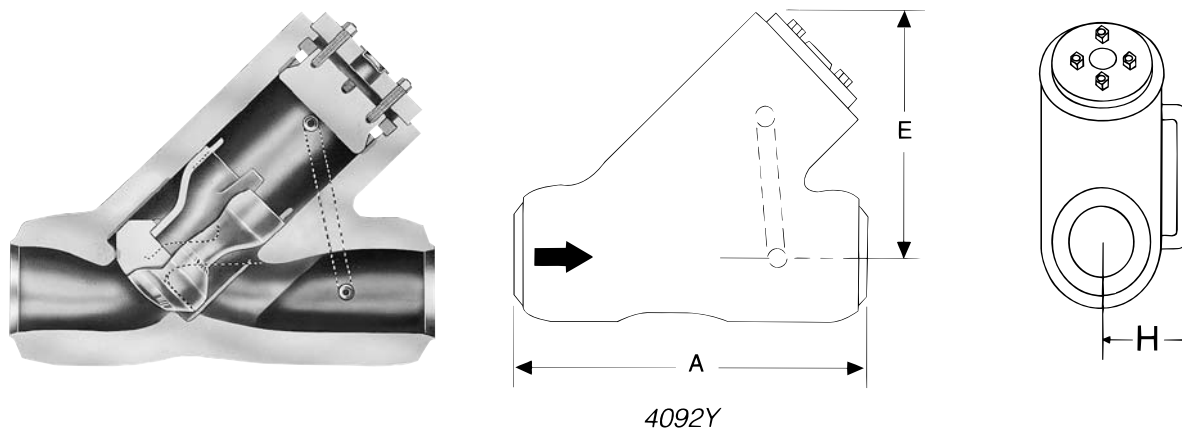

Standard Features

- Bodies and covers are cast steel (WCB, WC6, WC9, C12A, CF8M, or CF8C).
- Pressure-seal cover.
- Y-Pattern.
- Integral Stellite seat and disk.
- Body-guided disk piston.
- Equipped with equalizer.

Pressure Class 1100 (PN 190)

Fig. No.		Type	Ends	NPS (DN)
STD CL	SPL CL			
4092Y	4392Y	Flite-Flow	Buttwelding	3 (80) and 4 (100)

Dimensions – Flite-Flow®

Black numerals are in inches and pounds
Colored numerals are in millimeters and kilograms

Figure No. 4092Y, 4392Y	NPS	3	4
	DN	80	100
A - End to End (Welding)		17	18.5
		432	470
E - Center to Top		10	11
		254	279
H - Equalizer Clearance		9	10
		229	254
Weight (Welding)		130	175
		59	79

Stop-Check & Check Valves Elbow Down

Flowserve Edward Elbow Down stop-check valves are available for special service requirements. Consult the Flowserve sales representative for application and design details.

Because they eliminate the need for a piping elbow, and at the same time offer tight shut-off with minimum pressure drop, they are commonly used at discharge of circulating pumps on controlled circulation boilers.

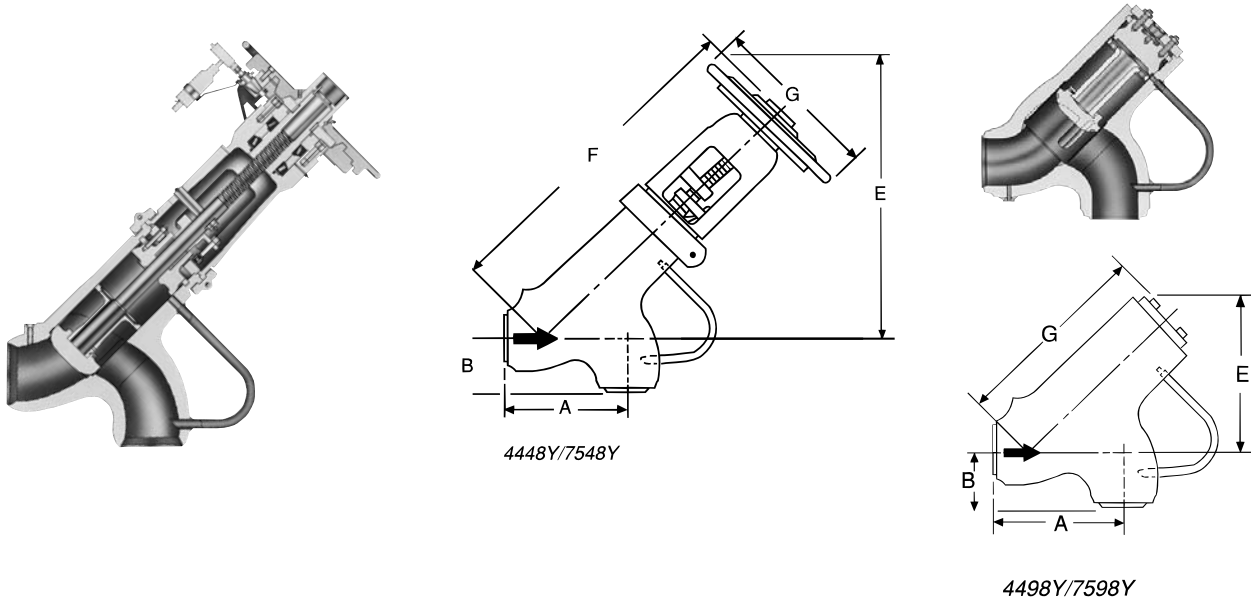

Standard Features

- Bodies and bonnets/covers are cast steel (WCB or WC6).
- Pressure seal bonnet/cover.
- Integral Stellite seat, disk seating & backseat.
- Disk body-guided.
- Impactor handwheel/impactogear.
- Equipped with equalizer.
- Butt welding ends.
- Asbestos-free packing.

Elbow Down*

FIG. NO.	TYPE	ENDS	NPS (DN)
4448Y	Stop Check	Buttwelding	10 (250)
4498Y	Check	Buttwelding	thru 16 (400)
7548Y	Stop Check	Buttwelding	10 (250)
7598Y	Check	Buttwelding	thru 18 (450)

* Pressure temperature ratings available on request.

Dimensions

Black numerals are in inches and pounds
Colored numerals are in millimeters and kilograms

Figure No. 4448Y, 4498Y	NPS	10	12	14	16
	DN	250	300	350	400
A - Center to End, (Inlet)		23	27.56	35.06	34
		584	700	891	864
B - Center to End, (Outlet)		12.25	14.56	18.94	18.56
		311	370	481	471

E, F & G upon request.

Dimensions

Figure No. 7548Y, 7598Y	NPS	10	12	14	16	18
	DN	250	300	350	400	450
A - Center to End, (Inlet)		23	27	29	36	39.25
		584	675	737	914	997
B - Center to End, (Outlet)		13	14	15	17	21.25
		330	356	381	432	540

E, F & G upon request.

Stop Valves

Class 1500 3705 PSI @ 100°F (255.3 BAR @ 38°C)

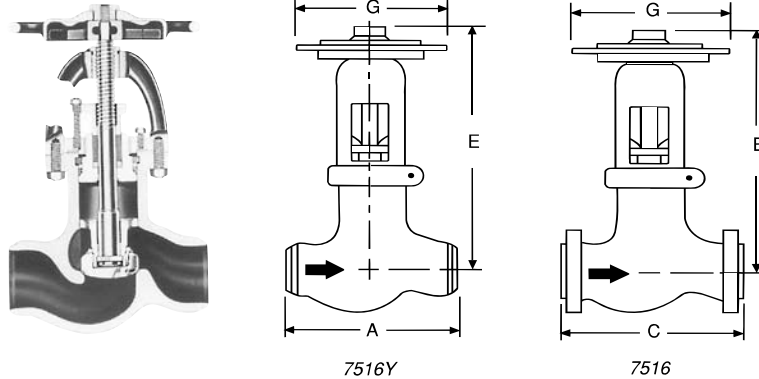

Standard Features

- Bodies and bonnets are cast steel (WCB, WC6, WC9, C12A, CF8M or CF8C).
- Pressure-seal bonnet, OS & Y.
- Y-Pattern, globe & angle design.
- Integral Stellite seats and backseat.
- Body-guided disk piston.
- 13% chromium stainless steel stem.
- Asbestos-free graphitic packing.
- Yoke bushing thrust bearings size 5 and larger.

Pressure Class 1500 (PN 260)*

Fig. No.		Type	Ends	NPS (DN)
STD CL	SPL CL			
7514Y	2014Y	Flite-Flow	Buttwelding*	3 (80) thru 24 (600)
7516	—	Globe	Flanged	2½ (65) thru 14 (350)
7516Y	2016Y	Globe	Buttwelding	
7517	—	Angle	Flanged	2½ (65) thru 24 (600)
7517Y	2017Y	Angle	Buttwelding	

*Size 3&4 Buttweld Flite-Flow Valves are Class 1800. See page 69.

Dimensions – Globe & Angle

Black numerals are in inches and pounds
Colored numerals are in millimeters and kilograms

Figure No. 7516/7516Y, 2016Y 7517/7517Y, 2017Y	NPS	2½	3	4	5	6	8	10	12	14
	DN	65	80	100	125	150	200	250	300	350
A - End to End (Welding)		13	15	18	22	24	29	33	38	40.5
		330	381	457	559	610	737	838	965	1029
B - Center to End (Welding)		6.5	7.5	9	11	12	14.5	16.5	19	20.25
		165	190	229	279	305	368	419	483	514
C - End to End (Flanged)		16.5	18.5	21.5	26.5	27.75	32.75	39	44.5	49.5
		419	470	546	673	705	832	991	1130	1257
D - Center to End (Flanged)		8.25	9.25	10.75	13.25	13.88	16.38	19.5	22.25	24.75
		210	235	273	337	353	416	495	565	629
E - Center to Top, Globe (Open)		19.25	22.5	26.25	30.63	36.5	48.75	59.5	70	70
		489	572	667	778	927	1238	1511	1778	1778
F - Center to Top, Angle (Open)		18	20.4	23.75	28.25	34.75	45.75	56	66.3	66.75
		457	518	603	718	883	1162	1422	1684	1695
G - Handwheel Diameter*		14	16	16	20	20	28	36	36	48
		356	406	406	508	508	711	914	914	1219
Weight, Globe (Flanged)		167	260	385	760	960	1800	3150	4910	5900
		76	118	175	345	435	816	1429	2227	2676
Weight, Globe (Welding)		90	175	270	525	700	1620	2600	3710	4850
		41	79	122	238	317	735	1179	1683	2200
Weight, Angle (Flanged)		153	230	330	730	865	1580	2780	4100	4850
		69	104	150	331	392	717	1261	1860	2200
Weight, Angle (Welding)		80	150	255	510	670	1250	2200	2900	3800
		36	68	116	231	304	567	998	1315	1724

*Impactor handle is standard on size 2½ Globe and Angle valves.

*Impactor handwheel is standard on all other size Globe and Angle valves and all Flite-Flow valves.

*Impactogear is available on size 8 and larger Globe, Angle and Flite-Flow valves.

Stop Valves

Class 1500 3705 PSI @ 100°F (255.3 BAR @ 38°C)

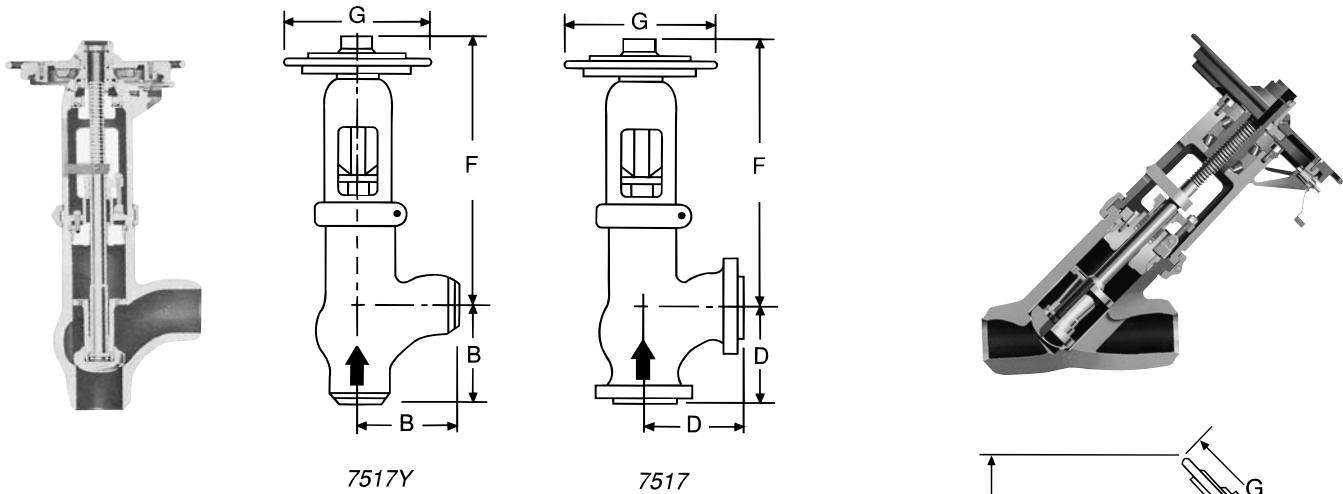

Dimensions – Globe & Angle

Black numerals are in inches and pounds
Colored numerals are in millimeters and kilograms

Figure No. 7517/7517Y, 2017Y	NPS	16	18	20	24
	DN	400	450	500	600
B - Center to End (Welding)		23.5	23.5	28.5	35.5
		597	597	724	902
F - Center to Top, Angle		77.5	77.5	84	103
		1969	1969	2134	2616
G - Handwheel Diameter*		48	48	72	72
		1219	1219	1829	1829
Weight, Angle (Welding)		6600	6800	9500	16,200
		2994	3084	4309	7348

Dimensions – Flite-Flow®

Figure No. 7514Y/2014Y	NPS	3	4	6	8	10	12	14	16	18	20	24
	DN	80	100	150	200	250	300	350	400	450	500	600
A - End to End (Welding)		17	18.5	27.75	30	36.25	43	41	54	63	54.5	59.5
		432	470	705	762	921	1092	1041	1372	1600	1384	1511
E - Center to Top (Open)		20	25	34.25	45	53.5	60.75	60.75	78.5	78.5	96	96
		508	635	870	1143	1359	1543	1543	1994	1994	2438	2438
G - Handwheel Diameter*		16	16	20	28	36	36	36	48	48	72	72
		406	406	508	711	914	914	914	1219	1219	1829	1829
Weight (Welding)		210	300	700	1550	2725	4220	4300	7650	8390	10,500	16,800
		95	136	318	702	1236	1914	1950	3470	3806	4763	7620

*Impactor handle is standard on size 2½ Globe and Angle valves.
 *Impactor handwheel is standard on all other size Globe and Angle valves and all Flite-Flow valves.
 *Impactogear is available on size 8 and larger Globe, Angle and Flite-Flow valves.
 Note: Size 3&4 Butt-weld Class 1500 Flite-Flow Valves are Class 1800. See page 69.

Stop Valves

Class 1500 3705 PSI @ 100°F (255.3 BAR @ 38°C)

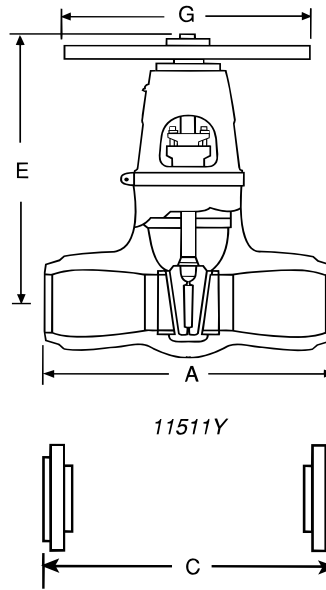

Standard Features

- Bodies and bonnets are cast steel (WCB, WC6, WC9,C12A, CF8M or CF8C).
- Pressure-seal bonnet, OS & Y.
- Integral Stellite seats and backseat.
- Two-piece body-guided wedge.
- 13% chromium stainless steel stem.
- Asbestos-free graphitic packing.
- Available in standard or venturi pattern.
- Yoke bushing thrust bearings.

Pressure Class 1500 (PN 260)

Fig. No.		Type	Ends	NPS (DN)
STD CL	SPL CL			
11511	—	Equiwedge Gate	Flanged*	2½ (65) thru 24 (600)
11511Y	12011Y	Equiwedge Gate	Buttwelding	
11511BY	12011BY	Venturi Pattern Equiwedge Gate	Buttwelding	8 (200) thru 28 (700)

* Optional weld-on flanges.

Dimensions – Equiwedge Gate

Black numerals are in inches and pounds
Colored numerals are in millimeters and kilograms

Figure No. 11511/11511Y, 12011Y	NPS	2½	3	4	6	8	10	12
	DN	65	80	100	150	200	250	300
A - End to End (Welding)		12	12	16	22	28	34	39
		305	305	406	559	711	864	991
C - Face to Face (Flanged)		16.5	18.5	21.5	27.75	32.75	39	44.5
		419	470	546	705	832	991	1130
E - Center to Top (Open)		21.25	21.25	24.25	31.5	40	48.25	55.25
		540	540	616	800	1016	1226	1403
G - Handwheel Diameter		14	14	18	24	36	36	36
		356	356	457	610	914	914	914
Weight (Welding)		125	125	190	490	675	1730	2725
		57	57	86	222	306	785	1236

Stop Valves

Class 1500 3705 PSI @ 100°F (255.3 BAR @ 38°C)

Dimensions – Equiweedge Gate (continued)

Black numerals are in inches and pounds
Colored numerals are in millimeters and kilograms

Figure No. 11511/11511Y, 12011Y	NPS	14	16	18	20	22	24
	DN	350	400	450	500	550	600
A - End to End (Welding)		42	47	53	58	67	76.5
		1067	1194	1346	1473	1702	1943
C - Face to Face (Flanged)		49.5	54.5	60.5	65.5	71	76.5
		1257	1384	1537	1664	1803	1943
E - Center to Top (Open)		61	68.75	73.75	80	86.75	93.5
		1549	1746	1873	2032	2203	2375
G - Handwheel Diameter		48	48	48	60	60	60
		1219	1219	1219	1524	1524	1524
Weight (Welding)		3660	4450	6000	8000	10,500	13,000
		1660	2019	2722	3629	4763	5897

Dimensions – Equiweedge Gate Venturi Pattern

Black numerals are in inches and pounds
Colored numerals are in millimeters and kilograms

Figure No. 11511BY, 12011BY	NPS	8x6x8	10x8x10	12x10x12	14x12x14	16x14x16	18x16x18
	DN	200	250	300	350	400	450
A - End to End (Welding)		22	28	34	39	42	47
		559	711	864	991	1067	1194
E - Center to Top (Open)		31.5	40	48.25	55.25	61	68.75
		800	1016	1226	1403	1549	1746
G - Handwheel Diameter		24	36	36	36	48	48
		610	914	914	914	1219	1219
Weight (Welding)		490	1082	1690	2725	3600	4600
		222	491	767	1236	1633	2087

Figure No. 11511BY, 12011BY	NPS	20x18x20	22x20x22	24x20x24	26x22x26	28x24x28
	DN	500	550	600	650	700
A - End to End (Welding)		53	58	58	67	76.5
		1346	1473	1473	1702	1943
E - Center to Top (Open)		73.75	80	80	86.75	93.5
		1873	2032	2032	2203	2375
G - Handwheel Diameter		48	60	60	60	60
		1219	1524	1524	1524	1524
Weight (Welding)		6200	8200	8,500	11,000	13,500
		2812	3720	3855	4990	6124

Stop-Check (Non-Return) Valves

Class 1500 3705 PSI @ 100°F (255.3 BAR @ 38°C)

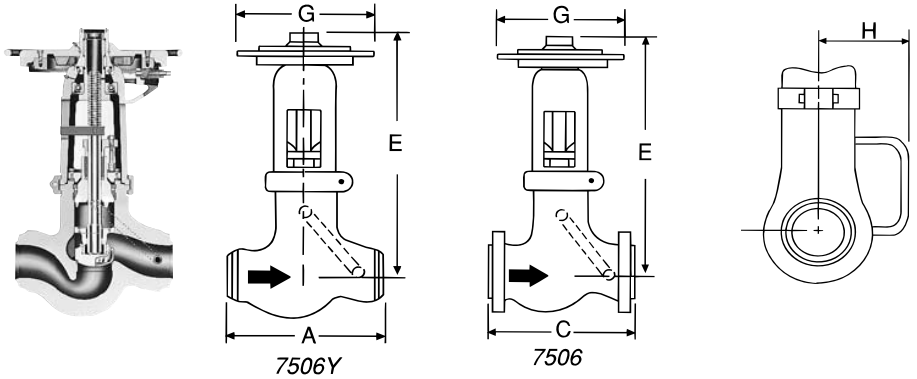

Standard Features

- Bodies and bonnets are cast steel (WCB, WC6, WC9, C12A, CF8M or CF8C).
- Pressure-seal bonnet, OS & Y.
- Y-Pattern, globe or angle design.
- Integral Stellite seats and backseat.
- Body-guided disk piston.
- 13% chromium stainless steel stem.
- Asbestos-free graphitic packing.
- Equipped with equalizer.
- Yoke bushing thrust bearings size 5 and larger.

Pressure Class 1500 (PN 260)*

FIG. NO.		TYPE	ENDS	NPS (DN)
STD CL	SPL CL			
7502Y	2002Y	Flite-Flow	Buttwelding*	3 (80) thru 24 (600)
7506	—	Globe	Flanged	2½ (65) thru 14 (350)
7506Y	2006Y	Globe	Buttwelding	
7507	—	Angle	Flanged	2½ (65) thru 24 (600)
7507Y	2007Y	Angle	Buttwelding	

* Size 3 & 4 Buttweld Flite-Flow Valves are Class 1800. See page 70.

Dimensions – Globe & Angle

Black numerals are in inches and pounds
Colored numerals are in millimeters and kilograms

Figure No. 7506/7506Y, 7507/7507Y, 2006Y, 2007Y	NPS	2½	3	4	5	6	8	10	12	14
	DN	65	80	100	125	150	200	250	300	350
A - End to End (Welding)		13	15	18	22	24	29	33	38	40.5
		330	381	457	559	610	737	838	965	1029
B - Center to End (Welding)		6.5	7.5	9	11	12	14.5	16.5	19	20.25
		165	190	229	279	305	368	419	483	514
C - Face to Face (Flanged)		16.5	18.5	21.5	26.5	27.75	32.75	39	44.5	49.5
		419	470	546	673	705	832	991	1130	1257
D - Center to Face (Flanged)		8.25	9.25	10.75	13.25	13.88	16.38	19.5	22.25	24.75
		210	235	273	337	353	416	495	565	628
E - Center to Top, Globe		19.25	22.5	26.25	30.63	36.5	48.75	59.5	70	70
		489	572	667	778	927	1238	1511	1778	1778
F - Center to Top, Angle		18	20.38	23.75	28.25	34.75	45.75	56	66.3	66.75
		457	518	603	718	883	1162	1422	1684	1695
G - Handwheel Diameter*		14	16	16	20	20	28	36	36	48
		356	406	406	508	508	711	914	914	1219
H - Clearance for Equalizer		6.75	7.75	7.75	10	10.75	12.75	14	15	17.38
		171	197	197	254	273	324	356	381	441
Weight, Globe (Flanged)		167	270	385	770	960	1800	3150	4910	5900
		76	122	175	349	435	816	1429	2227	2676
Weight, Globe (Welding)		90	180	270	570	710	1470	2600	3710	4850
		41	82	122	258	322	667	1179	1683	2200
Weight, Angle (Flanged)		153	230	330	730	865	1580	2780	4100	4850
		69	104	149	331	392	717	1261	1860	2200
Weight, Angle (Welding)		77	160	255	510	585	1250	2200	2900	3800
		35	73	116	231	265	567	998	1315	1724

*Impactor handle is standard on size 2½ Globe and Angle valves.

*Impactor handwheel is standard on all other size Globe and Angle valves and all Flite-Flow valves.

*Impactogear is available on size 8 and larger Globe, Angle and Flite-Flow valves.

Stop-Check (Non-Return) Valves Class 1500 3705 PSI @ 100°F (255.3 BAR @ 38°C)

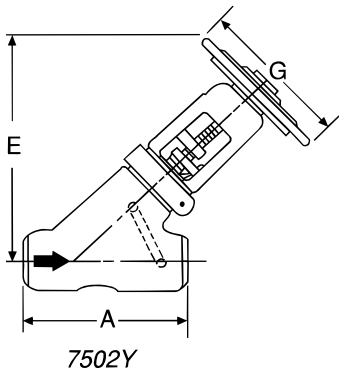
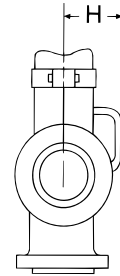
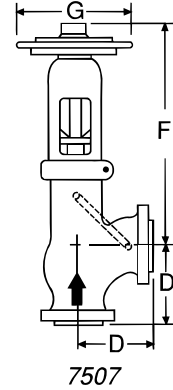
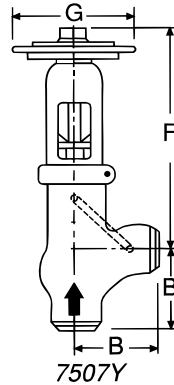
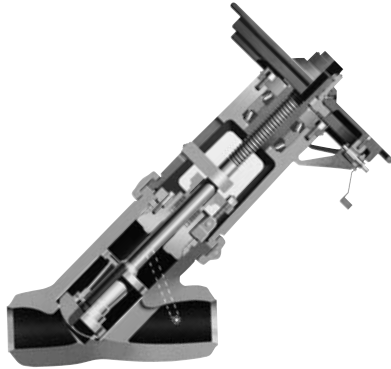

Dimensions – Angle

Black numerals are in inches and pounds
Colored numerals are in millimeters and kilograms

Figure No. 7507/7507Y, 2007Y	NPS	16	18	20	24
	DN	400	450	500	600
B - Center to End (Welding)		23.5	23.5	28.5	35.5
		597	597	724	902
F - Center to Top, Angle		77.5	77.5	84	103
		1969	1969	2134	2616
G - Handwheel Diameter*		48	48	72	72
		1219	1219	1829	1829
H - Clearance for Equalizer		19.5	19.5	23	28.5
		495	495	584	724
Weight, Angle (Welding)		6600	6800	9500	16,200
		2994	3084	4309	7348

Dimensions – Flite-Flow

Figure No. 7502Y, 2002Y	NPS	3	4	6	8	10	12	14	16	18	20	24
	DN	80	100	150	200	250	300	350	400	450	500	600
A - End to End (Welding)		17	18.5	27.75	30	36.25	43	41	54	63	54.5	59.5
		432	470	705	762	921	1092	1041	1372	1600	1384	1511
E - Center to Top		20	25	34.25	45	53.5	60.75	60.75	78.5	78.5	96	96
		508	635	870	1143	1359	1543	1543	1994	1994	2438	2438
G - Handwheel Diameter*		16	16	20	28	36	36	36	48	48	72	72
		406	406	508	711	914	914	914	1219	1219	1829	1829
H - Equalizer Clearance		9	10	10.75	12.75	15.75	16.5	16.5	19.5	19.5	28	28
		229	254	273	324	400	419	419	495	495	711	711
Weight (Welding)		210	300	720	1600	2820	4260	4280	8450	8400	10,500	11,500
		95	136	327	726	1279	1932	1941	3833	3810	4763	5216

*Impactor handle is standard on size 2½ Globe and Angle valves.

*Impactor handwheel is standard on all other size Globe and Angle valves and all Flite-Flow valves.

*Impactogear is available on size 8 and larger Globe, Angle and Flite-Flow valves.

Note: Size 3&4 Butt-weld Class 1500 Flite-Flow Valves are Class 1800. See page 70.

Check Valves

Class 1500 3705 PSI @ 100°F (255.3 BAR @ 38°C)

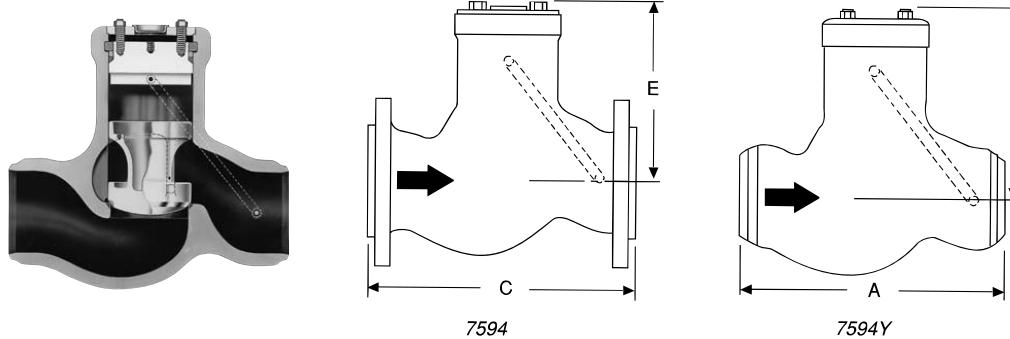

Standard Features

- Bodies and covers are cast steel (WCB, WC6, WC9, C12A, CF8M or CF8C).
- Pressure-seal cover OS & Y.
- Globe or angle design.
- Integral Stellite seats.
- Body-guided disk piston.
- Equipped with equalizer.

Pressure Class 1500 (PN 260)*

Fig. No.		Type	Ends	NPS (DN)
STD CL	SPL CL			
7594	—	Globe	Flanged	2½ (65) thru 14 (350)
7594Y	2094Y	Globe	Buttwelding	
7595	—	Angle	Flanged	2½ (65) thru 24 (600)
7595Y	2095Y	Angle	Buttwelding	
7592Y	2092Y	Flite-Flow	Buttwelding*	3 (80) thru 24 (600)

*Size 3&4 Buttweld Flite-Flow Valves are Class 1800. See page 71.

Dimensions – Globe & Angle

Black numerals are in inches and pounds
Colored numerals are in millimeters and kilograms

Figure No. 2094Y, 2095Y, 7594/7594Y, 7595/7595Y	NPS	2½	3	4	5	6	8	10
	DN	65	80	100	125	150	200	250
A - End to End (Welding)		13	15	18	22	24	29	33
		330	381	457	559	610	737	838
B - Center to End (Welding)		6.5	7.5	9	11	12	14.5	16.5
		165	190	229	279	305	368	419
C - Face to Face (Flanged)		16.5	18.5	21.5	26.5	27.75	32.75	39
		419	470	546	673	705	832	991
D - Center to Face (Flanged)		8.25	9.25	10.75	13.25	13.88	16.38	19.5
		210	235	273	337	353	416	495
E - Center to top, Globe		9.25	11	12	13.75	15	18.75	20.75
		235	279	305	349	381	476	527
F - Center to Top, Angle		8.25	9.25	10.25	11.25	13	15.75	17.25
		210	235	260	286	330	400	438
H - Clearance for Equalizer		6.75	7.75	7.75	10	10.75	12.75	14
		171	197	197	254	273	324	356
Weight, Globe (Flanged)		125	195	320	534	684	1390	2360
		57	88	145	242	310	631	1070
Weight, Globe (Welding)		65	115	180	308	470	960	1530
		29	52	82	140	213	435	694
Weight, Angle (Flanged)		107	186	290	350	470	1070	1060
		49	84	132	159	213	485	481
Weight, Angle (Welding)		57	94	152	260	340	680	1230
		26	43	69	118	154	308	558

Check Valves

Class 1500 3705 PSI @ 100°F (255.3 BAR @ 38°C)

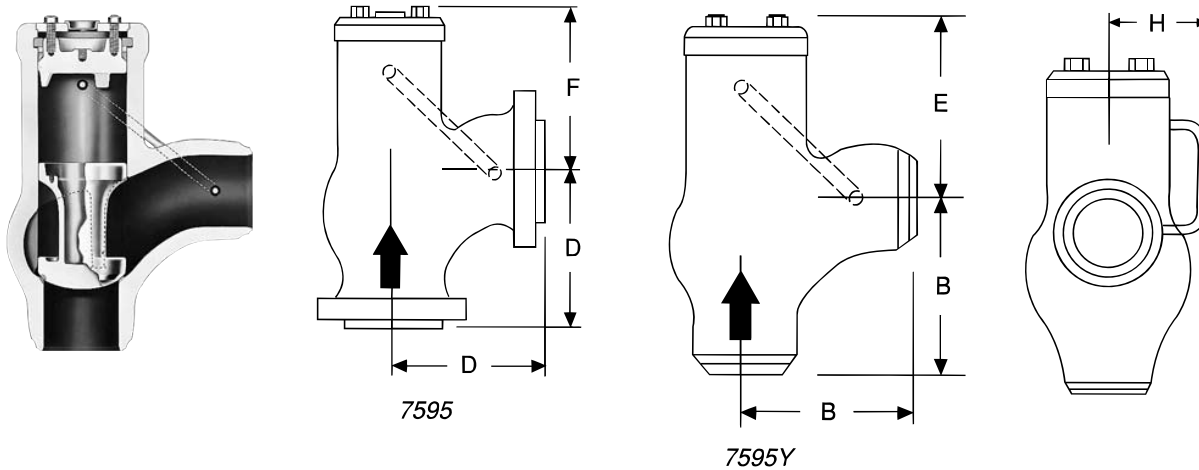

Dimensions – Globe & Angle

Black numerals are in inches and pounds
Colored numerals are in millimeters and kilograms

Figure No. 2094Y, 2095Y, 7594/7594Y, 7595/7595Y	NPS	12	14	16	18	20	24
	DN	300	350	400	450	500	600
A - End to End (Welding)		38	40.5	Valve Not Available			
		965	1029				
B - Center to End (Welding)		19	20.25	23.5	23.5	28.5	35.5
		483	514	597	597	724	902
C - Face to Face (Flanged)		44.5	49.5	Valve Not Available			
		1130	1257				
D - Center to Face (Flanged)		22.25	24.75	Available Upon Request			
		565	629				
E - Center to Top, Globe		24.25	30	Valve Not Available			
		616	762				
F - Center to Top, Angle		20.5	25	24.5	24.5	42	51
		521	635	622	622	1067	1295
H - Clearance for Equalizer		15	17.38	19.5	19.5	23	28.5
		381	441	495	495	584	724
Weight, Globe (Flanged)		3100	4400	Valve Not Available			
		1406	1995				
Weight, Globe (Welding)		2310	3300	Available Upon Request			
		1040	1497				
Weight, Angle (Flanged)		2320	3900	Valve Not Available			
		1044	1769				
Weight, Angle (Welding)		1530	2060	4700	4880	6820	11,600
		686	927	2131	2213	3093	5261

Check Valves

Class 1500 3705 PSI @ 100°F (255.3 BAR @ 38°C)

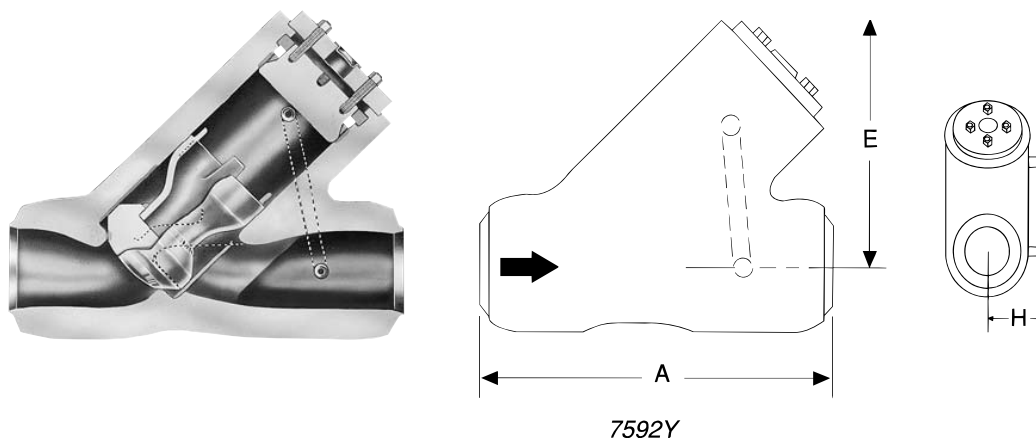

Standard Features

- Bodies and covers are cast steel (WCB, WC6, WC9, C12A, CF8M or CF8C).
- Pressure-seal cover.
- Y-Pattern.
- Integral Stellite seats.
- Body-guided disk piston.
- Equipped with equalizer.

Dimensions – Flite-Flow

Black numerals are in inches and pounds
Colored numerals are in millimeters and kilograms

Figure No. 2092Y, 7592Y	NPS	3	4	6	8	10	12	14	16	18	20	24
	DN	80	100	150	200	250	300	350	400	450	500	600
A - End to End		17	18.5	27.75	30	36.25	43	41	54	63	54.5	58
		432	470	705	762	921	1092	1041	1372	1600	1384	1478
E - Center to Top		10	11	16	20.75	25.5	29.25	29.25	34	34	43	43
		254	279	406	527	648	743	743	864	864	1092	1092
H - Equalizer Clearance		9	10	10.75	12.75	15.75	16.5	16.5	19.5	19.5	28	28
		229	254	273	324	400	419	419	495	495	711	711
Weight		140	200	480	900	1750	2525	2525	5550	5850	6700	11,200
		64	91	218	408	794	1145	1145	2517	2654	3039	5080

Note: Size 3&4 Butt-weld Class 1500 Flite-Flow Valves are Class 1800. See page 71.

Check Valves

Class 1500 3705 PSI @ 100°F (255.3 BAR @ 38°C)

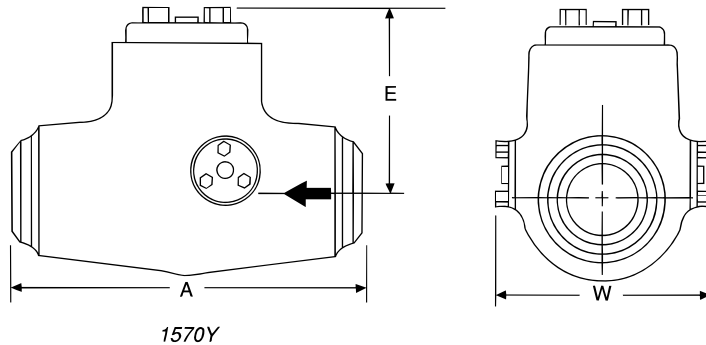
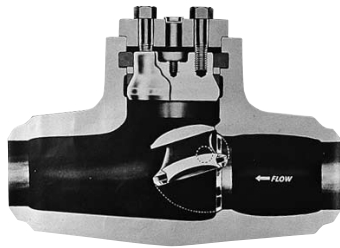

Standard Features

- Bodies and covers are cast steel (WCB, WC6, WC9, C12A, CF8M or CF8C).
- Pressure-seal cover.
- Y-Pattern.
- Integral Stellite seats.
- Body-guided disk piston.

Pressure Class 1500 (PN 260)

Fig. No.		Type	Ends	NPS (DN)
STD CL	SPL CL			
1570Y	2070Y	Tilting Disk	Buttwelding	2½ (65) thru 24 (600)

Dimensions – Tilting Disk

Black numerals are in inches and pounds
Colored numerals are in millimeters and kilograms

Figure No. 1570Y, 2070Y	NPS	2½*	3*	4*	6	8	10
	DN	65	80	100	150	200	250
A - End to End (Welding)		12	12	12	22	28	34
		305	305	305	559	711	864
E - Center to Top		7.25	7.25	7.25	9.25	11	13
		184	184	184	235	279	330
W - Width		10.5	10.5	10.5	16.5	16.75	20.5
		267	267	267	419	425	521
Weight (Welding)		90	90	95	460	600	1005
		41	41	43	209	272	456

* Spiral wound hinge pin gaskets; hinge pin torsion spring not required.

Figure No. 1570Y	NPS	12	14	16	18	20	24
	DN	300	350	400	450	500	600
A - End to End (Welding)		42	40.5	47	53	51.5	58
		1067	1029	1194	1346	1308	1473
E - Center to Top		15.75	15.75	18.75	18.75	23	36
		400	400	476	476	584	914
W - Width		26.5	26.5	29	29	37.5	55
		673	673	737	737	953	1397
Weight (Welding)		1520	1550	3280	3590	4600	10,300
		689	703	1487	1628	2087	4672

Stop Valves

Class 1800 4445 PSI @ 100°F (306.4 BAR @ 38°C)

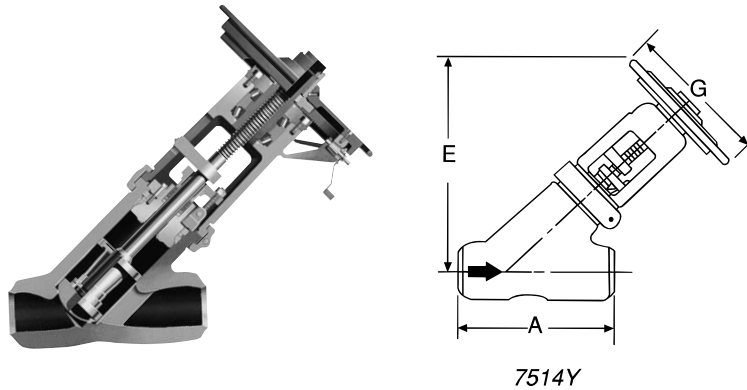

Standard Features

- Bodies and bonnets are cast steel (WCB, WC6, WC9, C12A, CF8M or CF8C).
- Pressure-seal cover, OS & Y.
- Y-Pattern.
- Integral Stellite seats.
- Body-guided disk piston.
- 13% chromium stainless steel stem.

Pressure Class 1800 (PN 310)

Fig. No.		Type	Ends	NPS (DN)
STD CL	SPL CL			
7514Y	2014Y	Flite-Flow	Buttwelding	3 (80) and 4 (100)

Dimensions – Flite-Flow®

Black numerals are in inches and pounds
Colored numerals are in millimeters and kilograms

Figure No. 7514Y, 2014Y	NPS	3	4
	DN	80	100
A - End to End		17	18.5
		432	470
E - Center to Top (Open)		20	25
		508	635
G - Handwheel Diameter*		16	16
		406	406
Weight (Welding)		210	300
		95	136

Stop-Check (Non-Return) Valves Class 1800 4445 PSI @ 100°F (306.4 BAR @ 38°C)

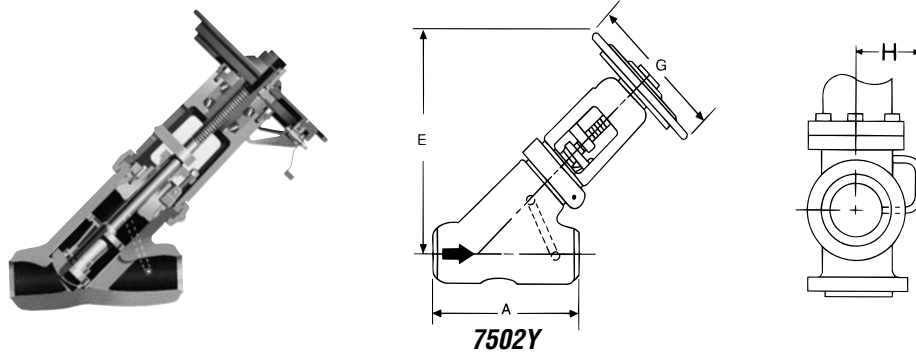

Standard Features

- Bodies and bonnets are cast steel (WCB, WC6, WC9, C12A, CF8M or CF8C).
- Pressure-seal bonnet, OS&Y.
- Y-Pattern.
- Integral Stellite seats.
- Body-guided disk piston.
- Equipped with equalizer.
- 13% chromium stainless steel stem.
- Asbestos-free graphitic packing.

Pressure Class 1800 (PN 310)

Fig. No.		Type	Ends	NPS (DN)
STD CL	SPL CL			
7502Y	2002Y	Flite-Flow	Buttwelding	3 (80) and 4 (100)

Dimensions – Flite-Flow®

Black numerals are in inches and pounds
Colored numerals are in millimeters and kilograms

Figure No. 7502Y, 2002Y	NPS	3	4
	DN	80	100
A - End to End		17	18.5
		432	470
E - Center to Top (Open)		20	25
		508	635
G - Handwheel Diameter*		16	16
		406	406
H - Equalizer Clearance		9	10
		229	254
Weight (Welding)		210	300
		95	136

Check Valves Class 1800 4445 PSI @ 100°F (306.4 BAR @ 38°C)

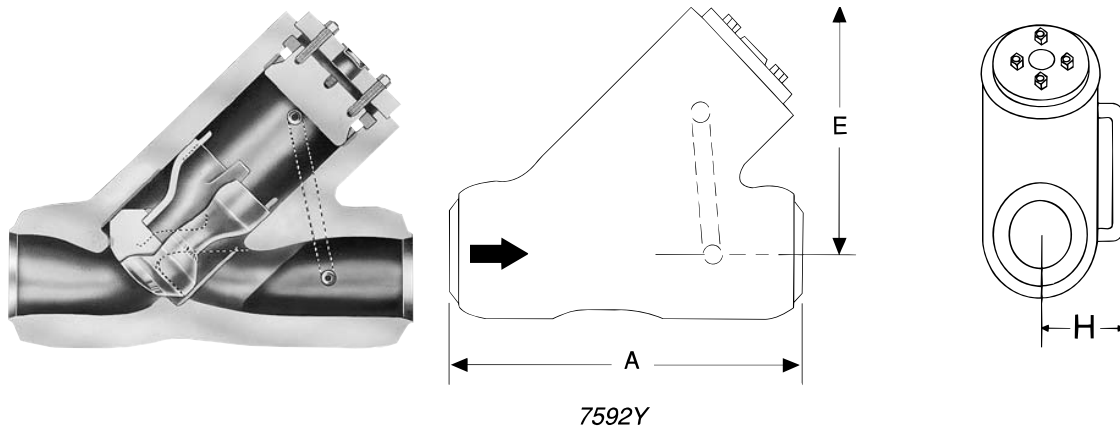

Standard Features

- Bodies and covers are cast steel (WCB, WC6, WC9, C12A, CF8M, or CF8C).
- Pressure-seal cover.
- Y-Pattern.
- Integral Stellite seat and disk.
- Body-guided disk piston.
- Equipped with equalizer.

Pressure Class 1800 (PN 310)

Fig. No.		Type	Ends	NPS (DN)
STD CL	SPL CL			
7592Y	2092Y	Flite-Flow	Buttwelding	3 (80) and 4 (100)

Dimensions – Flite-Flow®

Black numerals are in inches and pounds
Colored numerals are in millimeters and kilograms

Figure No. 7592Y, 2092Y	NPS	3	4
	DN	80	100
A - End to End		17	18.5
		432	470
E - Center to Top (Open)		10	11
		254	279
H - Equalizer Clearance		9	10
		229	254
Weight (Welding)		140	200
		64	91

Stop Valves

Class 2000 4940 PSI @ 100°F (340.4 BAR @ 38°C)

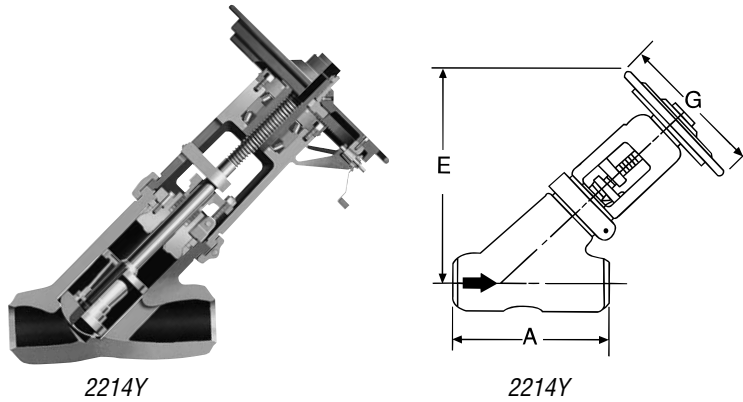

Standard Features

- Bodies and bonnets are cast steel (WCB, WC6, WC9, C12A, CF8M or CF8C).
- Pressure-seal cover, OS & Y.
- Y-Pattern.
- Integral Stellite seat, disk and backseat.
- Body-guided disk piston.
- 13% chromium stainless steel stem.
- Asbestos-free graphitic packing.

Pressure Class 2000 (PN 340)

Fig. No.		Type	Ends	NPS (DN)
STD CL	SPL CL			
2214Y	3214Y	Flite-Flow	Buttwelding	12 (300) and 14 (350)

Dimensions – Flite-Flow®

Black numerals are in inches and pounds
Colored numerals are in millimeters and kilograms

Figure No. 2214Y, 3214Y	NPS	12	14
	DN	300	350
A - End to End		39	39
		991	991
E - Center to Top (Open)		58	58
		1473	1473
G - Handwheel Diameter*		48	48
		1219	1219
Weight (Welding)		4300	4300
		1950	1950

Stop-Check (Non-Return) Valves Class 2000 4940 PSI @ 100°F (340.4 BAR @ 38°C)

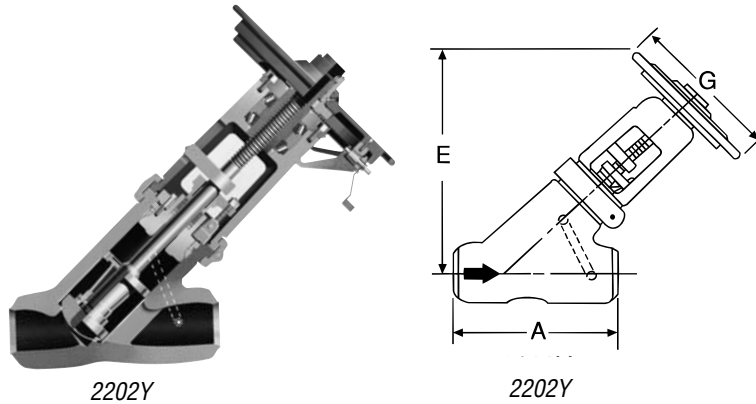

Standard Features

- Bodies and bonnets are cast steel (WCB, WC6, WC9, C12A, CF8M, or CF8C).
- Pressure-seal bonnet, OS & Y.
- Y-Pattern.
- Integral Stellite seat, disk and backseat.
- Body-guided disk piston.
- 13% chromium stainless steel stem.
- Asbestos-free graphitic packing.
- Equipped with equalizer.

Pressure Class 2000 (PN 340)

Fig. No.		Type	Ends	NPS (DN)
STD CL	SPL CL			
2202Y	3202Y	Flite-Flow	Buttwelding	12 (300) and 14 (350)

Dimensions – Flite-Flow®

Black numerals are in inches and pounds
Colored numerals are in millimeters and kilograms

Figure No. 2202Y, 3202Y	NPS	12	14
	DN	300	350
A - End to End		39	39
		991	991
E - Center to Top (Open)		58	58
		1473	1473
G - Handwheel Diameter*		48	48
		1219	1219
H - Equalizer Clearance		18	18
		457	457
Weight		4300	4300
		1950	1950

Check Valves

Class 2000 4940 PSI @ 100°F (340.4 BAR @ 38°C)

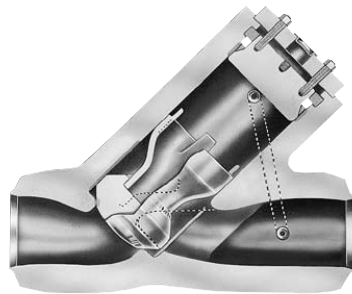

2292Y

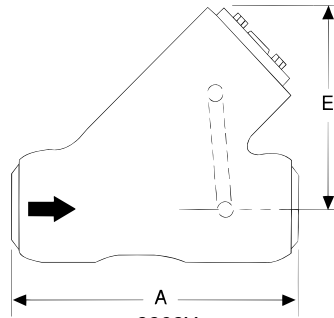

2292Y

Standard Features

- Bodies and covers are cast steel (WCB, WC6, WC9, C12A, CF8M, or CF8C).
- Pressure-seal cover.
- Y-Pattern.
- Integral Stellite seat and disk.
- Body-guided disk piston.
- Equipped with equalizer.

Pressure Class 2000 (PN 340)

Fig. No.		Type	Ends	NPS (DN)
STD CL	SPL CL			
2292Y	3292Y	Flite-Flow	Buttwelding	12 (300) and 14 (350)

Dimensions – Flite-Flow®

Black numerals are in inches and pounds
Colored numerals are in millimeters and kilograms

Figure No. 2292Y, 3292Y	NPS	12	14
	DN	300	350
A - End to End		39	39
		991	991
E - Center to Top		24	24
		610	610
H - Equalizer Clearance		18	18
		457	457
Weight		2900	2900
		1315	1315

Stop Valves

Class 2500 6170 PSI @ 100°F (425.5 BAR @ 38°C)

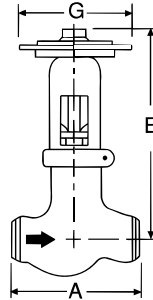
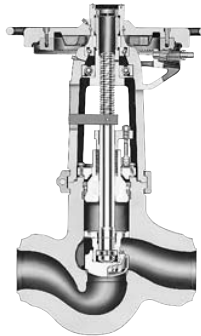

3916Y

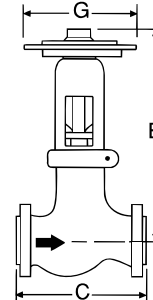

3916

Standard Features

- Bodies and bonnets are cast steel (WCB, WC6, WC9, C12A, CF8M or CF8C).
- Pressure-seal bonnet, OS & Y.
- Vertical, Y-Pattern & angle design.
- Integral Stellite seat, disk and backseat.
- Body-guided disk piston.
- 13% chromium stainless steel stem.
- Asbestos-free graphitic packing.
- Yoke bushing thrust bearings size 5 and larger.

Pressure Class 2500 (PN 420)*

Fig. No.		Type	Ends	NPS (DN)
STD CL	SPL CL			
3914Y	4414Y	Flite-Flow	Buttwelding*	3 (80) thru 24 (600)
3916	—	Globe	Flanged	2½ (65) thru 12 (300)
3916Y	4416Y	Globe	Buttwelding	
3917	—	Angle	Flanged*	2½ (65) thru 24 (600)
3917Y	4417Y	Angle	Buttwelding	

* Flanges to size 12 only.

* Size 3 & 4 Buttweld Flite-Flow Valves are Class 2900. See page 84.

Dimensions - Globe & Angle

Black numerals are in inches and pounds
Colored numerals are in millimeters and kilograms

Figure No. 3916/3916Y, 3917/3917Y, 4416Y/4417Y	NPS	2½	3	4	5	6	8	10	12
	DN	65	80	100	125	150	200	250	300
A1 - End to End, (Welding)		13	15	18	22	24	29	33	38
		330	381	457	559	610	737	838	965
B - Center to End, (Welding)		6.5	7.5	9	11	12	14.5	16.5	19
		165	190	228	279	305	368	419	483
C - Face to Face, (Flanged)		20	22.75	26.5	31.25	36	40.25	50	56
		508	578	673	794	914	1022	1270	1422
D - Center to Face, Flanged		10	11.38	13.25	15.63	18	20.13	25	28
		254	289	337	397	457	511	635	711
E - Center to Top, Globe (Open)		19.63	22.38	25.25	28.25	37.63	47.25	55.25	72.5
		499	568	572	718	955	1200	1403	1842
F - Center to Top, Angle (Open)		18	20	22.5	25	33.75	42.25	48.75	69.5
		457	508	641	635	857	1073	1238	1765
G - Handwheel/Handle Diameter*		14	16	16	20	28	28	36	48
		356	406	406	508	711	711	914	1219
Weight, Globe (Flanged)		158	330	442	890	1586	2370	3160	5050
		72	150	200	404	719	1075	1433	2290
Weight, Globe (Welding)		95	165	255	560	900	1610	2440	3400
		43	75	115	254	408	730	1107	1542
Weight, Angle (Flanged)		150	255	490	830	1466	2120	3320	4650
		68	115	222	376	665	961	1505	2109
Weight, Angle (Welding)		82	148	220	465	780	1450	2110	3000
		37	67	100	211	354	657	957	1360

*Impactor handle is standard on size 2½ Globe and Angle valves.

*Impactor handwheel is standard on all other size Globe, Angle and all Flite-Flow valves.

*Impactogear is available on size 6 and larger valves.

Stop Valves

Class 2500 6170 PSI @ 100°F (425.5 BAR @ 38°C)

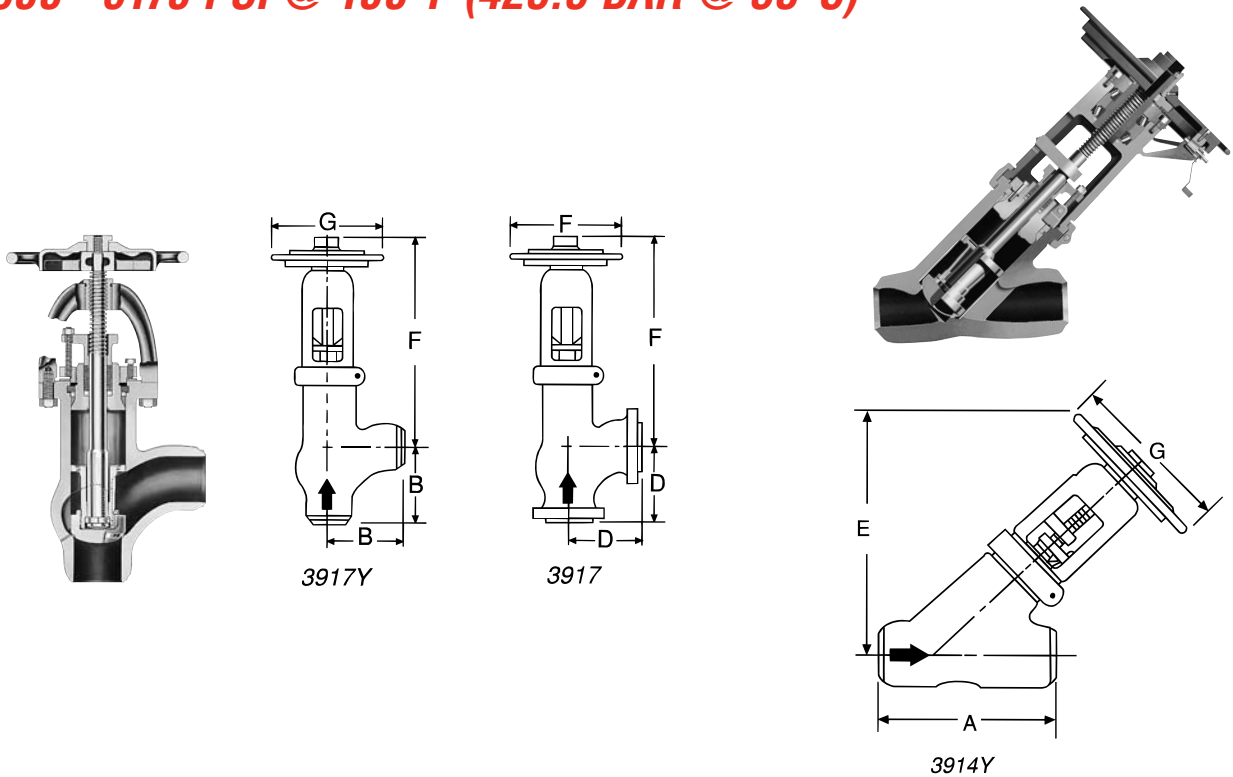

Dimensions – Angle

Black numerals are in inches and pounds
Colored numerals are in millimeters and kilograms

Figure No. 3917/3917Y, 4417Y	NPS	14	16	18	20	22	24
	DN	350	400	450	500	550	600
B - Center to End (Welding)		20.25	20.25	23.5	23.5	26	28.5
		514	514	597	597	660	724
F - Center to Top, Angle (Open)		67	67	92	92	89.5	96
		1701	1701	2300	2300	2238	2438
G - Handwheel Diameter*		48	48	72	72	72	72
		1219	1219	1829	1829	1829	1829
Weight, Angle (Welding)		5350	5410	10,460	10,540	14,350	18,200
		2427	2454	4745	4781	6509	8255

Dimensions – Flite-Flow

Figure No. 3914Y, 4414Y	NPS	3	4	6	8	10	12	14	16	18	20	24
	DN	80	100	150	200	250	300	350	400	450	500	600
A - End to End (Welding)		17	18.5	24	30	36	41	48.75	48.75	58	58	68
		432	470	610	762	914	1041	1238	1238	1473	1473	1727
E - Center to Top (Open)		20	25	37.5	41.75	50	65	69	69	93.8	93.8	113
		508	635	953	1060	1270	1651	1753	1753	2382	2382	2870
G - Handwheel Diameter*		16	16	28	28	36	48	48	48	72	72	72
		406	406	711	711	914	1219	1219	1219	1829	1829	1829
Weight (Welding)		230	325	875	1610	2750	4600	6990	7010	12,700	12,790	16,570
		104	147	397	730	1247	2087	3171	3180	5761	5802	7516

*Impactor handle is standard on size 2-½ Globe and Angle valves.

*Impactor handwheel is standard on all other size Globe, Angle and all Flite-Flow valves.

*Impactogear is available on size 6 and larger valves.

Note: Size 3&4 Butt-weld Class 2500 Flite-Flow Valves are Class 2900. See page 84.

Stop Valves

Class 2500 6170 PSI @ 100°F (425.5 BAR @ 38°C)

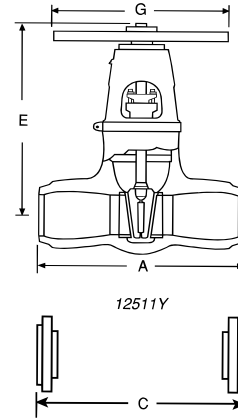

Standard Features

- Bodies and bonnets are cast steel (WCB, WC6, WC9, C12A, CF8M or CF8C).
- Pressure-seal bonnet, OS & Y.
- Integral Stellite seat and backseat.
- Two-piece body-guided wedge.
- 13% chromium stainless steel stem.
- Asbestos-free graphitic packing.
- Available in standard or venturi pattern.
- Yoke bushing thrust bearings.

Pressure Class 2500 (PN 420)

Fig. No.		Type	Ends	NPS (DN)
STD CL	SPL CL			
12511	—	Equiwedge Gate	Flanged*	2-½ (65) thru 24 (600)
12511Y	14411Y	Equiwedge Gate	Buttwelding	
12511BY	14411BY	Venturi Pattern Equiwedge Gate	Buttwelding	8 (200) thru 28 (700)

Dimensions – Equiwedge Gate

Black numerals are in inches and pounds
Colored numerals are in millimeters and kilograms

Figure No. 12511/12511Y, 14411Y	NPS	2-½	3	4	6	8	10	12
	DN	65	80	100	150	200	250	300
A - End to End (Welding)		13	14.5	18	24	30	36	41
		330	368	457	610	762	914	1041
C - Face to Face (Flanged)		20	22.75	26.5	36	40.25	50	56
		508	578	673	914	1022	1270	1422
E - Center to Top (Open)		21.5	21.5	22	31.75	36.75	49.25	56
		546	546	559	806	933	1251	1422
G - Handwheel/Handle Diameter		24	24	24	30	36	36	48
		610	610	610	762	914	914	1219
Weight (Welding)		126	126	318	715	1245	2130	3557
		57	57	144	324	565	966	1613

Figure No. 12511/12511Y, 14411Y	NPS	14	16	18	20	22	24
	DN	350	400	450	500	550	600
A - End to End (Welding)		44	49	55	62	64	66
		1118	1245	1397	1575	1626	1676
C - Face to Face (Flanged)		N/A					
E - Center to Top (Open)		56.75	66	71	75.5	87.25	88.75
		1441	1676	1803	1918	2116	2254
G - Handwheel Diameter		48	48	60	60	72	72
		1219	1219	1524	1524	1829	1829
Weight (Welding)		5167	6600	8600	11,400	13,000	15,000
		2349	2994	3901	5171	5897	6804

Stop Valves

Class 2500 6170 PSI @ 100°F (425.5 BAR @ 38°C)

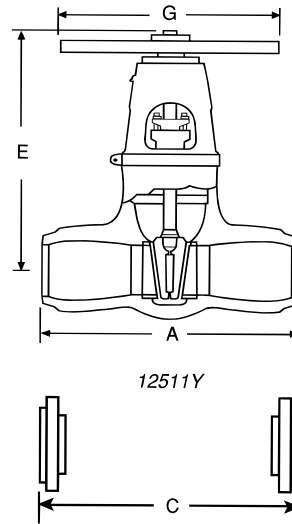

Dimensions – Equiwedge Gate Venturi Pattern

Black numerals are in inches and pounds
Colored numerals are in millimeters and kilograms

Figure No. 12511BY/14411BY	NPS	8x6x8	10x8x10	12x10x12	14x12x14	16x14x16
	DN	200	250	300	350	400
A - End to End (Welding)		24	30	36	41	44
		610	762	914	1041	1118
E - Center to Top (Open)		31.75	36.75	49.25	56	56.75
		806	933	1251	1422	1441
G - Handwheel Diameter		30	36	36	48	48
		762	914	914	1219	1219
Weight (Welding)		715	1245	2165	3557	5167
		325	566	984	1617	2349

Figure No. 12511BY/14411BY	NPS	18x16x18	20x18x20	22x20x22	24x20x24	26x22x26	28x24x28
	DN	450	500	550	600	650	700
A - End to End (Welding)		49	55	62	62	64	66
		1245	1397	1575	1575	1626	1676
E - Center to Top (Open)		66	71	75.5	75.5	87.25	88.75
		1676	1803	1918	1918	2116	2254
G - Handwheel Diameter		48	60	60	60	72	72
		1219	1524	1524	1524	1829	1829
Weight (Welding)		6600	8600	11,400	13,000	15,000	15,000
		2994	3901	5171	5900	6800	6800

Stop-Check (Non-Return) Valves

Class 2500 6170 PSI @ 100°F (425.5 BAR @ 38°C)

Standard Features

- Bodies and bonnets are cast steel (WCB, WC6, WC9, C12A, CF8M or CF8C).
- Pressure-seal bonnet, OS & Y.
- Y-Pattern, globe & angle design.
- Integral Stellite seat, disk and backseat.
- Body-guided disk piston.
- 13% chromium stainless steel stem.
- Asbestos-free graphitic packing.
- Equipped with equalizer.
- Yoke bushing thrust bearings size 5 and larger.

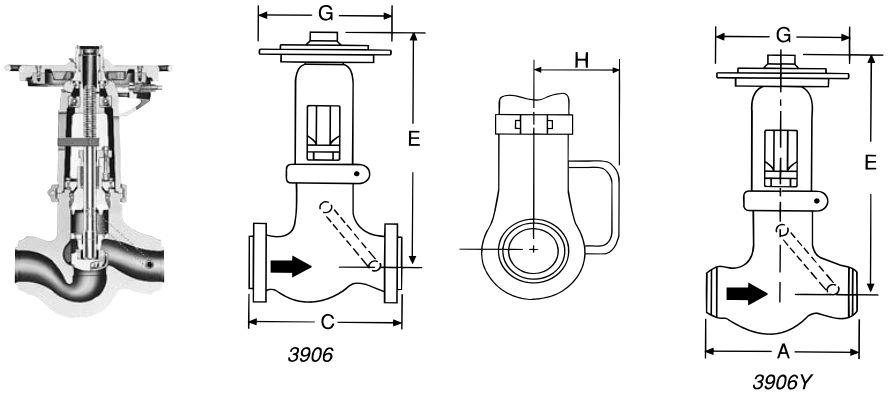

Pressure Class 2500 (PN 420)*

Fig. No.		Type	Ends	NPS (DN)
STD CL	SPL CL			
3902Y	4402Y	Flite-Flow	Buttwelding*	3 (80) thru 24 (600)
3906	—	Globe	Flanged	2-½ (65) thru 12 (300)
3906Y	4406Y	Globe	Buttwelding	
3907	—	Angle	Flanged*	2-½ (65) thru 24 (600)
3907Y	4407Y	Angle	Buttwelding	

* Flanges to size 12 only.

* Size 3 & 4 Buttweld Flite-Flow Valves are Class 2900. See page 85.

Dimensions – Globe & Angle

Black numerals are in inches and pounds
Colored numerals are in millimeters and kilograms

Figure No. 3906/3906Y, 3907/3907Y, 4406Y, 4407Y	NPS DN	2-½	3	4	5	6	8	10	12
A - End to End (Welding)	13	15	18	22	24	29	33	38	
	330	381	457	559	610	737	838	965	
B - Center to End (Welding)	6.5	7.5	9	11	12	14.5	16.5	19	
	165	190	229	279	305	368	419	483	
C - Face to Face, (Flanged)	20	22.75	26.5	31.25	36	40.25	50	56	
	508	578	673	794	914	1022	1270	1422	
D - Center to Face (Flanged)	10	11.38	13.25	15.63	18	20.13	25	28	
	254	289	337	397	457	511	635	711	
E - Center to Top, Globe	19.63	22.38	25.25	28.25	37.63	47.25	55.25	72.5	
	499	568	641	718	956	1200	1403	1842	
F - Center to Top, Angle	18	20	22.5	25	33.75	42.25	48.75	69.5	
	457	508	572	635	857	1073	1238	1765	
G - Handwheel/Handle Diameter*	14	16	16	20	28	28	36	48	
	356	406	406	508	711	711	914	1219	
H - Clearance for Equalizer	7.25	8	8.5	8.5	11	11.5	14	16	
	184	203	216	216	279	292	356	406	
Weight, Globe (Flanged)	160	350	520	900	1600	2400	3200	5100	
	73	159	236	408	726	1089	1452	2313	
Weight, Globe (Welding)	95	169	263	570	915	1730	2480	3450	
	43	77	119	259	415	785	1125	1565	
Weight, Angle (Flanged)	152	260	420	840	1480	2150	3360	4700	
	69	118	191	381	671	975	1524	2132	
Weight, Angle (Welding)	84	150	228	475	795	1480	2140	3050	
	38	68	103	215	361	671	971	1383	

*Impactor handle is standard on size 2-½ Globe and Angle valves.

*Impactor handwheel is standard on all other size Globe, Angle and all Flite-Flow valves.

*Impactogear is available on size 6 and larger valves.

Stop-Check (Non-Return) Valves

Class 2500 6170 PSI @ 100°F (425.5 BAR @ 38°C)

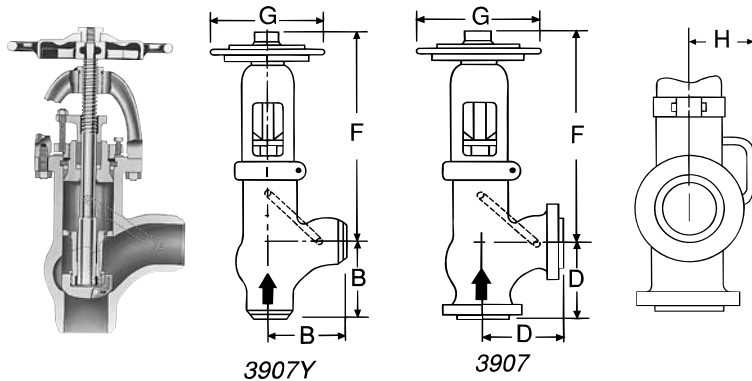
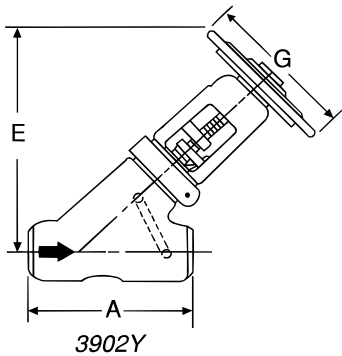
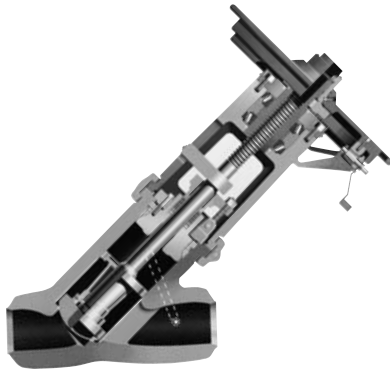

Dimensions – Angle

Black numerals are in inches and pounds
Colored numerals are in millimeters and kilograms

Figure No. 3907/3907Y, 4407Y	NPS	14	16	18	20	22	24
	DN	350	400	450	500	550	600
B - Center to End (Welding)		20.25	20.25	23.5	23.5	26	28.5
		514	514	597	597	660	724
F - Center to Top, Angle		67	67	92	92	89.5	96
		1702	1702	2337	2337	2273	2438
G - Handwheel Diameter*		48	48	72	72	72	72
		1219	1219	1829	1829	1829	1829
H - Clearance for Equalizer		18.5	18.5	22	22	23	24
		470	470	559	559	584	610
Weight, Angle (Welding)		5390	5450	10,540	10,620	14,470	18,340
		2445	2472	4781	4817	6564	8319

Dimensions – Flite-Flow

Figure No. 3902Y, 4402Y	NPS	3	4	6	8	10	12	14	16	18	20	24
	DN	80	100	150	200	250	300	350	400	450	500	600
A - End to End (Welding)		17	18.5	24	30	36	41	48.75	48.75	58	58	68
		432	470	610	762	914	1041	1238	1238	1473	1473	1727
E - Center to Top		20	25	37.5	41.75	50	65	69	69	93.8	93.8	113
		508	635	953	1060	1290	1651	1753	1753	2383	2383	2870
G - Handwheel Diameter*		16	16	28	28	36	48	48	48	72	72	72
		408	406	711	711	914	1219	1219	1219	1829	1829	1829
H - Equalizer Clearance		9	10	11	11.5	15.75	17.5	20.25	20.25	23.5	23.5	32
		229	254	279	292	400	445	514	514	591	591	813
Weight (Welding)		230	325	890	1610	2750	4600	6990	7010	12,700	12,790	16,570
		104	147	404	730	1247	2087	3170	3179	5760	5802	7516

* Impactor handwheel is standard on all valves.

* Impactogear is available on size 6 and larger valves.

Note: Size 3&4 Butt weld Class 2500 Flite-Flow Valves are Class 2900. See page 85.

Check Valves

Class 2500 6170 PSI @ 100°F (425.5 BAR @ 38°C)

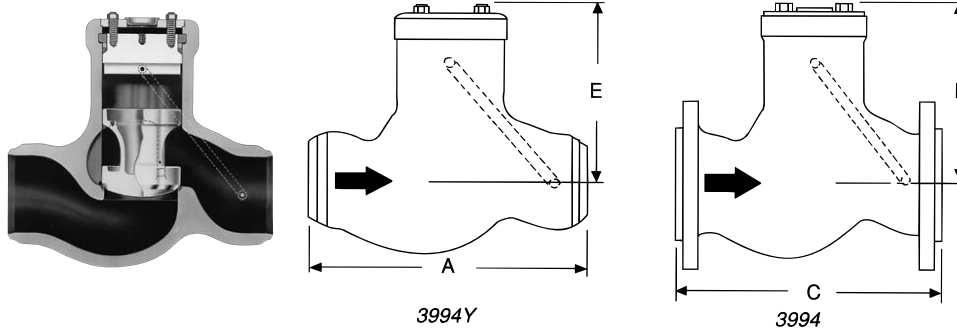

Standard Features

- Bodies and covers are cast steel (WCB, WC6, WC9, C12A, CF8M or CF8C).
- Pressure-seal cover.
- Integral Stellite seats.
- Body-guided disk piston.
- Equipped with equalizer.

Pressure Class 2500 (PN 420)*

Fig. No.		Type	Ends	NPS (DN)
STD CL	SPL CL			
3992Y	4492Y	Flite-Flow	Buttwelding*	3 (80) thru 24 (600)
3994	—	Globe	Flanged	2-½ (65) thru 12 (300)
3994Y	4494Y	Globe	Buttwelding	
3995	—	Angle	Flanged*	2-½ (65) thru 24 (600)
3995Y	4495Y	Angle	Buttwelding	
2570Y	4470Y	Tilting Disk	Buttwelding	2-½ (65) thru 24 (600)

*Flanges to size 12 only.

*Size 3&4 Buttweld Flite-Flow Valves are Class 2900. See page 86.

Dimensions – Globe & Angle

Black numerals are in inches and pounds
Colored numerals are in millimeters and kilograms

Figure No. 3994/3994Y, 3995/3995Y, 4494Y, 4495Y	NPS	2-½	3	4	5	6	8	10	12
	DN	65	80	100	125	150	200	250	300
A - End to End (Welding)		13	15	18	22	24	29	33	38
		330	381	457	559	610	737	838	965
B - Center to End (Welding)		6.5	7.5	9	11	12	14.5	16.5	19
		165	190	229	279	305	368	419	483
C - Face to Face (Flanged)		20	22.75	26.5	31.25	36	40.5	50	56
		508	578	673	794	914	1022	1270	1422
D - Center to Face (Flanged)		10	11.38	13.25	15.63	18	20.13	25	28
		254	289	337	397	457	511	635	711
E - Center to Top, Globe		9.25	10.38	11.25	12.25	14	17	19.25	23
		235	264	286	311	356	432	489	584
F - Center to top, Angle		7.63	8.38	8.5	9	10.25	12	12.75	20
		194	213	216	229	260	305	324	508
H - Clearance for Equalizer		7.25	8	8.5	8.5	11	11.5	14	16
		184	203	216	216	279	292	356	406
Weight, Globe (Flanged)		120	200	290	670	900	1760	2920	4070
		54	91	131	304	408	798	1324	1846
Weight, Globe (Welding)		65	108	185	318	490	1010	1690	2420
		29	49	84	144	222	458	766	1098
Weight, Angle (Flanged)		112	185	275	610	820	1610	2520	3860
		51	84	124	277	372	730	1143	1751
Weight, Angle (Welding)		57	92	155	263	372	827	1284	2210
		26	42	70	119	169	375	582	1002

Check Valves

Class 2500 6170 PSI @ 100°F (425.5 BAR @ 38°C)

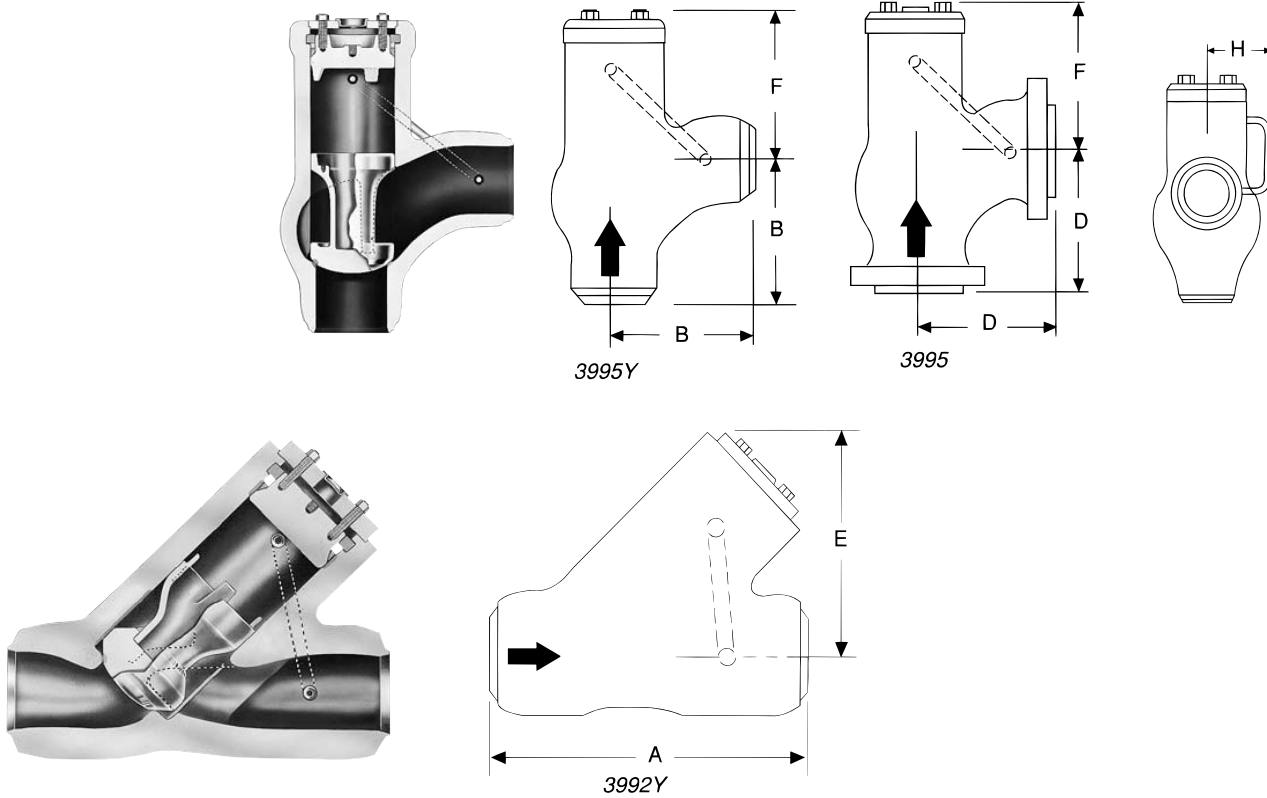

Dimensions – Angle

Black numerals are in inches and pounds
Colored numerals are in millimeters and kilograms

Figure No. 3995/3995Y, 4495Y	NPS	14	16	18	20	22	24
	DN	350	400	450	500	550	600
B - Center to End (Welding)		20.25	20.25	23.5	23.5	26	28.5
		514	514	597	597	660	724
F - Center to Top, Angle		21.75	21.75	26.5	26.5	30.5	33
		552	552	673	673	775	838
H - Clearance for Equalizer		18.5	18.5	22	22	23	24
		470	470	559	559	584	610
Weight, Angle (Welding)		3210	3270	5570	5650	8100	10,550
		1456	1483	2527	2562	3674	4785

Dimensions – Flite-Flow

Figure No. 3992Y, 4492Y	NPS	3	4	6	8	10	12	14	16	18	20	24
	DN	80	100	150	200	250	300	350	400	450	500	600
A - End to End (Welding)		17	18.5	24	30	36	41	48.75	48.75	58	58	68
		432	470	610	762	914	1041	1238	1238	1473	1473	1727
E - Center to Top		10	11	14.25	18.75	22.25	26.75	28.5	28.5	36.5	36.5	54
		254	279	362	476	565	679	724	724	927	927	1372
H - Equalizer Clearance		9	10	11	11.5	15.75	17.5	20.25	20.25	23.5	23.5	32
		229	254	279	292	400	445	514	514	591	591	813
Weight (Welding)		150	225	510	950	1950	2730	4300	4300	8100	8190	12,620
		68	102	230	431	884	1238	1950	1950	3674	3715	5724

Check Valves Class 2500 6170 PSI @ 100°F (425.5 BAR @ 38°C)

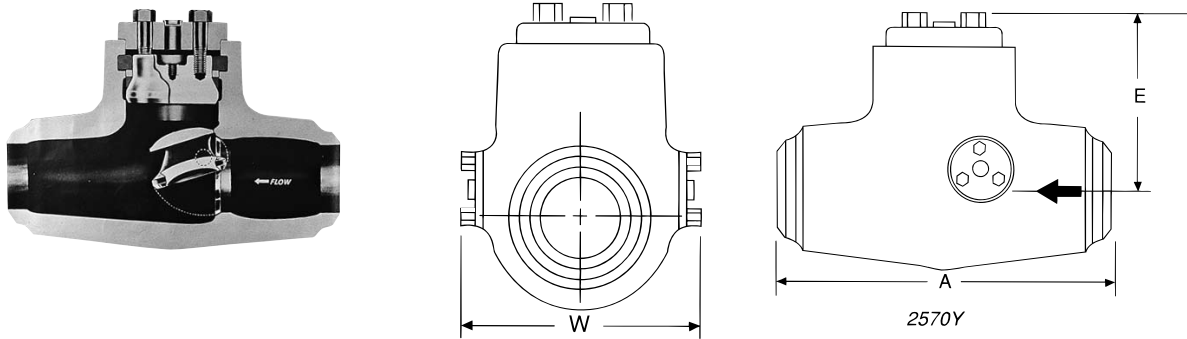

Standard Features

- Bodies and covers are cast steel (WCB, WC6, WC9, C12A, CF8M or CF8C).
- Pressure-seal cover.
- Integral Stellite seats.

Dimensions – Tilting Disk

Black numerals are in inches and pounds
Colored numerals are in millimeters and kilograms

Figure No. 2570Y, 4470Y	NPS	2-½*	3*	4*	6	8	10
	DN	65	80	100	150	200	250
A - End to End (Welding)		12	12	12	24	30	36
		305	305	305	610	762	914
E - Center to Top		7.25	7.25	7.25	9.5	10.5	12.5
		184	184	184	241	267	318
W - Width		10.5	10.5	10.5	15	18	20
		267	267	267	381	457	508
Weight (Welding)		95	95	95	435	800	1180
		43	43	43	197	363	535

*Spiral wound hinge pin gaskets; hinge pin torsion spring not required.

Figure No. 2570Y, 4470Y	NPS	12	14	16	18	20	24
	DN	300	350	400	450	500	600
A - End to End (Welding)		41	44	44	55	55	63
		1041	1118	1118	1397	1397	1600
E - Center to Top		15.75	17.75	17.75	23.75	23.75	31
		400	451	451	603	603	787
W - Width		24.25	28.5	28.5	35	35	45
		616	724	724	889	889	1143
Weight (Welding)		2250	3200	3200	5580	5690	13,200
		1021	1452	1452	2531	2581	5988

Stop Valves

Class 2900 7160 PSI @ 100°F (493.6 BAR @ 38°C)

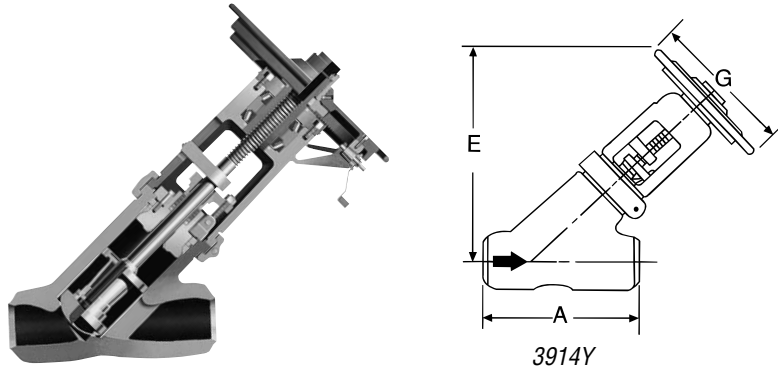

Standard Features

- Bodies and bonnets are cast steel (WCB, WC6, WC9, C12A, CF8M, or CF8C).
- Pressure-seal bonnet, OS & Y.
- Y-Pattern.
- Integral Stellite seat, disk and backseat.
- Body-guided disk piston.
- 13% chromium stainless steel stem.
- Asbestos-free graphitic packing.

Pressure Class 2900 (PN 490)

Fig. No.		Type	Ends	NPS (DN)
STD CL	SPL CL			
3914Y	4414Y	Flite-Flow	Buttwelding	3 (80) and 4 (100)

Dimensions – Flite-Flow®

Black numerals are in inches and pounds
Colored numerals are in millimeters and kilograms

Figure No. 3914Y, 4414Y	NPS	3	4
	DN	80	100
A - End to End		17	18.5
		432	470
E - Center to Top (Open)		20	25
		508	635
G - Handwheel Diameter		16	16
		406	406
Weight		230	325
		104	147

Stop-Check (Non-Return) Valves Class 2900 7160 PSI @ 100°F (493.6 BAR @ 38°C)

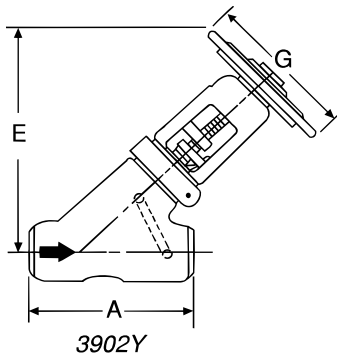

Standard Features

- Bodies and bonnets are cast steel (WCB, WC6, WC9, C12A, CF8M, or CF8C).
- Pressure-seal bonnet, OS & Y.
- Y-Pattern.
- Integral Stellite seat, disk and backseat.
- Body-guided disk piston.
- 13% chromium stainless steel stem.
- Asbestos-free graphitic packing.
- Equipped with equalizer.

Pressure Class 2900 (PN 490)

Fig. No.		Type	Ends	NPS (DN)
STD CL	SPL CL			
3902Y	4402Y	Flite-Flow	Buttwelding	3 (80) and 4 (100)

Dimensions – Flite-Flow®

Black numerals are in inches and pounds
Colored numerals are in millimeters and kilograms

Figure No. 3902Y, 4402Y	NPS	3	4
	DN	80	100
A - End to End		17	18.5
		432	470
E - Center to Top (Open)		20	25
		508	635
G - Handwheel Diameter*		16	16
		406	406
H - Equalizer Clearance		9	10
		229	254
Weight		230	325
		104	147

Check Valves

Class 2900 7160 PSI @ 100°F (493.6 BAR @ 38°C)

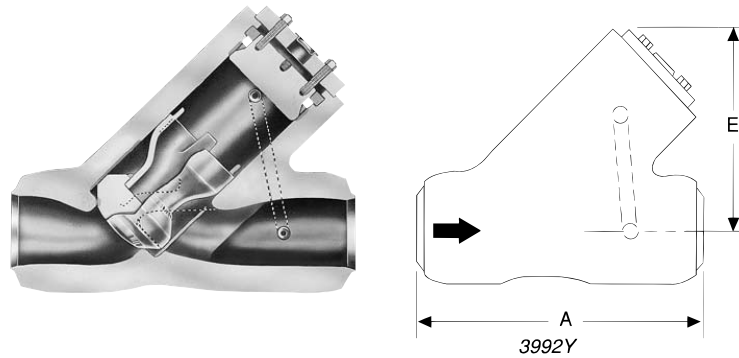

Standard Features

- Bodies and covers are cast steel (WCB, WC6, WC9, C12A, CF8M, or CF8C).
- Pressure-seal cover.
- Y-Pattern.
- Integral Stellite seat and disk.
- Body-guided disk piston.
- Equipped with equalizer.

Pressure Class 2900 (PN 490)

Fig. No.		Type	Ends	NPS (DN)
STD CL	SPL CL			
3992Y	4492Y	Flite-Flow	Buttwelding	3 (80) and 4 (100)

Dimensions – Flite-Flow®

Black numerals are in inches and pounds
Colored numerals are in millimeters and kilograms

Figure No. 3992Y, 4492Y	NPS	3	4
	DN	80	100
A - End to End		17	18.5
		432	470
E - Center to Top		10	11
		254	279
H - Equalizer Clearance		9	10
		229	254
Weight		150	225
		68	102

Stop Valves

Class 3600 8885 PSI @ 100°F (612.7 BAR @ 38°C)

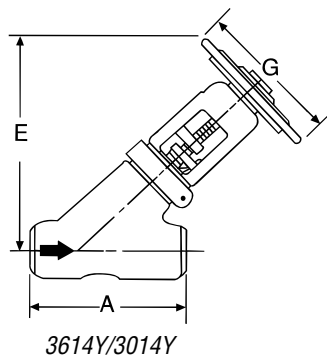

Standard Features

- Bodies and bonnets are cast steel (WCB, WC6, WC9, C12A, CF8M or CF8C).
- Pressure-seal bonnet, OS & Y.
- Y-Pattern.
- Integral Stellite seats and backseat.
- Body-guided disk piston.
- 13% chromium stainless steel stem.
- Yoke bushing thrust bearings.

Dimensions – Flite-Flow**

Figure No.**	NPS	16	18	20	24
A - End to End (Welding)					
E - Center to Top					
G - Handwheel Diameter*					
Weight (Welding)					

* Impactor handwheel is standard on all valves.

* Impactogear is available on size 6 and larger valves.

** Consult Flowserve sales representative for figure numbers and applicable dimensions.

Stop Valves

Class 3600 8885 PSI @ 100°F (612.7 BAR @ 38°C)

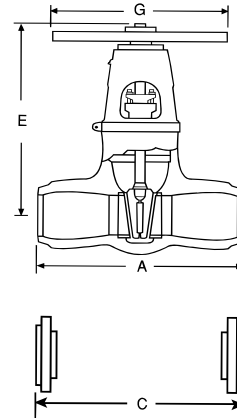

Standard Features

- Bodies and bonnets are cast steel (WCB, WC6, WC9, C12A, CF8M or CF8C).
- Pressure-seal bonnet, OS & Y.
- Integral Stellite seat and backseat.
- Two-piece body-guided wedge.
- 13% chromium stainless steel stem.
- Asbestos-free graphitic packing.
- Available in standard or venturi pattern.
- Yoke bushing thrust bearings.

Pressure Class 3600

Fig. No.		Type	Ends	NPS (DN)
STD CL	SPL CL			
13611Y	13011Y	Equiwedge Gate	Buttwelding	16 (400) thru 24 (600)
13611BY	13011BY	Venturi Pattern Equiwedge Gate	Buttwelding	18 (450) thru 28 (700)

Dimensions – Equiwedge Gate*

Figure No.*	NPS	16	18	20	22	24
A - End to End (Welding)						
E - Center to Top (Open)						
G - Handwheel Diameter						
Weight (Welding)						

* Consult Flowserve sales representative for applicable dimensions.

Stop Valves
Class 3600 8885 PSI @ 100°F (612.7 BAR @ 38°C)

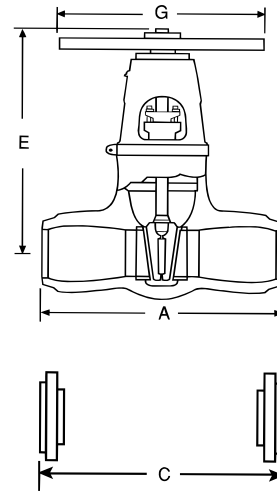

Dimensions – Equiwedge Gate*
Venturi Pattern

Figure No.*	NPS	18x16x18	20x18x20	22x20x22	24x20x24	26x22x26	28x24x28
A - End to End (Welding)							
E - Center to Top (Open)							
G - Handwheel Diameter							
Weight (Welding)							

* Consult Flowserve sales representative for figure numbers and applicable dimensions.

Stop-Check (Non-Return) Valves

Class 3600 8885 PSI @ 100°F (612.7 BAR @ 38°C)

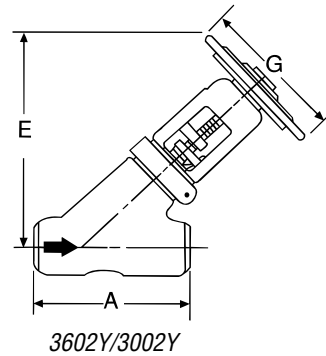
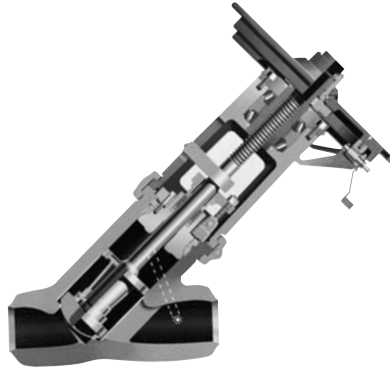

Standard Features

- Bodies and bonnets are cast steel (WCB, WC6, WC9, C12A, CF8M or CF8C).
- Pressure-seal bonnet, OS & Y.
- Y-Pattern.
- Integral Stellite seats and backseats.
- Body-guided disk piston.
- 13% chromium stainless steel stem.
- Asbestos-free graphitic packing.
- Equipped with equalizer.
- Yoke bushing thrust bearings.

Dimensions – Flite-Flow**

Figure No.**	NPS	16	18	20	24
A - End to End (Welding)					
E - Center to Top					
G - Handwheel Diameter*					
H - Equalizer Clearance					
Weight (Welding)					

* Impactor handwheel is standard on all valves.

* Impactogear is available on size 6 and larger valves.

** Consult Flowserve sales representative for figure numbers and applicable dimensions.

Check Valves

Class 3600 8885 PSI @ 100°F (612.7 BAR @ 38°C)

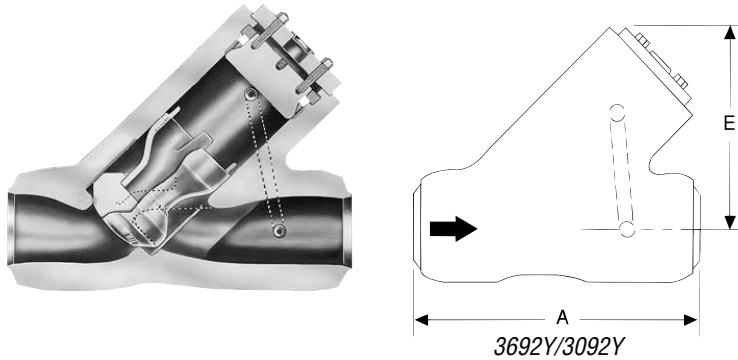

Standard Features

- Bodies and covers are cast steel (WCB, WC6, WC9, C12A, CF8M or CF8C).
- Pressure-seal cover.
- Y-Pattern design.
- Integral Stellite seats.
- Body-guided disk piston.
- Equipped with Equalizer.

Dimensions – Flite-Flow®

Black numerals are in inches and pounds
Colored numerals are in millimeters and kilograms

Figure No. 3602Y	NPS	16	18	20	24
A - End to End					
E - Center to Top					
H - Equalizer Clearance					
Weight					

** Consult Flowsolve sales representative for figure numbers and applicable dimensions.

Stop Valves Series 4500

These Series 4500 valves are designed and rated to Edward Valve standards. See section 3.2 for additional information.

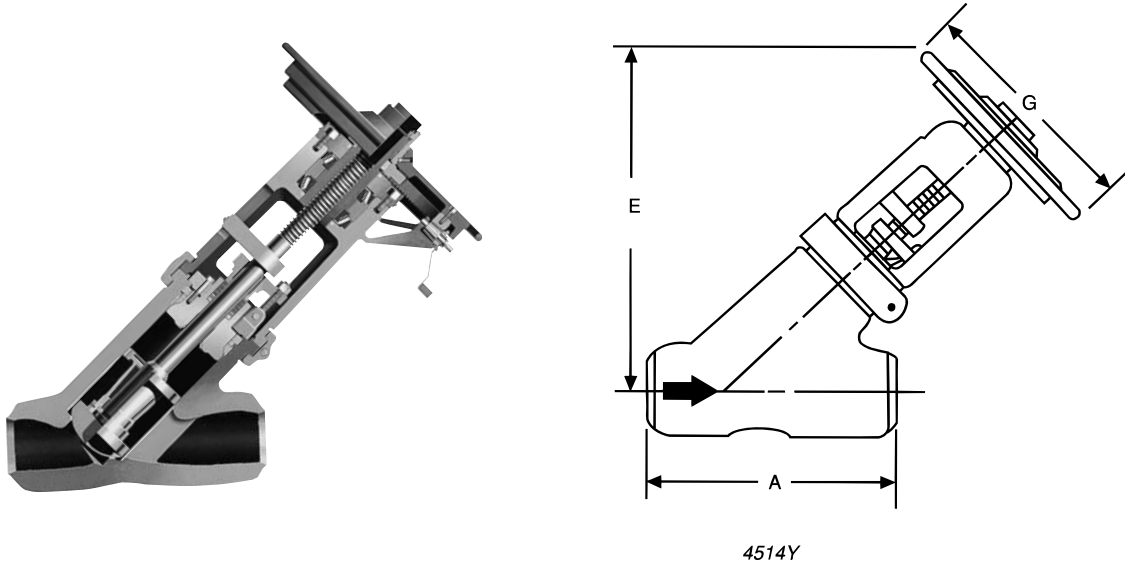

Standard Features

- Bodies and bonnets are cast steel (WCB, WC6, WC9, C12A, CF8M or CF8C).
- Pressure-seal bonnet, OS & Y.
- Y-Pattern.
- Integral Stellite seats and backseat.
- Body-guided disk piston.
- 13% chromium stainless steel stem.
- Yoke bushing thrust bearings.

Series 4500

Fig. No.		Type	Ends	NPS (DN)
STD Series	SPL Series			
4514Y	5014Y	Flite-Flow	Buttwelding	4 (100) thru 10 (250)

Dimensions – Flite-Flow

Black numerals are in inches and pounds
Colored numerals are in millimeters and kilograms

Figure No. 4514Y, 5014Y	NPS	4	6	8	10
	DN		100	150	200
A - End to End		28	31	31	39.75
		711	787	787	1010
E - Center to Top (Open)		27.4	35	48.25	52.75
		696	889	1226	1340
G - Handwheel Diameter*		20	28	36	36
		508	711	914	914
Weight		625	1360	2510	4020
		284	617	1139	1823

* Impactor handwheel is standard on size 4 & larger. Impactogear is available on size 6 and larger.

Stop Check (Non-Return) Valves Series 4500

These Series 4500 valves are designed and rated to Edward Valve standards. See section 3.2 for additional information.

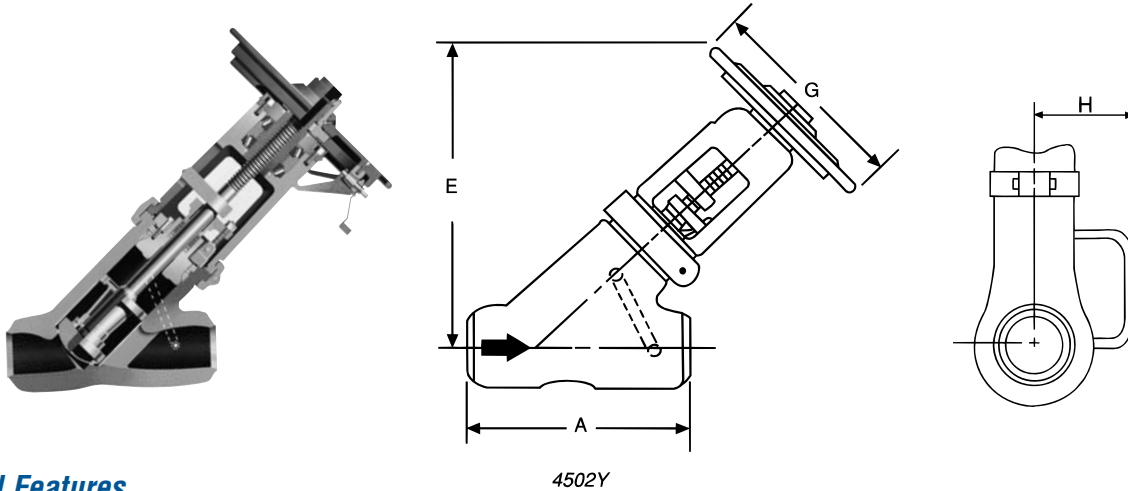

Standard Features

- Bodies and bonnets are cast steel (WCB, WC6, WC9, C12A, CF8M or CF8C).
- Pressure-seal bonnet, OS & Y.
- Y-Pattern.
- Integral Stellite seats and backseats.
- Body-guided disk piston.
- 13% chromium stainless steel stem.
- Asbestos-free graphitic packing.
- Equipped with equalizer.
- Yoke bushing thrust bearings.

Series 4500

Fig. No.		Type	Ends	NPS (DN)
STD Series	SPL Series			
4502Y	5002Y	Flite-Flow	Buttwelding	4 (100) thru 10 (250)

Dimensions – Flite Flow

Black numerals are in inches and pounds
Colored numerals are in millimeters and kilograms

Figure No. 4502Y/5002Y	NPS	4	6	8	10
	DN	100	150	200	250
A - End to End		28	31	31	39.75
		711	787	787	1010
E - Center to Top		27.4	35	48.25	52.75
		695	889	1226	1340
G - Handwheel Diameter*		20	28	36	36
		508	711	914	914
H - Equalizer Clearance		9.75	10.6	14.5	18.5
		248	270	368	470
Weight		625	1360	2510	4020
		284	617	1139	1823

*Impactor handwheel is standard on size 4 & larger. Impactogear is available on size 6 and larger.

Check Valves Series 4500

These Series 4500 valves are designed and rated to Edward Valve standards. See 3.2 Pressure Ratings in the Technical Information Section for additional information.

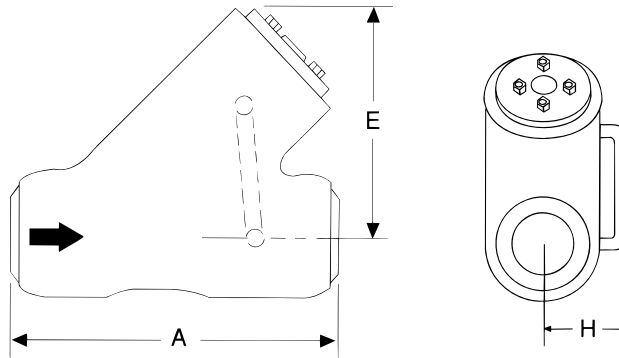
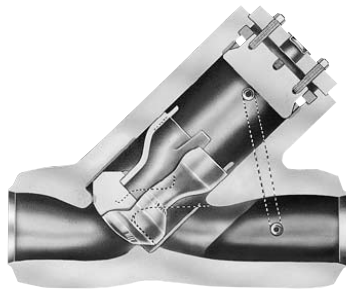

4592Y

Standard Features

- Bodies and covers are cast steel (WCB, WC6, WC9, C12A, CF8M or CF8C).
- Pressure-seal cover.
- Y-Pattern design.
- Integral Stellite seats.
- Body-guided disk piston.
- Equipped with Equalizer.

Series 4500

Fig. No.		Type	Ends	NPS (DN)
STD Series	SPL Series			
4592Y	5092Y	Flite-Flow	Buttwelding	4 (100) thru 10 (250)

Dimensions – Flite Flow

Black numerals are in inches and pounds
Colored numerals are in millimeters and kilograms

Figure No. 4592Y/5092Y	NPS	4	6	8	10
	DN	100	150	200	250
A - End to End		28	31	31	39.75
		711	787	787	1010
E - Center to Top		14	18	20	26
		356	457	508	660
H - Equalizer Clearance		9.75	10.6	14.5	18.5
		248	269	368	470
Weight		415	800	1500	2300
		188	360	675	1035

Check Valves

Class 4500 11,110 PSI @ 100°F (765.9 BAR @ 38°C)

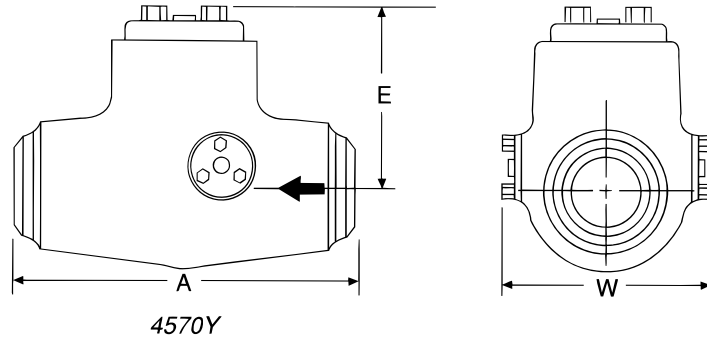
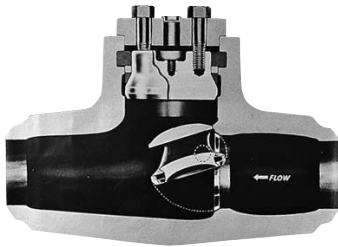

Standard Features

- Bodies and covers are cast steel (WCB, WC6, WC9, C12A, CF8M or CF8C).
- Pressure-seal cover.
- Tilting Disk design.
- Integral Stellite seats.

Class 4500 (PN 760)

Fig. No.		Type	Ends	NPS (DN)
STD CL	SPL CL			
4570Y	5070Y	Tilting Disk	Buttwelding	6 (150) and 8 (200)

Dimensions – Tilting Disk

Black numerals are in inches and pounds
Colored numerals are in millimeters and kilograms

Figure No. 4570Y/5070Y	NPS	6	8
	DN	150	200
A - End to End		20	24
		508	610
E - Center to Top		10.25	11.375
		260	289
W - Width		17.5	19
		445	483
Weight		520	1330
		234	599

Accessories

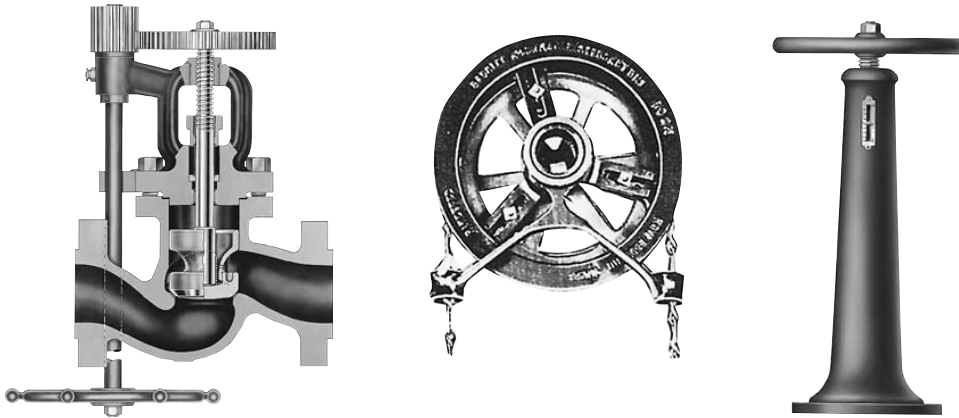

Globe, Angle, Gate

By-Passes for Larger Cast Steel Valves (See Pg. 118)

Edward by-pass valves conform to the latest edition of MSS-SP45 of the Manufacturers Standardization Society of the Valve and Fittings Industry.

Unless otherwise specified when globe and angle valves are ordered with by-pass attached, the by-pass is attached to the left hand side of the valve when viewed from the overseat end.

Edward Forged Steel Valves for use as by-passes

Socket Welding Ends Only		Class 600	Class 900	Class 1500	Class 2500	Series 4500
For use on main stop valve	Globe style, By-pass	Fig. A848Y*	Fig. D36224	Fig. D36224	Fig. D66224	Fig. D96224
For use on main stop-check valve	Globe style, By-pass	Fig. A868Y**	Fig. D36264	Fig. D36264	Fig. D66264	Fig. D96264

* ALL MOTOR ACTUATED BY-PASS VALVES WILL BE FURNISHED WITH FIG. D36224.

** ALL MOTOR ACTUATED BY-PASS VALVES WILL BE FURNISHED WITH FIG. D36264.

Standard sizes of by-pass valves*

Main valve size (all pressures)	4	5	6	8	10 to 24
By-Pass size	½	¾	¾	¾	1

* By-passes are provided only when specified. Standard sizes of by-pass valves are in accordance with the table above. Larger size by-pass valves will be furnished on special order.

Floor Stands

Edward floor stands are cast iron or fabricated steel, and are designed and machined for accurate alignment. They are regularly furnished painted and are faced on bottom and drilled. Two heights, 20 and 32 inches, are available and can be furnished in indicating or non-indicating types. Spur and motor control floor stands can be furnished to meet special conditions.

Chain Wheels

A simple and efficient means of valve operation from a lower level is provided by the use of chain wheels. They are fitted to the regular valve handwheels and are furnished complete with chain wheel and chain guide.

Valve Extension

Illustration shows spur geared valve with extension stem for operation from below. Valves can also be furnished for extension operation above the valve. Larger size valves are also available with bevel gearing.

Accessories – Cast Steel

The following “accessories” or “options” are available for Edward Forged and Cast Steel Valves. Consult your Edward Valves sales representative for specific details.

Impactor Handwheel

Larger size Edward Valves (except gate valves) feature an Impactor handwheel that permits one or two men to develop several thousand ft. lbs. of torque for final valve closure — up to twelve times the force of an ordinary handwheel.



Impactogear®

The Edward Impactogear makes cycling of larger, high pressure valves a one man operation. Impactogear is an exclusive Edward ring gear and pinion assembly that is fastened to an Impactor handwheel and yoke. Using the mechanical advantage of gearing reduction, the assembly permits large valves to be cycled between full open and full closed with an air wrench operating off a nominal air supply. The Impactogear wrench connection is equipped with a safety wrench guard.

Custom Paint

Unless otherwise specified Edward Cast and Forged (carbon or alloy) Steel Valves are painted with a high temperature aluminum lacquer paint. Upon special order Edward Valves can be provided with customer specified paints or coatings.

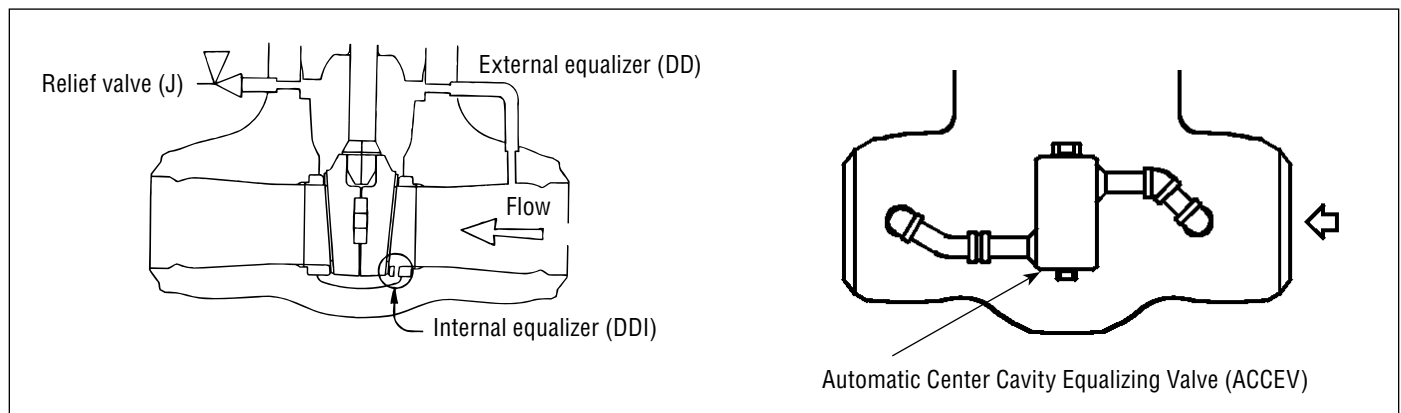

Drain or Vent

All Edward Cast Steel Valves can be supplied with drains and/or vents. A standard drain or vent pipe, six inches long, is socket welded to the valve body, or as specified by the customer.

External Equalizer

A pipe that connects the bonnet cavity of the Equiwedge Gate Valve to the upstream side of the valve. See drawing and page 19 for additional information.

Internal Equalizer

A hole drilled in the upstream seat ring of the Equiwedge Gate Valve for pressure equalization. See drawing for additional information.

Relief Valve

A pressure relief valve can be attached to the bonnet of the Equiwedge Gate Valve to protect against overpressurization, but not prevent pressure locking. See drawing and page 25 for additional information.

Automatic Center Cavity Equalizing Valve

A fully automatic bonnet relief device that allows bi-directional seating even at low pressure differential. See drawing and page 98 for details.

Accessories – Cast Steel

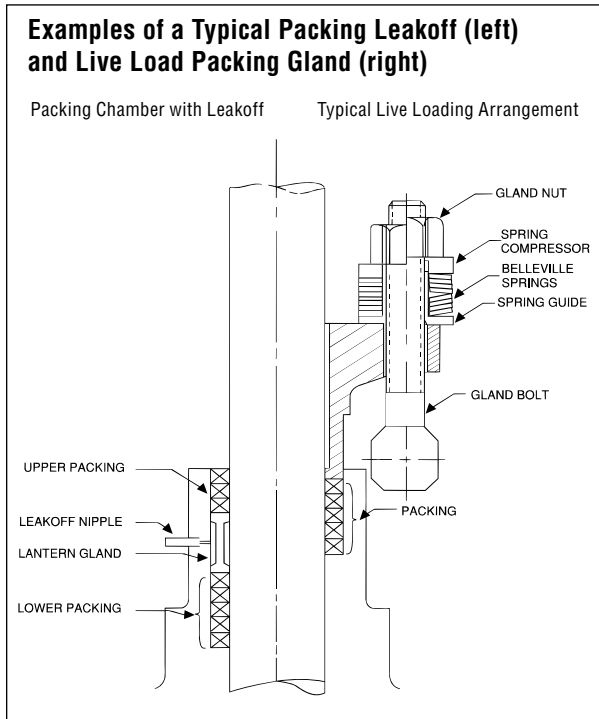

The following “accessories” or “options” are available for Flowserve Edward Forged and Cast Steel Valves. Consult your Flowserve Edward Valves sales representative for specific details.

Leakoff

The left half of the schematic to the right depicts a typical Leakoff arrangement including lantern gland and upper and lower packing sets. This double packing arrangement provides added protection against packing leaks.

Live Loading

The right half of the schematic to the right depicts a typical live loaded packing assembly. The Belleville springs provide a constant packing load to compensate for packing consolidation and thermal effects.

Locking Devices

Edward Valves can be provided with padlock & chain or other locking devices as specified.

Position Indicators & Limit Switches

If required, Edward Valves can be fitted with a variety of position indicators and/or limit switches for remote indication.

Soft Seats

This option is available for both Forged and Cast Steel Globe and Check Valves on a limited basis.

The disk face can be fitted with a soft seat or insert when drop tight sealing is a must. However, some limitations (temperature, differential pressure, radiation) may apply. Consult your Flowserve Edward Valves representative for more information.

Washout Connections

Edward Cast Steel Valves can be fitted with special covers that incorporate a pipe nipple to be used as a washout connection to introduce cleaning solutions etc. for pipeline flushing.

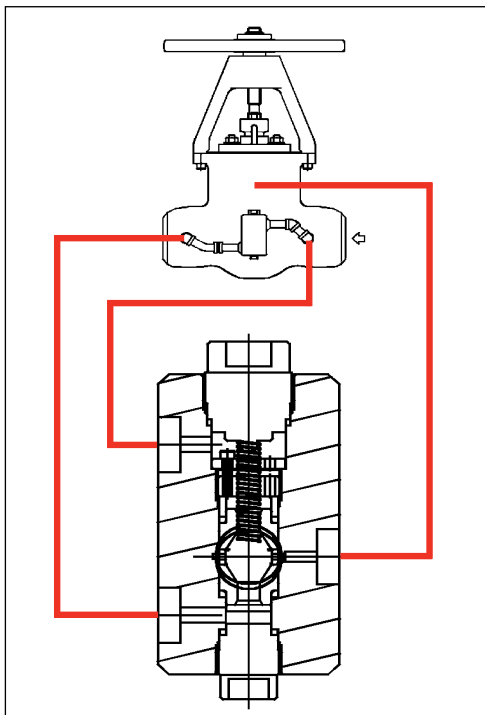

Automatic Center Cavity Equalizing Valve (ACCEV)

The Flowserve Edward ACCEV automatically relieves increasing center cavity pressure to the higher pressure end of the valve, while preventing leakage to the lower pressure end, solving pressure locking and bonnet over-pressurization problems which can occur in double-seated valves. The internal spring gives preferential connection to the designated upstream end of the valve. When system conditions result in the downstream pressure being higher than the upstream, the ball shifts so that the center cavity connects with the downstream end of the valve. The Edward ACCEV meets or exceeds MSS SP-61 for

tight shutoff in both directions. When furnished on an Edward Equi wedge gate valve, all of the necessary connections are made to the host valve and hydro-tested in our factory. No piping connections or testing are required by the user. The Edward ACCEV is available as a kit with necessary piping to be field installed on any existing Edward or other manufacturer’s valve, and can be readily disassembled and repaired in-line in the event any maintenance is required. The Edward ACCEV is available in a commercial B16.34 version for general service and also in an ASME Section III N-Stamp version for nuclear applications.

Actuators – Cast Steel

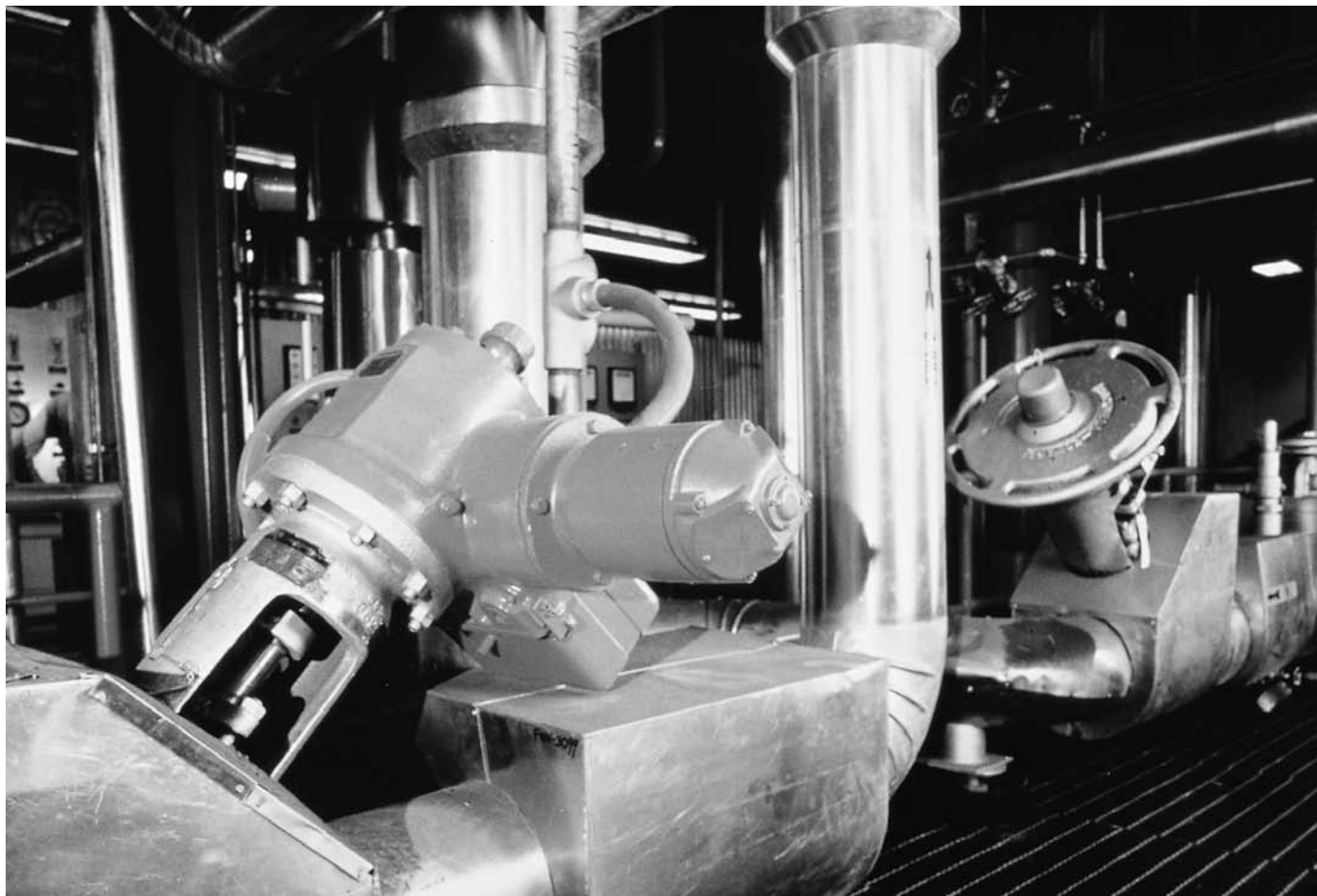

Flowserve Edward Valves supplies actuators for Edward forged and cast steel valves when alternate sources of power are required to open, close or maintain an intermediate position in the valve.

The most commonly used actuators are: electric, pneumatic, hydraulic, manual gear, or a stored energy gas hydraulic used in nuclear applications. Most Edward valves can be equipped with an actuator, if required. Where specific or special customer requirements are needed, Flowserve engineering and expertise with all types of actuators can be applied and adapted to meet the most rigid codes.

The following information on page 100 will allow Flowserve engineers to correctly size and select the proper motor actuator for your application.



Required Information for Motor Actuators

1. OPERATING PRESSURES:

- A) PRESSURE UNDER SEAT = _____ psig
- B) PRESSURE OVER SEAT = _____ psig
- C) PRESSURE DIFFERENTIAL = _____ psig

2. MOTOR POWER SUPPLY*:

- A) AC = _____ V. _____ HZ. _____ PH. _____
- B) DC = _____ V.

*STANDARD VOLTAGE VARIANCE \pm 10%, IF OTHERWISE, PLEASE INDICATE

3. LIMIT SWITCH, TOTAL QUANTITY OF CONTACTS = _____

4. DOUBLE TORQUE SWITCH IS STANDARD.

5. CONTROL POWER SUPPLY TO SWITCH COMPARTMENT = _____

6. CLOSING TIME:

- A) STANDARD (GLOBE VALVES APPROX. 4 IN./MIN., GATE VALVES APPROX. 12 IN./MIN. STEM SPEED.)
- B) SPECIAL _____ INDICATE REQUIRED CLOSING TIME: _____

7. OPTIONAL EQUIPMENT: (PLEASE INDICATE REQUIRED OPTIONS)

- A) MECHANICAL DIAL POSITION INDICATOR
- B) EXTRA TERMINALS
- C) REVERSING MOTOR CONTROLLER: _____ INTEGRAL OR _____ NON-INTEGRAL.
- D) PUSH-BUTTON STATION: _____ INTEGRAL OR _____ NON-INTEGRAL.
- E) POSITION TRANSMITTER, INDICATE TYPE _____
- F) POSITION RECEIVER _____
- H) OTHERS _____

8. AMBIENT CONDITIONS: _____

9. NEMA RATING: *STANDARD IS NEMA 4 (WEATHERPROOF), IF OTHERWISE, PLEASE LIST*

10. STEM POSITION OF INSTALLED VALVE:

- A) VERTICAL UP-RIGHT _____
- B) VERTICAL UP-SIDE DOWN _____
- C) HORIZONTAL _____

Data in the Table above represents the minimum information that should be provided when ordering a valve equipped with a motor operator.

Material Chemical Analysis (ASTM) for Edward Valves

MATERIAL	ELEMENTS	PERCENTAGE*		
		CAST	FORGED	
Carbon Steel (Body) Cast - ASTM A216 Grade WCB Forged - ASTM A105	Carbon	0.30 max.	0.22 max.	
	Manganese	1.00 max.	.60 to 1.05	
	Phosphorus	0.04 max.	0.04 max.	
	Sulfur	0.045 max.	0.05 max.	
	Silicon	0.60 max.	0.35 max.	
Carbon Steel (Body) Cast - ASTM A216-WCC	Carbon	0.25 max.		
	Manganese	1.20 max.		
	Phosphorus	0.04 max.		
	Sulfur	0.045 max.		
	Silicon	0.60 max.		
1¼ Chromium-Molybdenum Steel (Body) Cast - ASTM A217 Grade WC6 Forged - ASTM A182 Grade F11	Carbon	0.20 max.	0.10 to 0.15	
	Manganese	0.50 to 0.80	0.30 to 0.80	
	Phosphorus	0.04 max.	0.04 max.	
	Sulfur	0.045 max.	0.04 max.	
	Silicon	0.60 max.	0.50 to 1.00	
	Chromium	1.00 to 1.50	1.00 to 1.50	
	Molybdenum	0.45 to 0.65	0.44 to 0.65	
2¼ Chromium-Molybdenum Steel (Body) Cast - ASTM A217 Grade WC9 Forged - ASTM A182 Grade F22	Carbon	0.18 max.	0.15 max.	
	Manganese	0.40 to 0.70	0.30 to 0.60	
	Phosphorus	0.04 max.	0.04 max.	
	Sulfur	0.045 max.	0.04 max.	
	Silicon	0.60 max.	0.50 max.	
	Chromium	2.00 to 2.75	2.00 to 2.50	
	Molybdenum	0.90 to 1.20	0.87 to 1.13	
9 Chromium, 1 Molybdenum Steel Body Cast - ASTM A-217 Grade C12A Forged - ASTM A-182 Grade F91	Carbon	0.12 max.	0.08-0.12 max.	
	Manganese	0.30-0.60 max.	0.30-0.60 max.	
	Phosphorus	0.02 max.	0.02 max.	
	Sulfur	0.018 max.	0.01 max.	
	Silicon	0.20-0.50	0.20-0.50 max.	
	Chromium	8.0-9.5	8.00-9.50	
	Molybdenum	0.85-1.05	0.85-1.05	
	Columbium	0.060-0.10	0.060-0.10	
	Vanadium	0.18-0.25	0.18-0.25	
	Nitrogen	0.030-0.070	0.030-0.070	
	Nickel	0.40 max.	0.40 max.	
Austenitic Stainless Steel (Body) Cast - ASTM A-351 Grade CF8M Forged - ASTM A-182 Grade F316	Carbon	0.03 max.	0.08 max.	
	Manganese	1.50 max.	2.00 max.	
	Phosphorus	0.04 max.	0.04 max.	
	Nickel	9.00 to 13.00	10.00 to 14.00	
	Sulfur	0.04 max.	0.03 max.	
	Silicon	1.50 max.	1.00 max.	
	Chromium	17.00 to 21.00	16.00 to 18.00	
	Molybdenum	2.00 to 3.00	2.00 to 3.00	
Martensitic Stainless Steel (Stems) Bolted Bonnet T416 Cast Valves - ASTM A182 Grade F6a Univalves - A-479 T-410 Cl 3	Carbon	0.15 max.	0.15 max.	
	Manganese	1.00 max.	1.25 max.	
	Phosphorus	0.04 max.	0.06 max.	
	Sulfur	0.03 max.	0.15 min.	
	Silicon	1.00 max.	1.00 max.	
	Nickel	0.50 max.	—	
	Chromium	11.50 to 13.50	12.00 to 14.00	
	Molybdenum	—	0.60 max.	
Aluminum Bronze (Yoke Bushings) Cast Valves - ASTM B 148 Alloy 95400 Forged Valves - ASTM B150 Alloy 61900-62300			61900	62300
	Copper	remainder	remainder	remainder
	Aluminum	10.00 to 11.50	8.50 to 10.00	8.50 to 11.00
	Iron	3.00 to 5.00	3.00 to 4.50	2.00 to 4.00
	Tin	—	0.60 max.	0.60 max.
	Lead	—	0.80 max.	—
	Manganese	0.50 max.	—	0.50 max.
	Zinc	—	0.02 max.	—
	Silicon	—	—	0.25 max.
	Nickel & Cobalt	1.50 max.	—	1.00 max.
Chromium-Molybdenum (Bolting) ASTM A193 Grade B7 Forged - ASTM A105	Carbon		0.37 to 0.49	
	Manganese		0.65 to 1.10	
	Phosphorus		0.035 max.	
	Sulfur		0.04 max.	
	Silicon		0.15 to 0.35	
	Chromium		0.75 to 1.20	
	Molybdenum		0.15 to 0.25	
Hard Surfacing for Seats and Disks A732 Grade 21 & Stellite 21®	Chromium		25.00 to 29.00	
	Manganese		1.00 max.	
	Molybdenum		5.00 to 6.00	
	Nickel		1.75 to 3.75	
	Iron		3.00	
	Boron		.007 max.	
	Carbon		0.20 to 0.30	
	Silicon		1.00	

This ASTM specification data is provided for customer information. The data was based on information available at time of printing and may not reflect the latest ASTM revision. Flowserve suggests referring to the applicable specification for complete information or contacting your Edward Valves sales representative.

*The equivalent Edward valve material specification for valve bodies meets all of the requirements of the referenced ASTM Specification; additionally Flowserve restricts certain elements (i.e. carbon, manganese) to tighter allowable ranges to enhance weldability.



Reference: ASME B16.34 – 2004 Pressure/Temperature Ratings

Cast Steel* (Gate, Globe & Check Valves)

RATING	TEMP. °F	PRESSURE (PSIG)												
		300	400	600	700	900	1100	1500	1800	2000	2500	2900	3600	4500
ASTM A216-WCB STANDARD CLASS (1) (2)	-20 to 100	740	985	1480	1725	2220	2715	3705	4445	4940	6170	7160	8885	11110
	200	680	905	1360	1585	2035	2490	3395	4075	4525	5655	6560	8145	10185
	300	655	875	1310	1530	1965	2400	3270	3925	4360	5450	6325	7850	9815
	400	635	845	1265	1475	1900	2325	3170	3805	4225	5280	6125	7605	9505
	500	605	805	1205	1405	1810	2210	3015	3620	4020	5025	5830	7235	9040
	600	570	760	1135	1325	1705	2085	2840	3405	3785	4730	5485	6810	8515
	650	550	735	1100	1285	1650	2015	2745	3295	3660	4575	5310	6590	8240
	700	530	705	1060	1235	1590	1950	2665	3195	3545	4425	5130	6370	7960
	750	505	675	1015	1185	1520	1860	2535	3045	3385	4230	4905	6090	7610
	800	410	550	825	960	1235	1510	2055	2470	2745	3430	3980	4935	6170
	850	320	425	640	745	955	1170	1595	1915	2125	2655	3080	3825	4785
	900	230	305	460	535	690	845	1150	1380	1535	1915	2225	2760	3455
	950	135	180	275	320	410	500	685	825	915	1145	1325	1645	2055
	1000	85	115	170	200	255	315	430	515	575	715	830	1030	1285
ASTM A216-WCB SPECIAL CLASS (1) (2)	-20 to 100	750	1000	1500	1750	2250	2750	3750	4500	5000	6250	7250	9000	11250
	200	750	1000	1500	1750	2250	2750	3750	4500	5000	6250	7250	9000	11250
	300	740	985	1480	1725	2220	2715	3700	4440	4935	6170	7155	8885	11105
	400	735	980	1465	1710	2200	2690	3665	4395	4885	6105	7085	8795	10995
	500	735	980	1465	1710	2200	2690	3665	4395	4885	6105	7085	8795	10995
	600	735	980	1465	1710	2200	2690	3665	4395	4885	6105	7085	8795	10995
	650	715	955	1430	1670	2145	2620	3575	4290	4770	5960	6915	8585	10730
	700	690	920	1380	1610	2075	2535	3455	4145	4610	5760	6680	8295	10365
	750	635	845	1270	1480	1905	2325	3170	3805	4230	5285	6130	7610	9515
	800	515	685	1030	1200	1545	1885	2570	3085	3430	4285	4970	6170	7715
	850	400	530	795	930	1195	1460	1995	2395	2660	3320	3850	4785	5980
	900	285	380	575	670	860	1050	1435	1725	1915	2395	2775	3445	4305
	950	170	230	345	400	515	630	855	1030	1145	1430	1660	2055	2570
	1000	105	140	215	250	320	390	535	645	715	895	1035	1285	1605

IMPORTANT: The above ratings are only for reference. Refer to ASME B16.34 for pressure/temperature ratings.

Note: Flanged End Valve ratings are limited to standard class only.

1. Permissible but not recommended for prolonged use at temperatures above approx. 800°F.

2. Shaded ratings exceed those of standard Edward Valves. Consult your Edward Valves sales representative for applications in these ranges.

* Pressure temperature ratings are from ASME B16.34 "Valves, Flanged, Threaded and Welding Ends." Consult your Flowserve sales representative for pressure temperature ratings of materials not included in this catalog.

** Series 4500 rated Cast Steel Valves do not comply with ASME Class 4500 ratings. Consult your Flowserve sales representative for pressure temperature ratings of these valves. See 3.2 Pressure Ratings in the Technical Information section for additional information.

Reference: ASME B16.34 – 2004 Pressure/Temperature Ratings (metric)

Cast Steel* (Gate, Globe & Check Valves)

RATING	TEMP. °C	PRESSURE (BAR)												
		300	400	600	700	900	1100	1500	1800	2000	2500	2900	3600	4500
ASTM A216-WCB STANDARD CLASS (1) (2)	-29 to 38	51.1	68.1	102.1	119.1	153.2	187.2	255.3	306.4	340.4	425.5	493.6	612.7	765.9
	50	50.1	66.8	100.2	116.9	150.4	183.8	250.6	300.7	334.2	417.7	484.5	601.5	751.9
	100	46.6	62.1	93.2	108.7	139.8	170.9	233.0	279.6	310.7	388.3	450.4	559.2	699.0
	150	45.1	60.1	90.2	105.2	135.2	165.3	225.4	270.5	300.5	375.6	435.7	540.9	676.1
	200	43.8	58.4	87.6	102.2	131.4	160.6	219.0	262.8	292.0	365.0	423.4	525.6	657.0
	250	41.9	55.9	83.9	97.9	125.8	153.8	209.7	251.6	279.6	349.5	405.4	503.3	629.1
	300	39.8	53.1	79.6	92.9	119.5	146.0	199.1	238.9	265.5	331.8	384.9	477.8	597.3
	325	38.7	51.6	77.4	90.3	116.1	141.9	193.6	232.3	258.1	322.6	374.2	464.6	580.7
	350	37.6	50.1	75.1	87.6	112.7	137.7	187.8	225.4	250.4	313.0	363.1	450.8	563.5
	375	36.4	48.5	72.7	84.8	109.1	133.3	181.8	218.2	242.5	303.1	351.6	436.4	545.5
	400	34.7	46.3	69.4	81.0	104.2	127.3	173.6	208.3	231.5	289.3	335.6	416.6	520.8
	425	28.8	38.4	57.5	67.1	86.3	105.5	143.8	172.6	191.8	239.7	278.1	345.2	431.5
	450	23.0	30.7	46.0	53.7	69.0	84.3	115.0	138.0	153.4	191.7	222.4	276.1	345.1
	475	17.4	23.2	34.9	40.7	52.3	63.9	87.2	104.6	116.3	145.3	168.5	209.2	261.5
	500	11.8	15.7	23.5	27.4	35.3	43.1	58.8	70.5	78.4	97.9	113.6	141.0	176.3
	538	5.9	7.9	11.8	13.8	17.7	21.6	29.5	35.4	39.4	49.2	57.1	70.9	88.6
ASTM A216-WCB SPECIAL CLASS (1) (2)	-29 to 38	51.7	68.9	103.4	120.6	155.1	189.6	258.6	310.3	344.8	430.9	499.9	620.5	775.7
	50	51.7	68.9	103.4	120.6	155.1	189.6	258.6	310.3	344.8	430.9	499.9	620.5	775.7
	100	51.6	68.8	103.3	120.5	154.9	189.3	258.2	309.8	344.3	430.3	499.1	619.6	774.5
	150	51.0	68.0	102.1	119.1	153.1	187.1	255.2	306.2	340.3	425.3	493.3	612.4	765.5
	200	50.6	67.4	101.1	118.0	151.7	185.4	252.9	303.5	337.2	421.4	488.8	606.9	758.6
	250	50.5	67.4	101.1	117.9	151.6	185.3	252.6	303.2	336.9	421.1	488.5	606.3	757.9
	300	50.5	67.4	101.1	117.9	151.6	185.3	252.6	303.2	336.9	421.1	488.5	606.3	757.9
	325	50.1	66.8	100.2	116.9	150.3	183.7	250.6	300.7	334.1	417.6	484.4	601.4	751.7
	350	48.9	65.2	97.8	114.1	146.7	179.3	244.6	293.5	326.1	407.6	472.8	587.0	733.7
	375	47.1	62.8	94.2	109.9	141.3	172.7	235.5	282.6	314.0	392.5	455.3	565.2	706.5
	400	43.4	57.9	86.8	101.3	130.2	159.1	217.0	260.4	289.4	361.7	419.6	520.8	651.0
	425	36.0	48.0	71.9	83.9	107.9	131.9	179.8	215.7	239.7	299.6	347.5	431.4	539.3
	450	28.8	38.4	57.5	67.1	86.3	105.5	143.8	172.5	191.7	239.6	278.0	345.1	431.4
	475	21.8	29.1	43.6	50.9	65.4	79.9	109.0	130.8	145.3	181.6	210.7	261.5	326.9
	500	14.7	19.6	29.4	34.3	44.1	53.9	73.5	88.2	98.0	122.4	142.0	176.3	220.4
	538	7.4	9.9	14.8	17.3	22.2	27.1	36.9	44.3	49.3	61.6	71.4	88.7	110.8

IMPORTANT: The above ratings are only for reference. Refer to ASME B16.34 for pressure/temperature ratings.

1. Permissible but not recommended for prolonged use at temperatures above approx. 427°C.

2. Shaded ratings exceed those of standard Edward Valves. Consult your Flowserve sales representative for applications in these ranges.

*Pressure temperature ratings are from ASME B16.34 "Valves, Flanged, Threaded and Welding Ends." Consult your Flowserve sales representative for pressure temperature ratings of materials not included in this catalog.



Reference: ASME B16.34 – 2004 Pressure/Temperature Ratings

Cast Steel* (Gate, Globe & Check Valves)

RATING	TEMP. °F	PRESSURE (PSIG)												
		300	400	600	700	900	1100	1500	1800	2000	2500	2900	3600	4500
A216-WCC GROUP 1.2 STANDARD CLASS (1) (2)	100	750	1,000	1,500	1,750	2,250	2,750	3,750	4,500	5,000	6,250	7,250	9,000	11,250
	200	750	1,000	1,500	1,750	2,250	2,750	3,750	4,500	5,000	6,250	7,250	9,000	11,250
	300	730	970	1,455	1,700	2,185	2,670	3,640	4,370	4,855	6,070	7,040	8,740	10,925
	400	705	940	1,405	1,640	2,110	2,580	3,520	4,225	4,695	5,865	6,805	8,445	10,555
	500	665	890	1,330	1,550	1,995	2,440	3,325	3,990	4,435	5,540	6,425	7,975	9,965
	600	605	810	1,210	1,410	1,815	2,220	3,025	3,630	4,035	5,040	5,845	7,260	9,070
	650	590	785	1,175	1,370	1,765	2,160	2,940	3,530	3,925	4,905	5,690	7,060	8,825
	700	555	740	1,110	1,295	1,665	2,035	2,775	3,330	3,705	4,630	5,370	6,665	8,330
	750	505	675	1,015	1,180	1,520	1,860	2,535	3,045	3,385	4,230	4,905	6,090	7,610
	800	410	550	825	960	1,235	1,510	2,055	2,470	2,745	3,430	3,980	4,940	6,170
	850	320	430	640	745	955	1,170	1,595	1,915	2,125	2,655	3,080	3,830	4,785
	900	225	300	445	520	670	820	1,115	1,340	1,485	1,855	2,155	2,675	3,345
	950	135	180	275	320	410	500	685	825	915	1,145	1,330	1,645	2,055
	1000	85	115	170	200	255	315	430	515	575	715	830	1,030	1,285
	A216-WCC GROUP 1.2 SPECIAL CLASS (1) (2)	100	750	1,000	1,500	1,750	2,250	2,750	3,750	4,500	5,000	6,250	7,250	9,000
200		750	1,000	1,500	1,750	2,250	2,750	3,750	4,500	5,000	6,250	7,250	9,000	11,250
300		750	1,000	1,500	1,750	2,250	2,750	3,750	4,500	5,000	6,250	7,250	9,000	11,250
400		750	1,000	1,500	1,750	2,250	2,750	3,750	4,500	5,000	6,250	7,250	9,000	11,250
500		750	1,000	1,500	1,750	2,250	2,750	3,750	4,500	5,000	6,250	7,250	9,000	11,250
600		750	1,000	1,500	1,750	2,250	2,750	3,750	4,500	5,000	6,250	7,250	9,000	11,250
650		750	1,000	1,500	1,750	2,250	2,750	3,750	4,500	5,000	6,250	7,250	9,000	11,250
700		715	950	1,425	1,660	2,140	2,615	3,565	4,280	4,755	5,940	6,890	8,550	10,690
750		635	850	1,270	1,480	1,905	2,330	3,170	3,805	4,230	5,285	6,130	7,610	9,515
800		515	690	1,030	1,200	1,545	1,890	2,570	3,085	3,430	4,285	4,970	6,170	7,715
850		400	530	795	930	1,195	1,460	1,995	2,395	2,660	3,320	3,850	4,780	5,980
900		280	370	555	650	835	1,020	1,395	1,675	1,860	2,320	2,690	3,340	4,180
950		170	230	345	400	515	630	855	1,030	1,140	1,430	1,660	2,060	2,570
1000		105	140	215	250	320	390	535	645	715	895	1,040	1,285	1,605

IMPORTANT: The above ratings are only for reference. Refer to ASME B16.34 for pressure/temperature ratings.

Note: Flanged End Valve ratings are limited to standard class only and terminate at 1000°F.

1. Permissible but not recommended for prolonged use at temperatures above approx. 800°F.

2. Shaded ratings may require special trim and packing. Consult your Edward Valves sales representative for applications in these ranges.

* Pressure temperature ratings are from ASME B16.34 "Valves, Flanged, Threaded and Welding Ends." Consult your Flowserve sales representative for pressure temperature ratings of materials not included in this catalog.

** Series 4500 rated Cast Steel Valves do not comply with ASME Class 4500 ratings. Consult your Flowserve sales representative for pressure temperature ratings of these valves. See 3.2 Pressure Ratings in the Technical Information section for additional information.

Reference: ASME B16.34 – 2004 Pressure/Temperature Ratings (metric)

Cast Steel* (Gate, Globe & Check Valves)

1 bar = 100 kPa = 14.50 psi

RATING	TEMP. °C	PRESSURE (BAR)													
		300	400	600	700	900	1100	1500	1800	2000	2500	2900	3600	4500	
A216-WCC GROUP 1.2 SPECIAL CLASS (1) (2)	38	51.7	68.9	103.4	120.6	155.1	189.6	258.6	310.3	344.8	430.9	499.9	620.5	775.7	
	50	51.7	68.9	103.4	120.6	155.1	189.6	258.6	310.3	344.8	430.9	499.9	620.5	775.7	
	100	51.5	68.7	103.0	120.2	154.6	188.9	257.6	309.1	343.5	429.4	498.1	618.4	773.0	
	150	50.2	66.9	100.3	117.0	150.5	183.9	250.8	301.0	334.5	418.1	485.0	602.1	752.6	
	200	48.6	64.8	97.2	113.4	145.8	178.3	243.2	291.9	324.3	405.4	470.3	583.8	729.7	
	250	46.3	61.6	92.2	107.8	139.0	169.9	231.8	278.1	309.0	386.2	447.9	555.9	694.8	
	300	42.9	57.2	85.7	100.0	128.6	157.2	214.4	257.2	285.8	357.1	414.2	514.1	642.6	
	325	41.4	55.1	82.6	96.4	124.0	151.5	206.6	247.9	275.5	344.3	399.4	495.7	619.6	
	350	40.0	53.3	80.0	93.4	120.1	146.8	200.1	240.1	266.8	333.5	386.9	480.2	600.3	
	375	37.8	50.4	75.7	88.3	113.5	138.7	189.2	227.0	252.3	315.3	365.7	454.0	567.5	
	400	34.7	46.3	69.4	81.0	104.2	127.3	173.6	208.3	231.5	289.3	335.6	416.6	520.8	
	425	28.8	38.4	57.5	67.1	86.3	105.5	143.8	172.6	191.8	239.7	278.1	345.2	431.5	
	450	23.0	30.7	46.0	53.7	69.0	84.3	115.0	138.0	153.4	191.7	222.4	276.1	345.1	
	475	17.1	22.8	34.2	39.9	51.3	62.7	85.4	102.5	113.9	142.4	165.2	205.0	256.3	
	500	11.6	15.5	23.2	27.0	34.7	42.4	57.9	69.5	77.2	96.5	111.9	139.0	173.7	
	538	5.9	7.9	11.8	13.8	17.7	21.6	29.5	35.4	39.4	49.2	57.1	70.9	88.6	
	A216-WCC GROUP 1.2 SPECIAL CLASS (1) (2)	38	51.7	68.9	103.4	120.6	155.1	189.6	258.6	310.3	344.8	430.9	499.9	620.5	775.7
50		51.7	68.9	103.4	120.6	155.1	189.6	258.6	310.3	344.8	430.9	499.9	620.5	775.7	
100		51.7	68.9	103.4	120.6	155.1	189.6	258.6	310.3	344.8	430.9	499.9	620.5	775.7	
150		51.7	68.9	103.4	120.6	155.1	189.6	258.6	310.3	344.8	430.9	499.9	620.5	775.7	
200		51.7	68.9	103.4	120.6	155.1	189.6	258.6	310.3	344.8	430.9	499.9	620.5	775.7	
250		51.7	68.9	103.4	120.6	155.1	189.6	258.6	310.3	344.8	430.9	499.9	620.5	775.7	
300		51.7	68.9	103.4	120.6	155.1	189.6	258.6	310.3	344.8	430.9	499.9	620.5	775.7	
325		51.7	68.9	103.4	120.6	155.1	189.6	258.6	310.3	344.8	430.9	499.9	620.5	775.7	
350		51.1	68.1	102.2	119.2	153.3	187.4	255.5	306.6	340.7	425.8	493.9	613.1	766.4	
375		48.4	64.5	96.7	112.8	145.1	177.4	241.9	290.3	322.5	403.1	467.6	580.5	725.6	
400		43.4	57.9	86.8	101.3	130.2	159.1	217.0	260.4	289.4	361.7	419.6	520.8	651.0	
425		36.0	48.0	71.9	83.9	107.9	131.9	179.8	215.7	239.7	299.6	347.5	431.4	539.3	
450		28.8	38.4	57.5	67.1	86.3	105.5	143.8	172.5	191.7	239.6	278.0	345.1	431.4	
475		24.4	30.5	42.7	49.8	64.1	78.3	106.8	128.2	142.4	178.0	206.5	256.3	320.4	
500		14.5	19.3	29.0	33.8	43.4	53.1	72.4	86.9	96.6	120.7	140.0	173.8	217.2	
538		7.4	9.9	14.8	17.3	22.2	27.1	36.9	44.3	49.3	61.6	71.4	88.7	110.8	

IMPORTANT: The above ratings are only for reference. Refer to ASME B16.34 for pressure/temperature ratings.

1. Permissible but not recommended for prolonged use at temperatures above approx. 427°C.

2. Shaded ratings may require special trim and packing. Consult your Flowserve sales representative for applications in these ranges.

*Pressure temperature ratings are from ASME B16.34 "Valves, Flanged, Threaded and Welding Ends." Consult your Flowserve sales representative for pressure temperature ratings of materials not included in this catalog.



Reference: ASME B16.34 – 2004 Pressure/Temperature Ratings

Cast Steel* (Gate, Globe & Check Valves)

RATING	TEMP. °F	PRESSURE (PSIG)												
		300	400	600	700	900	1100	1500	1800	2000	2500	2900	3600	4500
ASTM A-217-WC6 STANDARD CLASS (1)	-20 to 100	750	1000	1500	1750	2250	2750	3750	4500	5000	6250	7250	9000	11250
	200	750	1000	1500	1750	2250	2750	3750	4500	5000	6250	7250	9000	11250
	300	720	960	1445	1685	2165	2645	3610	4330	4815	6015	6980	8665	10830
	400	695	925	1385	1615	2080	2540	3465	4160	4620	5775	6700	8320	10400
	500	665	885	1330	1550	1995	2440	3325	3990	4435	5540	6425	7975	9965
	600	605	805	1210	1410	1815	2220	3025	3630	4035	5040	5845	7255	9070
	650	590	785	1175	1370	1765	2155	2940	3530	3925	4905	5690	7060	8825
	700	570	760	1135	1325	1705	2085	2840	3405	3785	4730	5485	6810	8515
	750	530	710	1065	1240	1595	1950	2660	3190	3545	4430	5140	6375	7970
	800	510	680	1015	1185	1525	1865	2540	3045	3385	4230	4905	6090	7610
	850	485	650	975	1135	1460	1785	2435	2925	3250	4060	4710	5845	7305
	900	450	600	900	1050	1350	1650	2245	2695	2995	3745	4345	5390	6740
	950	320	425	640	745	955	1170	1595	1915	2125	2655	3080	3825	4785
	1000	215	285	430	505	650	795	1080	1295	1440	1800	2090	2590	3240
	1050	145	195	290	335	430	525	720	865	960	1200	1390	1730	2160
	1100	95	125	190	225	290	355	480	575	640	800	930	1150	1440
	ASTM A-217-WC6 SPECIAL CLASS (1)	-20 to 100	750	1000	1500	1750	2250	2750	3750	4500	5000	6250	7250	9000
200		750	1000	1500	1750	2250	2750	3750	4500	5000	6250	7250	9000	11250
300		750	1000	1500	1750	2250	2750	3750	4500	5000	6250	7250	9000	11250
400		750	1000	1500	1750	2250	2750	3750	4500	5000	6250	7250	9000	11250
500		750	1000	1500	1750	2250	2750	3750	4500	5000	6250	7250	9000	11250
600		750	1000	1500	1750	2250	2750	3750	4500	5000	6250	7250	9000	11250
650		750	1000	1500	1750	2250	2750	3750	4500	5000	6250	7250	9000	11250
700		735	980	1465	1710	2200	2690	3665	4400	4890	6110	7085	8795	10995
750		730	975	1460	1700	2185	2670	3645	4375	4860	6070	7040	8745	10930
800		720	960	1440	1680	2160	2640	3600	4320	4800	6000	6960	8640	10800
850		680	905	1355	1580	2030	2480	3385	4065	4515	5645	6550	8130	10160
900		585	780	1175	1370	1760	2150	2935	3525	3915	4895	5675	7045	8805
950		400	530	795	930	1195	1460	1995	2395	2660	3320	3850	4785	5980
1000		270	360	540	630	810	990	1350	1620	1800	2250	2610	3240	4050
1050		180	240	360	420	540	660	900	1080	1200	1500	1740	2160	2700
1100		120	160	240	280	360	440	600	720	800	1000	1160	1440	1800

IMPORTANT: The above ratings are only for reference. Refer to ASME B16.34 for pressure/temperature ratings.

Note: Flanged End Valve ratings are limited to standard class only and terminate at 1000°F.

1. Shaded ratings may require special trim and packing. Consult your Edward Valves sales representative for applications in these ranges.

* Pressure temperature ratings are from ASME B16.34 "Valves, Flanged, Threaded and Welding Ends." Consult your Flowserve sales representative for pressure temperature ratings of materials not included in this catalog.

** Series 4500 rated Cast Steel Valves do not comply with ASME Class 4500 ratings. Consult your Flowserve sales representative for pressure temperature ratings of these valves. See 3.2 Pressure Ratings in the Technical Information section for additional information.

Reference: ASME B16.34 – 2004 Pressure/Temperature Ratings (metric)

Cast Steel* (Gate, Globe & Check Valves)

1 bar = 100 kPa = 14.50 psi

RATING	TEMP. °C	PRESSURE (BAR)												
		300	400	600	700	900	1100	1500	1800	2000	2500	2900	3600	4500
ASTM A-217-WC6 STANDARD CLASS (1)	-29 to 38	51.7	68.9	103.4	120.6	155.1	189.6	258.6	310.3	344.8	430.9	499.9	620.5	775.7
	50	51.7	68.9	103.4	120.6	155.1	189.6	258.6	310.3	344.8	430.9	499.9	620.5	775.7
	100	51.5	68.7	103.0	120.1	154.4	188.7	257.4	308.9	343.2	429.0	497.6	617.8	772.2
	150	49.7	66.3	99.5	116.1	149.2	182.4	248.7	298.4	331.6	414.5	480.8	596.9	746.2
	200	48.0	64.0	95.9	111.9	143.9	175.9	239.8	287.7	319.7	399.6	463.6	575.5	719.4
	250	46.3	61.8	92.7	108.1	139.0	169.9	231.8	278.1	309.0	386.2	447.9	555.9	694.8
	300	42.9	57.2	85.7	100.0	128.6	157.2	214.4	257.2	285.8	357.1	414.2	514.1	642.6
	325	41.4	55.1	82.6	96.4	124.0	151.5	206.6	247.9	275.5	344.3	399.4	495.7	619.6
	350	40.3	53.7	80.4	93.8	120.7	147.5	201.1	241.4	268.2	335.3	388.9	482.7	603.3
	375	38.9	51.8	77.6	90.6	116.5	142.4	194.1	232.8	258.7	323.2	374.9	465.4	581.8
	400	36.5	48.8	73.3	85.5	109.8	134.2	183.1	219.6	244.0	304.9	353.6	438.9	548.5
	425	35.2	46.8	70.0	81.7	105.1	128.4	175.1	210.1	233.4	291.6	338.2	419.8	524.7
	450	33.7	45.0	67.7	78.9	101.4	123.9	169.0	202.8	225.4	281.8	326.8	405.7	507.0
	475	31.7	42.3	63.4	74.0	95.1	116.1	158.2	189.9	211.1	263.9	306.1	379.9	474.8
	500	25.7	34.3	51.5	60.1	77.2	94.3	128.6	154.3	171.5	214.4	248.7	308.7	385.9
	538	14.9	19.9	29.8	34.8	44.7	54.6	74.5	89.4	99.3	124.1	144.0	178.7	223.4
	550	12.7	16.9	25.4	29.6	38.1	46.6	63.5	76.2	84.7	105.9	122.8	152.5	190.6
	575	8.8	11.7	17.6	20.5	26.4	32.3	44.0	52.8	58.7	73.4	85.1	105.6	132.0
	595	6.6	8.9	13.3	15.5	19.9	24.3	33.2	39.9	44.3	55.4	64.3	79.8	99.7
ASTM A-217-WC6 SPECIAL CLASS (1)	-29 to 38	51.7	68.9	103.4	120.6	155.1	189.6	258.6	310.3	344.8	430.9	499.9	620.5	775.7
	50	51.7	68.9	103.4	120.6	155.1	189.6	258.6	310.3	344.8	430.9	499.9	620.5	775.7
	100	51.7	68.9	103.4	120.6	155.1	189.6	258.6	310.3	344.8	430.9	499.9	620.5	775.7
	150	51.7	68.9	103.4	120.6	155.1	189.6	258.6	310.3	344.8	430.9	499.9	620.5	775.7
	200	51.7	68.9	103.4	120.6	155.1	189.6	258.6	310.3	344.8	430.9	499.9	620.5	775.7
	250	51.7	68.9	103.4	120.6	155.1	189.6	258.6	310.3	344.8	430.9	499.9	620.5	775.7
	300	51.7	68.9	103.4	120.6	155.1	189.6	258.6	310.3	344.8	430.9	499.9	620.5	775.7
	325	51.7	68.9	103.4	120.6	155.1	189.6	258.6	310.3	344.8	430.9	499.9	620.5	775.7
	350	51.5	68.6	102.8	120.0	154.3	188.6	257.1	308.6	342.9	428.6	497.2	617.1	771.4
	375	50.6	67.4	101.0	117.8	151.5	185.2	252.5	303.0	336.7	420.9	488.2	606.0	757.4
	400	50.3	67.1	100.6	117.3	150.6	184.1	251.2	301.3	334.8	418.3	485.3	602.5	753.2
	425	49.6	66.2	99.3	115.8	148.9	182.0	248.2	297.9	331.0	413.7	479.9	595.7	744.6
	450	47.3	63.0	94.4	110.1	141.4	172.9	235.8	283.0	314.5	393.1	456.0	566.1	707.6
	475	42.8	57.0	85.5	99.7	128.2	156.7	213.7	256.5	285.0	356.3	413.3	513.1	641.3
	500	32.2	42.9	64.3	75.0	96.5	117.9	160.8	193.0	214.4	268.0	310.9	385.9	482.4
	538	18.6	24.8	37.2	43.4	55.8	68.2	93.1	111.7	124.1	155.1	179.9	223.4	279.2
	550	15.9	21.2	31.8	37.1	47.7	58.3	79.4	95.3	105.9	132.4	153.6	190.6	238.3
	575	11.0	14.7	22.0	25.7	33.0	40.3	55.0	66.0	73.4	91.7	106.4	132.1	165.1
	595	8.3	11.1	16.6	19.4	24.9	30.5	41.6	49.9	55.4	69.2	80.3	99.7	124.6

IMPORTANT: The above ratings are only for reference. Refer to ASME B16.34 for pressure/temperature ratings.

1. Shaded ratings may require special trim and packing. Consult your Flowserve sales representative for applications in these ranges.

*Pressure temperature ratings are from ASME B16.34 "Valves, Flanged, Threaded and Welding Ends." Consult your Flowserve sales representative for pressure temperature ratings of materials not included in this catalog.



Reference: ASME B16.34 – 2004 Pressure/Temperature Ratings

Cast Steel* (Gate, Globe & Check Valves)

RATING	TEMP. °F	PRESSURE (PSIG)												
		300	400	600	700	900	1100	1500	1800	2000	2500	2900	3600	4500
ASTM A217-WC9 STANDARD CLASS	-20 to 100	750	1000	1500	1750	2250	2750	3750	4500	5000	6250	7250	9000	11250
	200	750	1000	1500	1750	2250	2750	3750	4500	5000	6250	7250	9000	11250
	300	730	970	1455	1700	2185	2670	3640	4370	4855	6070	7040	8740	10925
	400	705	940	1410	1645	2115	2585	3530	4235	4705	5880	6820	8470	10585
	500	665	885	1330	1550	1995	2440	3325	3990	4435	5540	6425	7975	9965
	600	605	805	1210	1410	1815	2220	3025	3630	4035	5040	5845	7255	9070
	650	590	785	1175	1370	1765	2155	2940	3530	3925	4905	5690	7060	8825
	700	570	760	1135	1325	1705	2085	2840	3405	3785	4730	5485	6810	8515
	750	530	710	1065	1240	1595	1950	2660	3190	3545	4430	5140	6375	7970
	800	510	680	1015	1185	1525	1865	2540	3045	3385	4230	4905	6090	7610
	850	485	650	975	1135	1460	1785	2435	2925	3250	4060	4710	5845	7305
	900	450	600	900	1050	1350	1650	2245	2695	2995	3745	4345	5390	6740
	950	385	510	755	890	1160	1415	1930	2315	2575	3220	3735	4635	5795
	1000	265	355	535	625	800	980	1335	1605	1785	2230	2585	3210	4010
	1050	175	235	350	410	525	640	875	1050	1165	1455	1690	2100	2625
	1100	110	145	220	255	330	405	550	660	735	915	1060	1315	1645
ASTM A217-WC9 SPECIAL CLASS	-20 to 100	750	1000	1500	1750	2250	2750	3750	4500	5000	6250	7250	9000	11250
	200	750	1000	1500	1750	2250	2750	3750	4500	5000	6250	7250	9000	11250
	300	740	985	1480	1725	2220	2710	3695	4435	4930	6160	7145	8870	11090
	400	730	970	1455	1700	2185	2670	3640	4370	4855	6065	7035	8735	10915
	500	725	965	1450	1690	2175	2655	3620	4345	4830	6035	7000	8690	10865
	600	720	960	1440	1680	2165	2645	3605	4325	4810	6010	6970	8655	10815
	650	715	955	1430	1670	2145	2625	3580	4295	4775	5965	6920	8590	10735
	700	705	940	1415	1650	2120	2590	3535	4245	4715	5895	6835	8485	10605
	750	705	940	1415	1650	2120	2590	3535	4245	4715	5895	6835	8485	10605
	800	705	940	1415	1650	2120	2590	3535	4245	4715	5895	6835	8485	10605
	850	680	905	1355	1580	2030	2480	3385	4065	4515	5645	6550	8130	10160
	900	600	800	1200	1400	1800	2200	3000	3600	4000	5000	5800	7200	9000
	950	470	630	945	1100	1415	1730	2360	2830	3145	3930	4560	5655	7070
	1000	335	445	670	780	1005	1225	1670	2005	2230	2785	3230	4010	5015
	1050	220	290	435	510	655	800	1095	1315	1460	1820	2110	2625	3280
	1100	135	180	275	320	410	500	685	825	915	1145	1325	1645	2055

IMPORTANT: The above ratings are only for reference. Refer to ASME B16.34 for pressure/temperature ratings.

* Pressure temperature ratings are from ASME B16.34 "Valves, Flanged, Threaded and Welding Ends." Consult your Flowserve sales representative for pressure temperature ratings of materials not included in this catalog.

** Series 4500 rated Cast Steel Valves do not comply with ASME Class 4500 ratings. Consult your Flowserve sales representative for pressure temperature ratings of these valves. See 3.2 Pressure Ratings in the Technical Information section for additional information.

Reference: ASME B16.34 – 2004 Pressure/Temperature Ratings (metric)

Cast Steel* (Gate, Globe & Check Valves)

1 bar = 100 kPa = 14.50 psi

RATING	TEMP. °C	PRESSURE (BAR)												
		300	400	600	700	900	1100	1500	1800	2000	2500	2900	3600	4500
ASTM A-217-WC9 STANDARD CLASS (1)	-29 to 38	51.7	68.9	103.4	120.6	155.1	189.6	258.6	310.3	344.8	430.9	499.9	620.5	775.7
	50	51.7	68.9	103.4	120.6	155.1	189.6	258.6	310.3	344.8	430.9	499.9	620.5	775.7
	100	51.5	68.7	103.0	120.2	154.6	188.9	257.6	309.1	343.5	429.4	498.1	618.4	773.0
	150	50.3	67.0	100.3	117.1	150.6	184.0	250.8	301.0	334.5	418.2	485.1	602.2	752.8
	200	48.6	64.8	97.2	113.4	145.8	178.3	243.4	292.0	324.4	405.4	470.3	583.8	729.8
	250	46.3	61.8	92.7	108.1	139.0	169.9	231.8	278.1	309.0	386.2	447.9	555.9	694.8
	300	42.9	57.2	85.7	100.0	128.6	157.2	214.4	257.2	285.8	357.1	414.2	514.1	642.6
	325	41.4	55.1	82.6	96.4	124.0	151.5	206.6	247.9	275.5	344.3	399.4	495.7	619.6
	350	40.3	53.7	80.4	93.8	120.7	147.5	201.1	241.4	268.2	335.3	388.9	482.7	603.3
	375	38.9	51.8	77.6	90.6	116.5	142.4	194.1	232.8	258.7	323.2	374.9	465.4	581.8
	400	36.5	48.8	73.3	85.5	109.8	134.2	183.1	219.6	244.0	304.9	353.6	438.9	548.5
	425	35.2	46.8	70.0	81.7	105.1	128.4	175.1	210.1	233.4	291.6	338.2	419.8	524.7
	450	33.7	45.0	67.7	78.9	101.4	123.9	169.0	202.8	225.4	281.8	326.8	405.7	507.0
	475	31.7	42.3	63.4	74.0	95.1	116.1	158.2	189.9	211.1	263.9	306.1	379.9	474.8
	500	28.2	37.6	56.5	65.9	84.7	103.4	140.9	169.1	188.0	235.0	272.6	338.4	423.0
	538	18.4	24.6	36.9	43.0	55.3	67.6	92.2	110.7	123.0	153.7	178.3	221.3	276.6
	550	15.6	20.8	31.3	36.5	46.9	57.3	78.2	93.8	104.3	130.3	151.1	187.6	234.5
	575	10.5	14.0	21.1	24.6	31.6	38.6	52.6	63.1	70.2	87.7	101.7	126.3	157.9
	595	7.6	10.2	15.3	17.8	22.9	27.9	38.0	45.7	50.8	63.5	73.6	91.4	114.2
ASTM A-217-WC9 SPECIAL CLASS (1)	-29 to 38	51.7	68.9	103.4	120.6	155.1	189.6	258.6	310.3	344.8	430.9	499.9	620.5	775.7
	50	51.7	68.9	103.4	120.6	155.1	189.6	258.6	310.3	344.8	430.9	499.9	620.5	775.7
	100	51.6	68.8	103.2	120.4	154.9	189.3	258.1	309.7	344.2	430.2	499.0	619.5	774.3
	150	51.0	68.0	101.9	118.9	152.9	186.9	254.8	305.7	339.7	424.6	492.5	611.4	764.3
	200	50.2	66.9	100.4	117.2	150.7	184.2	251.1	301.3	334.8	418.5	485.5	602.7	753.4
	250	50.0	66.7	100.0	116.6	149.9	183.2	249.9	299.9	333.2	416.5	483.1	599.8	749.7
	300	49.8	66.4	99.6	116.2	149.3	182.5	248.9	298.7	331.9	414.8	481.2	597.3	746.7
	325	49.6	66.1	99.2	115.7	148.8	181.9	248.0	297.6	330.7	413.3	479.4	595.1	743.9
	350	49.2	65.6	98.4	114.8	147.6	180.4	246.0	295.2	328.0	410.0	475.6	590.5	738.1
	375	48.8	65.0	97.5	113.8	146.3	178.8	243.8	292.6	325.1	406.3	471.3	585.1	731.3
	400	48.8	65.0	97.5	113.8	146.3	178.8	243.8	292.6	325.1	406.3	471.3	585.1	731.3
	425	48.8	65.0	97.5	113.8	146.3	178.8	243.8	292.6	325.1	406.3	471.3	585.1	731.3
	450	47.3	63.0	94.4	110.1	141.4	172.9	235.8	283.0	314.5	393.1	456.0	566.1	707.6
	475	42.8	57.0	85.5	99.7	128.2	156.7	213.7	256.5	285.0	356.3	413.3	513.1	641.3
	500	35.6	47.6	71.5	83.4	107.1	130.9	178.6	214.3	238.1	297.5	345.1	428.3	535.4
	538	23.0	30.7	46.1	53.8	69.1	84.5	115.2	138.3	153.7	192.1	222.8	276.6	345.7
	550	19.5	26.0	39.1	45.6	58.6	71.6	97.7	117.2	130.3	162.8	188.9	234.5	293.1
	575	13.2	17.6	26.3	30.7	39.5	48.3	65.8	79.0	87.8	109.7	127.2	157.9	197.4
	595	9.5	12.7	19.0	22.2	28.5	34.9	47.6	57.1	63.4	79.3	92.0	114.2	142.8

IMPORTANT: The above ratings are only for reference. Refer to ASME B16.34 for pressure/temperature ratings.

1. Shaded ratings may require special trim and packing. Consult your Flowserve sales representative for applications in these ranges.

*Pressure temperature ratings are from ASME B16.34 "Valves, Flanged, Threaded and Welding Ends." Consult your Flowserve sales representative for pressure temperature ratings of materials not included in this catalog.



Reference: ASME B16.34 – 2004 Pressure/Temperature Ratings

Cast Steel* (Gate, Globe & Check Valves)

RATING	TEMP. °F	PRESSURE (PSIG)												
		300	400	600	700	900	1100	1500	1800	2000	2500	2900	3600	4500
ASTM A217-C12A STANDARD CLASS	-20 to 100	750	1000	1500	1750	2250	2750	3750	4500	5000	6250	7250	9000	11250
	200	750	1000	1500	1750	2250	2750	3750	4500	5000	6250	7250	9000	11250
	300	730	970	1455	1700	2185	2670	3640	4370	4855	6070	7040	8740	10925
	400	705	940	1410	1645	2115	2585	3530	4235	4705	5880	6820	8470	10585
	500	665	885	1330	1550	1995	2440	3325	3990	4435	5540	6425	7975	9965
	600	605	805	1210	1410	1815	2220	3025	3630	4035	5040	5845	7255	9070
	650	590	785	1175	1370	1765	2155	2940	3530	3925	4905	5690	7060	8825
	700	570	760	1135	1325	1705	2085	2840	3405	3785	4730	5485	6810	8515
	750	530	710	1065	1240	1595	1950	2660	3190	3545	4430	5140	6375	7970
	800	510	680	1015	1185	1525	1865	2540	3045	3385	4230	4905	6090	7610
	850	485	650	975	1135	1460	1785	2435	2925	3250	4060	4710	5845	7305
	900	450	600	900	1050	1350	1650	2245	2695	2995	3745	4345	5390	6740
	950	385	515	775	905	1160	1415	1930	2315	2575	3220	3735	4635	5795
	1000	365	485	725	845	1090	1335	1820	2185	2425	3030	3515	4360	5450
	1050	360	480	720	840	1080	1320	1800	2160	2400	3000	3480	4320	5400
	1100	300	400	605	705	905	1105	1510	1810	2015	2515	2915	3620	4525
	1150	225	300	445	520	670	820	1115	1335	1485	1855	2155	2675	3345
	1200	145	195	290	335	430	525	720	865	960	1200	1390	1730	2160
ASTM A217-C12A SPECIAL CLASS	-20 to 100	750	1000	1500	1750	2250	2750	3750	4500	5000	6250	7250	9000	11250
	200	750	1000	1500	1750	2250	2750	3750	4500	5000	6250	7250	9000	11250
	300	750	1000	1500	1750	2250	2750	3750	4500	5000	6250	7250	9000	11250
	400	750	1000	1500	1750	2250	2750	3750	4500	5000	6250	7250	9000	11250
	500	750	1000	1500	1750	2250	2750	3750	4500	5000	6250	7250	9000	11250
	600	750	1000	1500	1750	2250	2750	3750	4500	5000	6250	7250	9000	11250
	650	750	1000	1500	1750	2250	2750	3750	4500	5000	6250	7250	9000	11250
	700	735	980	1465	1710	2200	2690	3665	4400	4890	6110	7085	8795	10995
	750	730	975	1460	1700	2185	2670	3645	4375	4860	6070	7040	8745	10930
	800	720	960	1440	1680	2160	2640	3600	4320	4800	6000	6960	8640	10800
	850	680	905	1355	1580	2030	2480	3385	4065	4515	5645	6550	8130	10160
	900	600	800	1200	1400	1800	2200	3000	3600	4000	5000	5800	7200	9000
	950	470	630	945	1100	1415	1730	2360	2830	3145	3930	4560	5655	7070
	1000	420	560	840	980	1260	1540	2105	2525	2805	3505	4065	5050	6310
	1050	420	560	840	980	1260	1540	2105	2525	2805	3505	4065	5050	6310
	1100	375	500	755	880	1130	1380	1885	2265	2515	3145	3645	4525	5655
	1150	280	370	555	650	835	1020	1395	1675	1860	2320	2690	3345	4180
	1200	180	240	360	420	540	660	900	1080	1200	1500	1740	2160	2700

IMPORTANT: The above ratings are only for reference. Refer to ASME B16.34 for pressure/temperature ratings.

Shaded ratings may require special trim or packing. Consult your Flowserve sales representative for applications in these ranges.

*Pressure temperature ratings are from ASME B16.34 "Valves, Flanged, Threaded and Welding Ends."

Consult your Edward Valves sales representative for pressure temperature ratings of materials not included in this catalog.

**Series 4500 rated Cast Steel Valves do not comply with ASME Class 4500 ratings. Consult your Flowserve sales representative for pressure temperature ratings of these valves. See 3.2 Pressure Ratings in the Technical Information section for additional information.

Reference: ASME B16.34 – 2004 Pressure/Temperature Ratings (metric)

Cast Steel* (Gate, Globe & Check Valves)

1 bar = 100 kPa = 14.50 ps

RATING	TEMP. °C	PRESSURE (BAR)												
		300	400	600	700	900	1100	1500	1800	2000	2500	2900	3600	4500
ASTM A-217-C12A STANDARD CLASS	-29 to 38	51.7	68.9	103.4	120.6	155.1	189.6	258.6	310.3	344.8	430.9	499.9	620.5	775.7
	50	51.7	68.9	103.4	120.6	155.1	189.6	258.6	310.3	344.8	430.9	499.9	620.5	775.7
	100	51.5	68.7	103.0	120.2	154.6	188.9	257.6	309.1	343.5	429.4	498.1	618.4	773.0
	150	50.3	67.0	100.3	117.1	150.6	184.0	250.8	301.0	334.5	418.2	485.1	602.2	752.8
	200	48.6	64.8	97.2	113.4	145.8	178.3	243.4	292.0	324.4	405.4	470.3	583.8	729.8
	250	46.3	61.8	92.7	108.1	139.0	169.9	231.8	278.1	309.0	386.2	447.9	555.9	694.8
	300	42.9	57.2	85.7	100.0	128.6	157.2	214.4	257.2	285.8	357.1	414.2	514.1	642.6
	325	41.4	55.1	82.6	96.4	124.0	151.5	206.6	247.9	275.5	344.3	399.4	495.7	619.6
	350	40.3	53.7	80.4	93.8	120.7	147.5	201.1	241.4	268.2	335.3	388.9	482.7	603.3
	375	38.9	51.8	77.6	90.6	116.5	142.4	194.1	232.8	258.7	323.2	374.9	465.4	581.8
	400	36.5	48.8	73.3	85.5	109.8	134.2	183.1	219.6	244.0	304.9	353.6	438.9	548.5
	425	35.2	46.8	70.0	81.7	105.1	128.4	175.1	210.1	233.4	291.6	338.2	419.8	524.7
	450	33.7	45.0	67.7	78.9	101.4	123.9	169.0	202.8	225.4	281.8	326.8	405.7	507.0
	475	31.7	42.3	63.4	74.0	95.1	116.1	158.2	189.9	211.1	263.9	306.1	379.9	474.8
	500	28.2	37.6	56.5	65.9	84.7	103.4	140.9	169.1	188.0	235.0	272.6	338.4	423.0
	538	25.2	33.5	50.0	58.4	75.2	92.0	125.5	150.5	167.2	208.9	242.3	300.7	375.8
	550	25.0	33.3	49.8	58.1	74.8	91.5	124.9	149.8	166.5	208.0	241.2	299.4	374.2
	575	24.0	32.0	47.9	55.9	71.8	87.8	119.7	143.6	159.6	199.5	231.4	287.3	359.1
	600	19.5	26.0	39.0	45.5	58.5	71.5	97.5	117.0	130.0	162.5	188.5	234.0	292.5
	625	14.6	19.5	29.2	34.1	43.8	53.5	73.0	87.6	97.4	121.7	141.2	175.3	219.1
650	9.9	13.2	19.9	23.2	29.8	36.4	49.6	59.5	66.2	82.7	95.9	119.1	148.9	
ASTM A-217-C12A SPECIAL CLASS	-29 to 38	51.7	68.9	103.4	120.6	155.1	189.6	258.6	310.3	344.8	430.9	499.9	620.5	775.7
	50	51.7	68.9	103.4	120.6	155.1	189.6	258.6	310.3	344.8	430.9	499.9	620.5	775.7
	100	51.7	68.9	103.4	120.6	155.1	189.6	258.6	310.3	344.8	430.9	499.9	620.5	775.7
	150	51.7	68.9	103.4	120.6	155.1	189.6	258.6	310.3	344.8	430.9	499.9	620.5	775.7
	200	51.7	68.9	103.4	120.6	155.1	189.6	258.6	310.3	344.8	430.9	499.9	620.5	775.7
	250	51.7	68.9	103.4	120.6	155.1	189.6	258.6	310.3	344.8	430.9	499.9	620.5	775.7
	300	51.7	68.9	103.4	120.6	155.1	189.6	258.6	310.3	344.8	430.9	499.9	620.5	775.7
	325	51.7	68.9	103.4	120.6	155.1	189.6	258.6	310.3	344.8	430.9	499.9	620.5	775.7
	350	51.5	68.6	102.8	120.0	154.3	188.6	257.1	308.6	342.9	428.6	497.2	617.1	771.4
	375	50.6	67.4	101.0	117.8	151.5	185.2	252.5	303.0	336.7	420.9	488.2	606.0	757.4
	400	50.3	67.1	100.6	117.3	150.6	184.1	251.2	301.3	334.8	418.3	485.3	602.5	753.2
	425	49.6	66.2	99.3	115.8	148.9	182.0	248.2	297.9	331.0	413.7	479.9	595.7	744.6
	450	47.3	63.0	94.4	110.1	141.4	172.9	235.8	283.0	314.5	393.1	456.0	566.1	707.6
	475	42.8	57.0	85.5	99.7	128.2	156.7	213.7	256.5	285.0	356.3	413.3	513.1	641.3
	500	35.6	47.6	71.5	83.4	107.1	130.9	178.6	214.3	238.1	297.5	345.1	428.3	535.4
	538	29.0	38.6	57.9	67.6	86.9	106.3	145.1	174.1	193.4	241.7	280.4	348.1	435.1
	550	29.0	38.6	57.9	67.6	86.9	106.3	145.1	174.1	193.4	241.7	280.4	348.1	435.1
	575	28.6	38.1	57.1	66.6	85.7	104.8	143.0	171.6	190.7	238.3	276.4	343.1	428.8
	600	24.4	32.5	48.7	56.8	73.1	89.4	121.9	146.3	162.5	203.1	235.6	292.5	365.6
	625	18.3	24.4	36.5	42.6	54.8	67.0	91.3	109.5	121.7	152.1	176.4	219.0	273.8
650	12.4	16.5	24.8	28.9	37.2	45.5	62.1	74.5	82.8	103.4	120.0	148.9	186.2	

IMPORTANT: The above ratings are only for reference. Refer to ASME B16.34 for pressure/temperature ratings.

Shaded ratings may require special trim or packing. Consult your Flowserve sales representative for applications in these ranges.

*Pressure temperature ratings are from ASME B16.34 "Valves, Flanged, Threaded and Welding Ends."

Consult your Flowserve sales representative for pressure temperature ratings of materials not included in this catalog.



Reference: ASME B16.34 – 2004 Pressure/Temperature Ratings

Cast Steel* (Gate, Globe & Check Valves)

RATING	TEMP. °F	PRESSURE (PSIG)												
		300	400	600	700	900	1100	1500	1800	2000	2500	2900	3600	4500
ASTM A351-CF8M STANDARD CLASS (1)	-20 to 100	720	960	1440	1680	2160	2640	3600	4320	4800	6000	6960	8640	10800
	200	620	825	1240	1445	1860	2270	3095	3715	4130	5160	5985	7430	9290
	300	560	745	1120	1305	1680	2050	2795	3355	3730	4660	5405	6710	8390
	400	515	685	1025	1195	1540	1885	2570	3085	3425	4280	4965	6165	7705
	500	480	640	955	1115	1435	1755	2390	2865	3185	3980	4615	5730	7165
	600	450	600	900	1050	1355	1655	2255	2705	3010	3760	4360	5415	6770
	650	440	590	885	1030	1325	1620	2210	2650	2945	3680	4270	5300	6625
	700	435	580	870	1015	1305	1595	2170	2605	2895	3620	4200	5210	6515
	750	425	570	855	995	1280	1565	2135	2565	2850	3560	4130	5130	6410
	800	420	560	845	985	1265	1545	2110	2535	2815	3520	4085	5070	6335
	850	420	560	835	975	1255	1535	2090	2505	2785	3480	4035	5010	6265
	900	415	555	830	970	1245	1520	2075	2490	2770	3460	4015	4985	6230
	950	385	515	775	905	1160	1415	1930	2315	2575	3220	3735	4635	5795
	1000	365	485	725	845	1090	1335	1820	2185	2425	3030	3515	4360	5450
	1050	360	480	720	840	1080	1320	1800	2160	2400	3000	3480	4320	5400
	1100	305	405	610	710	915	1120	1525	1830	2035	2545	2950	3660	4575
	1150	235	315	475	555	710	870	1185	1420	1580	1970	2285	2840	3550
	1200	185	245	370	430	555	680	925	1110	1235	1545	1790	2220	2775
	1250	145	195	295	345	440	540	735	885	985	1230	1425	1770	2210
	1300	115	155	235	275	350	430	585	700	780	970	1125	1400	1750
1350	95	125	190	225	290	355	480	575	640	800	930	1150	1440	
1400	75	100	150	175	225	275	380	455	505	630	730	905	1130	
1450	60	80	115	135	175	215	290	350	390	485	565	700	875	
1500	40	55	85	100	125	150	205	245	275	345	400	495	620	

IMPORTANT: The above ratings are only for reference. Refer to ASME B16.34 for pressure/temperature ratings.

1. Shaded ratings may require special trim and packing, consult your Flowserve representative for applications in these ranges.

*Pressure temperature ratings are from ASME B16.34 "Valves, Flanged, Threaded and Welding Ends."

Consult your Flowserve sales representative for pressure temperature ratings of materials not included in this catalog.

**Series 4500 rated Cast Steel Valves do not comply with ASME Class 4500 ratings. Consult your Flowserve sales representative for pressure temperature ratings of these valves. See 3.2 Pressure Ratings in the Technical Information section, for additional information.

Reference: ASME B16.34 – 2004 Pressure/Temperature Ratings

Cast Steel* (Gate, Globe & Check Valves)

RATING	TEMP. °F	PRESSURE (PSIG)												
		300	400	600	700	900	1100	1500	1800	2000	2500	2900	3600	4500
ASTM A351-CF8M SPECIAL CLASS (1)	-20 to 100	750	1000	1500	1750	2250	2750	3750	4500	5000	6250	7250	9000	11250
	200	690	920	1380	1610	2075	2535	3455	4145	4610	5760	6680	8295	10365
	300	625	835	1250	1455	1870	2285	3120	3745	4160	5200	6030	7490	9360
	400	575	765	1145	1335	1720	2100	2865	3440	3820	4775	5540	6880	8600
	500	535	710	1065	1245	1600	1955	2665	3200	3555	4440	5150	6395	7995
	600	505	670	1005	1175	1510	1845	2520	3025	3360	4195	4865	6045	7555
	650	495	660	985	1150	1480	1810	2465	2955	3285	4105	4765	5915	7395
	700	485	645	970	1130	1455	1780	2425	2910	3235	4040	4685	5815	7270
	750	475	635	955	1115	1430	1750	2385	2860	3180	3975	4610	5720	7150
	800	470	630	945	1100	1415	1730	2355	2830	3145	3930	4560	5655	7070
	850	465	620	930	1085	1400	1710	2330	2795	3110	3885	4505	5595	6990
	900	465	620	925	1080	1390	1700	2315	2780	3090	3860	4480	5560	6950
	950	460	610	915	1070	1375	1680	2290	2750	3055	3815	4425	5495	6870
	1000	420	560	840	980	1260	1540	2105	2525	2805	3505	4065	5050	6310
	1050	420	560	840	980	1260	1540	2105	2525	2805	3505	4065	5050	6310
	1100	380	510	765	890	1145	1400	1905	2290	2545	3180	3690	4575	5720
	1150	295	395	590	690	885	1085	1480	1775	1975	2465	2860	3550	4435
	1200	230	310	465	540	695	850	1155	1390	1545	1930	2240	2775	3470
	1250	185	245	370	430	555	675	920	1105	1230	1535	1780	2210	2765
	1300	145	195	290	340	435	535	730	875	975	1215	1410	1750	2185
1350	120	160	240	280	360	440	600	720	800	1000	1160	1440	1800	
1400	95	125	190	220	285	345	470	565	630	785	910	1130	1415	
1450	75	100	145	170	220	270	365	435	485	605	705	875	1095	
1500	50	70	105	120	155	190	260	310	345	430	500	615	770	

IMPORTANT: The above ratings are only for reference. Refer to ASME B16.34 for pressure/temperature ratings.

1. Shaded ratings may require special trim and packing, consult your Flowserve representative for applications in these ranges.

* Pressure temperature ratings are from ASME B16.34 "Valves, Flanged, Threaded and Welding Ends." Consult your Flowserve sales representative for pressure temperature ratings of materials not included in this catalog.

** Series 4500 rated Cast Steel Valves do not comply with ASME Class 4500 ratings. Consult your Flowserve sales representative for pressure temperature ratings of these valves. See 3.2 Pressure Ratings in the Technical Information section, for additional information.



Reference: ASME B16.34 – 2004 Pressure/Temperature Ratings (metric)

Cast Steel* (Gate, Globe & Check Valves)

1 bar = 100 kPa = 14.50 psi

RATING	TEMP. °C	PRESSURE (BAR)												
		300	400	600	700	900	1100	1500	1800	2000	2500	2900	3600	4500
ASTM A351-CF8M STANDARD CLASS (1)	-29 to 38	49.6	66.2	99.3	115.8	148.9	182.0	248.2	297.9	331.0	413.7	479.9	595.7	744.6
	50	48.1	64.1	96.2	112.2	144.3	176.4	240.6	288.7	320.8	400.9	465.1	577.3	721.7
	100	42.2	56.3	84.4	98.5	126.6	154.7	211.0	253.2	281.3	351.6	407.9	506.3	632.9
	150	38.5	51.3	77.0	89.8	115.5	141.2	192.5	231.0	256.7	320.8	372.1	461.9	577.4
	200	35.7	47.6	71.3	83.2	107.0	130.8	178.3	214.0	237.8	297.2	344.7	427.9	534.9
	250	33.4	44.5	66.8	77.9	100.1	122.4	166.9	200.3	222.5	278.1	322.6	400.5	500.6
	300	31.6	42.1	63.2	73.8	94.9	116.0	158.1	189.7	210.8	263.5	305.7	379.4	474.3
	325	30.9	41.2	61.8	72.1	92.7	113.3	154.4	185.3	205.9	257.4	298.6	370.6	463.3
	350	30.3	40.4	60.7	70.8	91.0	111.2	151.6	181.9	202.2	252.7	293.1	363.9	454.9
	375	29.9	39.9	59.8	69.7	89.6	109.5	149.4	179.3	199.2	249.0	288.8	358.6	448.2
	400	29.4	39.2	58.9	68.7	88.3	107.9	147.2	176.6	196.3	245.3	284.6	353.3	441.6
	425	29.1	38.8	58.3	68.0	87.4	106.8	145.7	174.9	194.3	242.9	281.7	349.7	437.1
	450	28.8	38.4	57.7	67.3	86.5	105.7	144.2	173.1	192.3	240.4	278.9	346.2	432.7
	475	28.7	38.2	57.3	66.9	86.0	105.1	143.4	172.1	191.2	238.9	277.1	344.1	430.1
	500	28.2	37.6	56.5	65.9	84.7	103.4	140.9	169.1	188.0	235.0	272.6	338.4	423.0
	538	25.2	33.5	50.0	58.4	75.2	92.0	125.5	150.5	167.2	208.9	242.3	300.7	375.8
	550	25.0	33.3	49.8	58.1	74.8	91.5	124.9	149.8	166.5	208.0	241.2	299.4	374.2
	575	24.0	32.0	47.9	55.9	71.8	87.8	119.7	143.6	159.6	199.5	231.4	287.3	359.1
	600	19.9	26.5	39.8	46.4	59.7	73.0	99.5	119.4	132.7	165.9	192.4	238.9	298.6
	625	15.8	21.1	31.6	36.9	47.4	58.0	79.1	94.9	105.5	131.8	152.9	189.8	237.2
650	12.7	16.9	25.3	29.5	38.0	46.4	63.3	76.0	84.4	105.5	122.4	151.9	189.9	
675	10.3	13.7	20.6	24.1	31.0	37.9	51.6	61.9	68.8	86.0	99.8	123.8	154.8	
700	8.4	11.2	16.8	19.6	25.1	30.7	41.9	50.3	55.9	69.8	81.0	100.5	125.7	
725	7.0	9.3	14.0	16.3	21.0	25.6	34.9	41.9	46.6	58.2	67.5	83.8	104.8	
750	5.9	7.8	11.7	13.7	17.6	21.5	29.3	35.2	39.1	48.9	56.7	70.4	87.9	
775	4.6	6.1	9.0	10.6	13.7	16.7	22.8	27.4	30.4	38.0	44.1	54.7	68.4	
800	3.5	4.7	7.0	8.2	10.5	12.8	17.4	20.9	23.3	29.2	33.9	42.1	52.6	
816	2.8	3.8	5.9	6.8	8.6	10.4	14.1	17.0	19.0	23.8	27.6	34.2	42.7	

IMPORTANT: The above ratings are only for reference. Refer to ASME B16.34 for pressure/temperature ratings.

1. Shaded ratings may require special trim and packing, consult your Flowserve representative for applications in these ranges.

*Pressure temperature ratings are from ASME B16.34 "Valves, Flanged, Threaded and Welding Ends."

Consult your Flowserve sales representative for pressure temperature ratings of materials not included in this catalog.

Reference: ASME B16.34 – 2004 Pressure/Temperature Ratings (metric)

Cast Steel* (Gate, Globe & Check Valves)

1 bar = 100 kPa = 14.50 psi

RATING	TEMP. °C	PRESSURE (BAR)												
		300	400	600	700	900	1100	1500	1800	2000	2500	2900	3600	4500
ASTM A351-CF8M SPECIAL CLASS (1)	-29 to 38	51.7	68.9	103.4	120.6	155.1	189.6	258.6	310.3	344.8	430.9	499.9	620.5	775.7
	50	50.8	67.7	101.6	118.6	152.5	186.4	254.1	304.9	338.8	423.5	491.3	609.8	762.3
	100	47.1	62.8	94.2	109.9	141.3	172.7	235.5	282.6	314.0	392.4	455.2	565.1	706.4
	150	43.0	57.3	85.9	100.2	128.9	157.5	214.8	257.8	286.4	358.0	415.3	515.5	644.4
	200	39.8	53.1	79.6	92.9	119.4	145.9	199.0	238.8	265.4	331.7	384.8	477.6	597.0
	250	37.3	49.7	74.5	86.9	111.8	136.6	186.3	223.5	248.4	310.4	360.1	447.0	558.8
	300	35.3	47.1	70.6	82.4	105.9	129.4	176.4	211.7	235.3	294.1	341.1	423.5	529.3
	325	34.5	46.0	68.9	80.4	103.4	126.4	172.3	206.8	229.8	287.2	333.2	413.6	517.0
	350	33.8	45.1	67.7	79.0	101.5	124.1	169.2	203.1	225.7	282.1	327.2	406.2	507.7
	375	33.3	44.4	66.7	77.8	100.0	122.2	166.7	200.1	222.3	277.9	322.4	400.2	500.2
	400	32.9	43.8	65.7	76.7	98.6	120.5	164.3	197.2	219.1	273.8	317.6	394.3	492.9
	425	32.5	43.4	65.1	75.9	97.6	119.3	162.6	195.2	216.9	271.1	314.5	390.3	487.9
	450	32.2	42.9	64.4	75.1	96.6	118.1	161.0	193.2	214.7	268.3	311.2	386.3	482.9
	475	32.0	42.7	64.0	74.7	96.0	117.3	160.0	192.0	213.3	266.6	309.3	384.0	480.0
	500	31.7	42.3	63.4	74.0	95.1	116.3	158.6	190.3	211.5	264.3	306.6	380.6	475.7
	538	29.0	38.6	57.9	67.6	86.9	106.3	145.1	174.1	193.4	241.7	280.4	348.1	435.1
	550	29.0	38.6	57.9	67.6	86.9	106.3	145.1	174.1	193.4	241.7	280.4	348.1	435.1
	575	28.6	38.1	57.1	66.6	85.7	104.8	143.0	171.6	190.7	238.3	276.4	343.1	428.8
	600	24.9	33.2	49.8	58.1	74.6	91.2	124.4	149.3	165.9	207.3	240.5	298.5	373.2
	625	19.8	26.4	39.5	46.1	59.3	72.5	98.8	118.6	131.8	164.7	191.1	237.2	296.5
650	15.8	21.1	31.7	37.0	47.5	58.0	79.1	94.9	105.5	131.9	153.0	189.9	237.4	
675	12.9	17.2	25.8	30.1	38.7	47.3	64.5	77.4	86.0	107.5	124.7	154.8	193.5	
700	11.4	15.2	22.8	26.6	34.3	41.9	57.1	68.5	76.2	95.2	110.4	137.1	171.3	
725	9.5	12.7	19.1	22.3	28.6	35.0	47.7	57.2	63.6	79.5	92.2	114.4	143.0	
750	7.4	9.9	14.8	17.2	22.1	27.0	36.7	44.1	49.0	61.2	71.0	88.2	110.3	
775	5.8	7.7	11.4	13.3	17.2	21.0	28.5	34.2	38.1	47.6	55.2	68.5	85.6	
800	4.4	5.9	8.8	10.3	13.2	16.1	22.0	26.4	29.3	36.6	42.4	52.6	65.6	
816	3.4	4.7	7.2	8.4	10.7	13.1	17.9	21.4	23.8	29.6	34.3	42.5	53.1	

IMPORTANT: The above ratings are only for reference. Refer to ASME B16.34 for pressure/temperature ratings.

1. Shaded ratings may require special trim and packing, consult your Flowserve representative for applications in these ranges.

* Pressure temperature ratings are from ASME B16.34 "Valves, Flanged, Threaded and Welding Ends."

Consult your Flowserve sales representative for pressure temperature ratings of materials not included in this catalog.



Reference: ASME B16.34 – 2004 Pressure/Temperature Ratings

Cast Steel* (Gate, Globe & Check Valves)

RATING	TEMP. °F	PRESSURE (PSIG)												
		300	400	600	700	900	1100	1500	1800	2000	2500	2900	3600	4500
A 351 Gr. CF8C GROUP 2.11 STANDARD CLASS (1) (2)	100	275	660	1,440	1,680	2,160	2,640	3,600	4,320	4,800	6,000	6,960	8,640	10,800
	200	255	610	1,325	1,545	1,985	2,430	3,310	3,975	4,415	5,520	6,400	7,950	9,935
	300	230	565	1,235	1,440	1,850	2,260	3,085	3,700	4,115	5,140	5,900	7,400	9,250
	400	200	520	1,150	1,340	1,730	2,115	2,880	3,455	3,840	4,800	5,570	6,910	8,640
	500	170	475	1,085	1,265	1,625	1,990	2,710	3,250	3,615	4,520	5,240	6,510	8,135
	600	140	440	1,030	1,200	1,550	1,895	2,580	3,095	3,440	4,300	4,990	6,190	7,740
	650	125	420	1,015	1,180	1,520	1,860	2,530	3,040	3,375	4,220	4,895	6,075	7,595
	700	110	405	995	1,160	1,490	1,820	2,485	2,980	3,315	4,140	4,800	5,960	7,450
	750	95	390	985	1,150	1,475	1,800	2,460	2,950	3,280	4,100	4,755	5,905	7,380
	800	80	380	975	1,140	1,460	1,785	2,435	2,925	3,250	4,060	4,710	5,850	7,310
	850	65	370	970	1,130	1,455	1,780	2,425	2,910	3,235	4,040	4,685	5,820	7,270
	900	50	330	900	1,050	1,350	1,650	2,245	2,695	2,995	3,745	4,345	5,390	6,740
	950	35	280	775	900	1,160	1,420	1,930	2,320	2,575	3,220	3,735	4,635	5,795
	1000	20	255	725	850	1,090	1,335	1,820	2,180	2,425	3,030	3,515	4,360	5,450
	1050	20	250	720	840	1,080	1,320	1,800	2,160	2,400	3,000	3,480	4,320	5,400
	1100	20	220	625	730	935	1,145	1,560	1,870	2,080	2,600	3,015	3,745	4,680
	1150	20	150	420	490	625	765	1,045	1,255	1,395	1,745	2,025	2,510	3,135
	1200	20	115	300	350	455	555	755	905	1,005	1,255	1,560	1,810	2,265
	1250	20	90	225	265	340	415	565	380	755	945	1,095	1,360	1,695
	1300	20	60	150	175	225	275	375	450	500	630	730	905	1,130
1350	20	50	105	120	155	190	255	310	345	430	500	620	770	
1400	15	40	80	95	125	150	205	250	275	345	400	495	615	
1450	10	30	60	70	95	115	155	185	205	255	300	370	465	
1500	10	25	55	65	80	100	135	165	185	230	265	330	410	
A 351 Gr. CF8C GROUP 2.11 SPECIAL CLASS (1) (2)	100	290	695	1,500	1,750	2,250	2,750	3,750	4,500	5,000	6,250	7,250	9,000	11,250
	200	275	660	1,435	1,675	2,150	2,630	3,585	4,300	4,780	5,975	6,930	8,600	10,750
	300	255	610	1,320	1,540	1,975	2,415	3,295	3,955	4,395	5,490	6,370	7,910	9,885
	400	240	575	1,245	1,450	1,865	2,280	3,105	3,730	4,145	5,180	6,010	7,460	9,320
	500	230	550	1,200	1,400	1,800	2,200	3,000	3,600	4,000	5,000	5,800	7,200	9,000
	600	220	530	1,150	1,340	1,730	2,115	2,880	3,455	3,840	4,800	5,570	6,910	8,640
	650	215	520	1,130	1,320	1,695	2,070	2,825	3,390	3,770	4,710	5,465	6,785	8,480
	700	215	515	1,110	1,295	1,665	2,030	2,770	3,325	3,695	4,620	5,360	6,650	8,315
	750	210	510	1,100	1,280	1,645	2,010	2,745	3,295	3,660	4,575	5,310	6,590	8,235
	800	210	505	1,090	1,270	1,630	1,995	2,720	3,265	3,625	4,530	5,255	6,525	8,155
	850	205	500	1,080	1,260	1,625	1,985	2,705	3,250	3,610	4,510	5,230	6,495	8,115
	900	205	500	1,080	1,260	1,625	1,985	2,705	3,250	3,610	4,510	5,230	6,490	8,115
	950	180	435	945	1,100	1,415	1,730	2,360	2,830	3,145	3,930	4,560	5,660	7,070
	1000	160	390	840	980	1,260	1,540	2,105	2,525	2,805	3,505	4,065	5,050	6,310
	1050	160	390	840	980	1,260	1,540	2,105	2,525	2,805	3,505	4,065	5,048	6,310
	1100	150	360	780	910	1,170	1,430	1,950	2,340	2,600	3,250	3,770	4,680	5,850
	1150	100	240	525	610	785	960	1,305	1,570	1,745	2,180	2,530	3,137	3,920
	1200	70	170	375	440	565	690	945	1,135	1,260	1,570	1,820	2,263	2,830
	1250	55	130	285	330	425	520	705	850	945	1,180	1,370	1,697	2,120
	1300	35	90	190	220	285	350	470	565	630	785	910	1,132	1,415
1350	25	60	130	150	195	240	320	385	430	535	620	772	965	
1400	20	50	105	120	155	190	255	310	345	430	500	617	770	
1450	15	35	75	90	115	140	195	230	260	320	370	463	580	
1500	15	35	70	80	105	130	170	205	230	285	330	412	515	

IMPORTANT: The above ratings are only for reference. Refer to ASME B16.34 for pressure/temperature ratings.

Note: Flanged End Valve ratings are limited to standard class only and terminate at 1000°F.

1. Permissible but not recommended for prolonged use at temperatures above approx. 800°F.

2. Shaded ratings may require special trim and packing. Consult your Edward Valves sales representative for applications in these ranges.

* Pressure temperature ratings are from ASME B16.34 "Valves, Flanged, Threaded and Welding Ends." Consult your Flowserve sales representative for pressure temperature ratings of materials not included in this catalog.

** Series 4500 rated Cast Steel Valves do not comply with ASME Class 4500 ratings. Consult your Flowserve sales representative for pressure temperature ratings of these valves. See 3.2 Pressure Ratings in the Technical Information section for additional information.

Reference: ASME B16.34 – 2004 Pressure/Temperature Ratings (metric)
Cast Steel* (Gate, Globe & Check Valves) 1 bar = 100 kPa = 14.50 psi

RATING	TEMP. °C	PRESSURE (BAR)												
		300	400	600	700	900	1100	1500	1800	2000	2500	2900	3600	4500
A 351 Gr. CF8C GROUP 2.11 STANDARD CLASS (1) (2)	38	49.6	66.2	99.3	115.8	148.9	182.0	248.2	297.9	331.0	413.7	479.9	595.7	744.6
	50	48.8	65.0	97.5	113.8	146.3	178.8	243.8	292.6	325.1	406.4	471.4	585.2	731.5
	100	45.3	60.4	90.6	105.7	135.9	166.1	226.5	259.8	282.0	337.4	405.8	525.5	679.4
	150	42.5	53.3	74.8	92.3	127.4	155.7	212.4	254.9	283.2	353.9	410.5	509.7	637.1
	200	39.9	53.2	79.9	93.2	119.8	146.4	199.7	239.6	266.3	332.8	386.1	479.3	599.1
	250	37.8	50.4	75.6	88.2	113.4	138.6	189.1	226.9	252.1	315.1	365.5	453.8	567.2
	300	36.1	48.1	72.2	84.2	108.3	132.3	180.4	216.5	240.6	300.7	348.8	433.0	541.3
	325	35.4	47.2	70.7	82.5	106.1	129.7	176.8	212.1	235.7	294.6	341.7	424.2	530.3
	350	34.8	46.4	69.5	81.1	104.3	127.5	173.8	208.5	231.7	289.6	335.9	417.0	521.3
	375	34.2	45.6	68.4	79.8	102.6	125.4	171.0	205.2	228.1	285.1	330.7	410.5	513.1
	400	33.9	45.2	67.8	79.1	101.7	124.3	169.5	203.4	226.1	282.6	327.8	406.9	508.6
	425	33.6	44.8	67.2	78.4	100.8	123.2	168.1	201.7	224.1	280.1	324.9	403.4	504.2
	450	33.5	44.6	66.9	78.1	100.4	122.7	167.3	200.8	223.1	278.8	323.4	401.5	501.8
	475	31.7	42.2	63.2	73.8	95.1	116.1	158.2	189.9	211.1	263.9	306.1	379.9	474.8
	500	28.2	37.6	56.5	65.9	84.7	103.4	140.9	169.1	188.0	235.0	272.6	338.4	423.0
	538	25.2	33.5	50.0	58.4	75.2	92.0	125.5	150.5	167.2	208.9	242.3	300.7	375.8
	550	25.0	33.3	49.8	58.1	74.8	91.5	124.9	149.8	166.5	208.0	241.2	299.4	374.2
	575	24.0	32.0	47.9	55.9	71.8	87.8	119.7	143.6	159.6	199.5	231.4	287.3	359.1
	600	19.8	26.4	39.6	46.2	59.4	72.6	99.0	118.8	132.1	165.1	191.5	237.7	297.1
	625	13.9	18.5	27.7	32.3	41.6	50.8	69.3	83.2	92.4	115.5	134.0	166.3	207.9
	650	10.3	13.7	20.6	24.0	30.9	37.8	51.5	61.8	68.7	85.8	99.5	123.6	154.5
675	8.0	10.6	15.9	18.6	23.9	29.2	39.8	47.8	53.1	66.3	76.9	95.5	119.4	
700	5.6	7.5	11.2	13.1	16.8	20.6	28.1	33.7	37.5	46.8	54.3	67.4	84.2	
725	4.0	5.3	8.0	9.3	11.9	14.6	19.9	23.9	26.5	33.1	38.4	47.7	59.6	
750	3.1	4.1	6.2	7.2	9.3	11.4	15.5	18.6	20.7	25.8	29.9	37.1	46.4	
775	2.5	3.3	4.9	5.7	7.4	9.0	12.3	14.7	16.4	20.4	23.7	29.4	36.8	
800	2.0	2.7	4.0	4.7	6.1	7.4	10.1	12.1	13.5	16.9	19.6	24.3	30.4	
816	1.9	2.5	3.8	4.4	5.7	7.0	9.5	11.4	12.7	15.8	18.3	22.7	28.4	
A 351 Gr. CF8C GROUP 2.11 SPECIAL CLASS (1) (2)	38	51.7	68.9	103.4	120.6	155.1	189.6	258.6	310.3	344.8	430.9	499.9	620.5	775.7
	50	51.2	68.3	102.4	119.5	153.6	187.7	256.0	307.2	341.4	426.7	495.0	614.5	768.1
	100	48.9	65.2	97.9	114.2	146.8	179.4	244.7	293.6	326.3	407.8	473.1	587.3	734.1
	150	45.4	60.5	90.8	105.9	136.1	166.4	226.9	272.3	302.6	378.2	438.7	544.6	680.7
	200	43.1	57.4	86.1	100.5	129.2	157.9	215.3	258.4	287.1	358.8	416.2	516.7	645.8
	250	41.6	55.5	83.3	97.2	124.9	152.7	208.2	249.8	277.6	347.0	402.5	499.6	624.5
	300	40.2	53.6	80.3	93.7	120.5	147.3	200.9	241.1	267.9	334.8	388.4	482.1	602.6
	325	39.5	52.6	78.9	92.1	118.4	144.7	197.3	236.8	263.1	328.8	381.4	473.5	591.8
	350	38.8	51.7	77.6	90.5	116.4	142.3	194.0	232.8	258.7	323.3	375.0	465.5	581.9
	375	38.2	50.9	76.4	89.1	114.5	140.0	190.9	229.1	254.5	318.1	369.0	458.1	572.7
	400	37.8	50.4	75.7	88.3	113.5	138.7	189.2	227.1	252.3	315.4	365.9	454.2	567.7
	425	37.5	50.0	75.0	87.5	112.5	137.5	187.6	225.1	250.1	312.6	362.6	450.2	562.7
	450	37.3	49.8	74.7	87.1	112.0	136.9	186.7	224.0	248.9	311.1	360.9	448.0	560.0
	475	37.3	49.7	74.6	87.0	111.9	136.8	186.5	223.8	248.7	310.9	360.6	447.7	559.6
	500	35.6	47.6	71.5	83.4	107.1	130.9	178.6	214.3	238.1	297.5	345.1	428.3	535.4
	538	29.0	38.6	57.9	67.6	86.9	106.3	145.1	174.1	193.4	241.7	280.4	348.1	435.1
	550	29.0	38.6	57.9	67.6	86.9	106.3	145.1	174.1	193.4	241.7	280.4	348.1	435.1
	575	28.6	38.1	57.1	66.6	85.7	104.8	143.0	171.6	190.7	238.3	276.4	343.1	428.8
	600	24.8	33.0	49.5	57.8	74.3	90.8	123.8	148.6	165.1	206.4	239.4	297.2	371.4
	625	17.3	23.1	34.6	40.4	52.0	63.5	86.6	103.9	115.5	144.3	167.4	207.8	259.8
	650	12.9	17.2	25.7	30.0	38.6	47.2	64.4	77.3	85.9	107.3	124.5	154.5	193.1
675	9.9	13.2	19.9	23.2	29.8	36.4	49.7	59.7	66.3	82.9	96.2	119.4	149.2	
700	8.2	10.9	16.4	19.1	24.5	30.0	40.9	49.1	54.6	68.2	79.1	98.2	122.7	
725	5.9	7.9	11.8	13.8	17.7	21.6	29.5	35.4	39.4	49.2	57.1	70.8	88.5	
750	4.1	5.5	8.2	9.5	12.2	14.9	20.4	24.5	27.2	34.0	39.4	49.0	61.2	
775	3.1	4.1	6.2	7.2	9.3	11.4	15.5	19.5	22.2	28.8	32.3	38.5	46.4	
800	2.7	3.6	5.3	6.2	8.0	9.8	13.3	16.0	17.8	22.2	25.8	32.0	40.0	
816	2.4	3.2	4.7	5.5	7.1	8.7	11.8	14.2	15.8	19.7	22.9	28.4	35.5	

IMPORTANT: The above ratings are only for reference. Refer to ASME B16.34 for pressure/temperature ratings.

1. Permissible but not recommended for prolonged use at temperatures above approx. 427°C.

2. Shaded ratings may require special trim and packing. Consult your Flowsolve sales representative for applications in these ranges.

*Pressure temperature ratings are from ASME B16.34 "Valves, Flanged, Threaded and Welding Ends." Consult your Flowsolve sales representative for pressure temperature ratings of materials not included in this catalog.

1. Stop and Check Valve Applications Guide

1.1 Stop Valve Applications

Foreword

Edward stop valves are used primarily as isolation valves in medium and high pressure piping systems. They are offered in a broad range of sizes, pressure ratings, and types, and they are used in an immense array of diverse applications. Only a few are listed for illustration:

- Normally open valves in main steam lines; used only for equipment isolation, e.g. during maintenance.
- Normally open valves to provide for emergency shutoff due to failure of downstream piping or other equipment; closed periodically for verification of operability.
- Normally open valves that are throttled to varying degrees during start-up or shutdown of plants or systems.
- Frequently cycled valves that are opened and closed for control of batch processes or for start-up and shutdown of equipment (e.g., equipment that is on-stream daily but shut-down at night).
- Normally closed valves; used only for filling or draining systems during outages.

Stop valves are sometimes referred to as “on-off valves.” They should not normally be considered as “control valves,” but they are suitable for moderate or infrequent flow-control functions. Valves that must open and close under high differential pressure and flow conditions (such as “blowdown” service) inherently function as flow-control devices while they are stroking.

Considering the diversity of stop valve applications, it is not surprising that there is no universal valve type that is best for all services. Users’ experience with specific applications is a valuable basis for selecting the best valves.

The goal of this guide is to supplement users’ experience with information based on decades of Flowserve Edward Valves’ laboratory tests and field experience.

Introduction

While many other types of valves (ball, plug, butterfly) are used as stop valves where

service conditions permit, emphasis in this guide is on selection and application of Edward valves with forged- and cast-steel bodies and bonnets. Comparisons are presented with other similar valves where appropriate.

Edward stop valves are typically of metal-seated construction and, where necessary, use gaskets and stem seals designed for severe high-pressure, high-temperature service. While special designs with “soft seats” and O-ring seals are supplied for unique specific applications, the standard products are designed to stand up to tough service conditions with minimum requirements for maintenance or parts replacement.

Edward stop valves fall into two basic categories – **globe valves** and **gate valves**. The following sections of this guide will address the principal features of each type and the design variations within the types.

Globe valves are offered in stop, stop-check, and check versions. Stop-check valves can also be used for isolation in unidirectional flow applications. These valves are discussed in the Check Valves Applications section (1.2).

The FLOW PERFORMANCE section of this catalog provides equations and coefficients for the calculation of pressure drop across any of these valves. This information can be used to evaluate the effects of different valve sizes and types of system energy efficiency.

1.1.1 Stop Valve Types and Typical Uses

Brief notes on the advantages, disadvantages, applications and limitations of the various types of Edward stop valves are presented in the Stop Valve Applications Chart (section 1.1.4). Some additional highlights of the features of these valves and some comparisons with similar valves are presented in the following paragraphs.

Globe Valves

A globe valve employs a poppet or disk that opens and closes by moving linearly along the seat axis. There are many types of globe valve bodies, seats and methods of guiding the disk to and from the seat.

- **Bodies** – Edward stop, stop-check and check type globe valves are offered with three basic body styles:

Conventional or 90°-bonnet globe valves are usually the most compact, and the stem and yoke position allow easy handwheel or actuator access and convenience for maintenance. Relatively short stem travel allows fast actuation. Multiple direction changes in the flow stream result in higher pressure drop than with other types, but streamlined flow passages in Flowserve Edward valves generally yield lower pressure drop than competitive valves of this type.

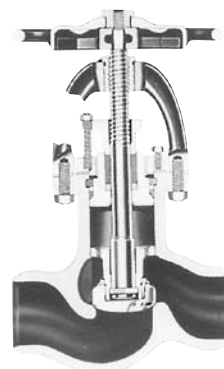

Angle valves are otherwise similar to conventional globe valves, but the less tortuous flow path yields lower pressure drop. Angle valves are particularly economical in piping layouts where use of this configuration eliminates an elbow and associated flanged or welded joints.

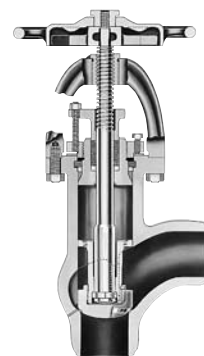

Inclined bonnet or “Y type” valves, such as Univalves® and Flite-Flow® valves, yield lower pressure drop than other styles, because they permit a more nearly straight-through flow path. Typically, they require a longer stem travel. In large sizes, this body shape is heavier and requires a greater end-to-end length than conventional globe valves.



• **Seats** – Industrial globe valves are available from various manufacturers with a broad variety of seat designs — flat or tapered, and integral or inserted (threaded or welded).

All Edward globe valves employ tapered seats with “area contact” under load to seal over minor imperfections. Many similar valves use “line-contact” seats that seal with less load when new but degrade rapidly if damaged at the seating line.

Except for hydraulic stop valves, all Edward globe valves employ integral (hardfaced) body seats to permit compact design and assure that there can be no leakage “behind” the seat.

• **Disk Guiding** – Globe valve disks may be guided by either the stem or the body. When opened or closed under very high differential pressure, side load due to flow pushes a stem-guided disk eccentric to the seat and makes it difficult to obtain a seal. Under extreme conditions, the stem may bend.

All Edward globe valves employ body guided disks which are held closely concentric with the body seat. Guiding is provided at both the top and bottom of the disk to form a fully body-guided disk piston. The bottom guide ring on the disk, a Flowserve Edward Valves innovation, minimizes flow behind the disk and minimizes the side load. These features make Edward globe valves well suited to “blowdown” applications in which there is a high differential pressure across the valve when it is partially open.

Since globe valves are not symmetrical with respect to flow, consideration must be given to the direction of flow and differential pressure. It should be noted that the direction of flow when open and differential pressure when closed may not be the same in all applications (e.g., a block valve on a feed line may involve flow into a system when open but may need to prevent leakage out of the

system when closed). Users should consider both factors when deciding on the installation direction for a globe valve.

In most globe valve applications, pressure is under the seat when the valve is closed, and the flow is from under to over the seat (termed “flow to open” or “underseat flow”). In installations where the downstream pressure is zero or very low, this arrangement minimizes packing leakage problems. However, handwheel or actuator effort to close the valve is high, because the stem must supply enough load to both overcome the differential pressure load across the seat area and ensure sufficient sealing load on the metal seat-contact surfaces. Since this flow direction is the most common for globe valves, the flow coefficients given in the Flow Performance section of this catalog are for underseat flow.

Globe valves can also be used with overseat flow and pressure (“flow to close”), but such applications require careful consideration. In systems with dirty line fluids, this arrangement could lead to trapping foreign material in locations where it would interfere with opening. With overseat pressure, the effort to close the valve is low, because closure and sealing are pressure-assisted. However, the effort to open the valve at high differential pressure is high, because the stem must overcome the pressure force to lift the disk (in small valves, the stem diameters approaching the seat diameter, this may not be a problem, because the pressure helps to lift the stem). Also, since the flow coefficients given in this catalog are for underseat flow, pressure-drop predictions may not be as accurate (pressure drop may be up to 10% higher with overseat flow).

While not designed as control valves and not recommended for continuous modulation, Edward globe valves are often used successfully for manual or automatic control during limited periods of system operation (start-up, shutdown, etc.). Some manual valves are also used for continuous throttling or “trimming.” Inclined-bonnet valves, (e.g., Univalves® and Flite-Flow® valves) have an approximately linear flow characteristic (C_v versus % open).

The Flow Performance section of this catalog covers only flow coefficients for fully open valves, but consult Flowserve concerning applications involving flow control. It should be understood that severe throttling at high pressure drops involves high energy dissipation, and serious problems (e.g., noise, vibration, cavitation, erosion) can develop if not carefully considered when a system is designed.



Gate Valves

A gate valve employs a closure member (or assembly) that opens and closes by moving perpendicular to the flow stream to engage two seats in the body. There are two basically different types of gate valves – parallel-side and wedge gate – in common use in pressure-piping systems, but there are many variations in design within each type.

As compared to globe valves, all gate valves offer straight-through flow paths which tend to produce less pressure drop than typical globe valves of the same nominal size. A Venturi gate valve with a smaller port than a Regular gate valve may offer a lower first cost as well as a size and weight saving if a minimized pressure drop is not required.

The Flow Performance section of this catalog gives comparable flow coefficients for Edward Equiwedge® gate valves and all Edward globe stop valves. Evaluation of many valve applications has shown that inclined-bonnet globe valves are often competitive with gate valves when all factors are considered.

The stem in a gate valve does not have to overcome the full differential pressure load across the valve seat area to open or close the valve. Instead, it just has to overcome the friction force due to that load. Consequently, for operation at similar differential pressures, a gate valve generally requires less effort for actuation than a globe valve and can employ a smaller actuator when powered operation is required. However, a gate valve requires considerably greater stem travel than a conventional globe or angle valve (slightly greater than an inclined-bonnet globe valve), so a somewhat longer time may be required for action.

The two body seats – the common feature in all ordinary gate valves – can be both an advantage and a disadvantage. Most gate valves are primarily “downstream-sealing,” because the closure member is pressure-energized in that direction. However, the upstream seating surfaces may help by limiting leakage if the

downstream seat is damaged. Simultaneous sealing at both seats can be hazardous if the center cavity of a closed valve is filled or partially filled with liquid and then subjected to an increase in temperature, causing a corresponding increase in pressure. In moderate cases, this may cause “pressure binding” which can impede or prevent valve opening; in extreme cases, it may cause pressure-boundary failure (e.g., the bonnet could blow off).

Note: ASME/ANSI B16.34-2004 (paragraph 2.3.3) places the responsibility of the purchaser to assure that the pressure in the valve will not exceed that allowed by the standard. Special operating procedures, such as partially opening a valve during warm-up, may be considered. Special internal design features or external bypass arrangements are required in many applications. Consult Flowserve regarding Edward Equiwedge® gate valve applications that may be subject to possible center-cavity over-pressurization.

Some highlights of the various types of gate valves, including the Edward Equiwedge, are discussed below:

• **Parallel-Slide Gate Valves**

Flowserve Edward Valves does not offer parallel-slide valves. In these valves, the two seats in the body are in parallel planes, and an assembly including two gates with parallel seating faces moves into or out of engagement with the body seats. The gates are urged into contact with the opposing seats in the closed position by either a spring (or a set of springs) or an internal wedge mechanism.

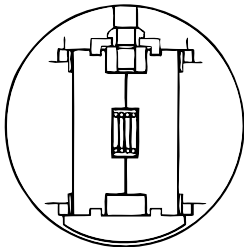

Parallel Slide Gate

Since the two gates are relatively independent, the downstream gate is free to align with the downstream seat, and new valves usually seal well so long as the differential pressure across the valve is sufficient to provide adequate seating load. Leakage may be a problem with these valves at low differential pressures (e.g. when filling a system or during low-pressure start-up operation).

In typical parallel-slide valves, there is continuous sliding contact between the sealing surfaces of the gates and body seats throughout the full stem stroke. Wearing or scoring is possible, particularly when operating with high differential pressures, and this

may cause seat sealing to be degraded. This shearing action may be helpful in cleaning loose debris from the seats, however.

• **Wedge Gate Valves**

A wedge gate valve uses one of the oldest engineering principles to provide mechanical advantage to convert stem load to seat-sealing load. This is particularly important in low-pressure applications where differential pressure alone may not provide sufficient loading on the downstream seat.

Early wedge gate valves for low pressure employed solid wedges, and these are still used in many small high-pressure gate valves. However, as industrial valve requirements moved toward larger sizes and higher pressures and temperatures, a solid wedge designed to provide sufficient strength became too rigid to accommodate the flexibility of the valve body. The seat planes deflect significantly in large, high-pressure valve bodies due to thermal effects and the loads from connecting piping, and a rigid wedge may either leak or bind in the closed position.

Many gate valves have been designed with “flexible” one-piece wedges that have overcome these problems to some degree, but the two halves of the wedge are not truly independent and free to align with the two opposing body seats. It is particularly difficult to provide torsional flexibility in the wedge to accommodate twist in the valve body.

Consequently, the Edward Equiwedge valve was designed with two independent, flexible wedge halves that permit relative rotation and can tilt to accommodate changes in the body-seat angles. The thickness of the wedges was minimized, while maintaining acceptable stresses, to allow deflection to accommodate out-of-flatness in the seat plane. In prototype tests, acceptable sealing was maintained with seats intentionally misaligned 1° in angle and up to 2° in rotation.

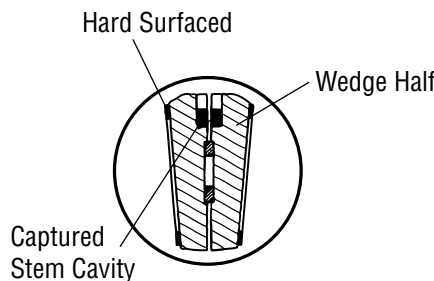

Double Wedge Design

The result is a valve that has high-pressure sealing performance comparable to that of a parallel-slide valve but that can also seal exceptionally well at low differential pressures. The independent, flexible wedge halves in Edward Equiwedge gate valves also have commendable resistance to sticking or binding in the closed position. In prototype tests, the valve always opened with a torque less than the design closing torque when exposed to extreme pipe-bending moments and severe thermal transients (heat-up and cool-down).

All wedge gate valves have body guides that must support the wedges when they are not in the fully closed position. The seating surfaces of the wedges and seats are in sliding contact only through a small portion of the opening and closing travel, thus minimizing wear that may degrade seat sealing. Outside that range, the side loads are transferred from the seats to the body guides. Wear or scoring of the body guides does not affect sealing.

In Edward Equiwedge gate valves, the body guides are vertical machined grooves at each side of the valve body which engage tongues on each side of the wedge halves. Precision machining allows transfer of side load from the seats to the body guides within 3% to 5% of valve travel. Testing has proven that this guiding system is rugged and supports the gate assembly effectively, even in “blowdown” services where high differential pressure loads act across the gates when the valve is partially open.

Gate valves of any type are usually not recommended for throttling or modulating flow-control service. The seating surfaces of the gates are subject to impingement when partially open, and some gate valves reportedly exhibit instability (internal vibration) when throttled. Nevertheless, high-velocity flow tests of a prototype Edward Equiwedge gate valve produced no flow-induced vibration, and there are cases where these valves have been used successfully for limited flow-control functions. Consult Flowserve concerning any proposed throttling or control applications.

1.1.2 Throttling Characteristics of Edward Stop Valves

As noted in the previous section, Edward stop valves are not normally recommended for continuous modulation, and Edward Valves should be consulted concerning applications involving flow control. This

section is intended only to provide general guidelines on flow-control characteristics of typical Edward stop valves. These guidelines may be used for preliminary studies relating to applications involving throttling, but they should not be considered as a substitute for a complete evaluation of the acceptability of a valve for a critical application.

Figure A

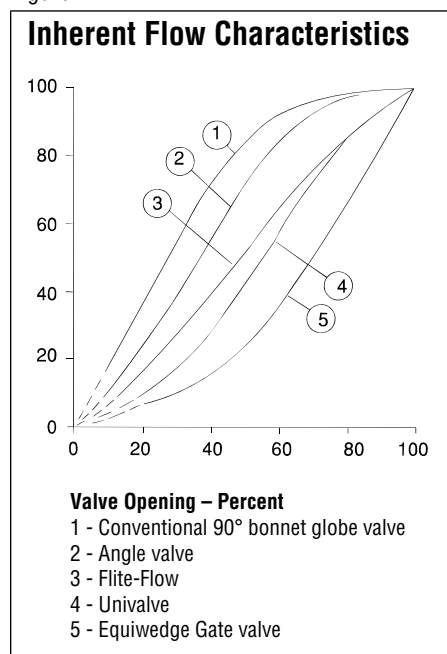

Figure A provides typical **inherent flow-characteristic** curves (percent of full-open flow coefficient versus percent opening) of the most common types of Edward stop valves. It should be understood that these curves are approximate, because there are variations due to size and pressure class that cannot be represented accurately by a single curve for each valve type. Nevertheless, these typical curves can provide some guidance relating to control capabilities of the various valve types.

Note the following subtle differences between the curves in Figure A:

- The conventional 90°-bonnet globe valve provides a relatively steep slope at small openings approaching a “quick-opening” characteristic. While the body-guided disk in Edward globe valves moderates this effect, it makes the flow coefficient very sensitive to small changes in stem position, so it may prove difficult to control low flow rates.
- The angle valve has a characteristic similar to that of a globe valve, but it is slightly

closer to linear due to its normally higher full-open flow coefficient. An angle valve has about the same control characteristics as a globe valve of the same size at small openings.

- The cast-steel Flite-Flow® Y-type valve provides a characteristic that is nearly linear over most of its stem-travel range. For control of flow over a broad range, the high flow efficiency of this type of valve may permit use of a smaller valve size for a given allowable pressure drop. The smaller size, combined with the linear characteristic, can give improved control of low flow rates when the valve is throttled.
- The forged-steel Y-type Univalve® provides even better control at very small openings because of its “double throttling” characteristic as the lower disk-guide ring opens the machined port in the body. Other forged-steel valves have this characteristic to some degree.
- The Equiwedge gate valve has an excellent inherent flow characteristic (“concave upward”), approaching that of an **equal-percentage** control valve. However, this is somewhat misleading. When installed in pipe of the same nominal size as the valve, the pressure drop of a gate valve is so low at large openings (e.g., over 70%) that piping flow resistance usually overshadows that of the valve. The gate valve would provide little control over flow in that range.

While not normally recommended for throttling for the reasons cited in the previous section, the gate valve flow-characteristic curve is attractive from a standpoint of controlling low flow rates without excessive sensitivity. Use of a gate valve for throttling may be considered for some applications.

1.1.3 Stop Valve Actuators and Accessories

Most Edward stop and stop-check valves illustrated in this catalog are shown with handwheels, and the majority of valves are furnished for applications where manual actuation is acceptable. Most larger and higher-pressure globe valves are furnished with standard Impactor handles or handwheels, which provide up to twelve times the stem force of an ordinary handwheel, to provide for adequate seating thrust. Impactogear assemblies on the largest globe valves permit operation using an air wrench. These Flowserve Edward Valves innovations permit practical manual operation of many valves

that would otherwise require gearing or power actuators.

Manual Gear Actuators

When specified, many Edward valves can be supplied with manual actuators with gear reduction in lieu of a handwheel. Such actuators reduce the required rim-pull effort and often permit operation by one person in cases where several people would be required to seat the valve with a handwheel. While manual gear actuators slow down operation, they are often an attractive option for valves that are not operated frequently. Operating pressure and differential pressure should be specified.

Note: Users sometimes specify that valves be operable at maximum differential pressure with very low rim-pull forces. This may require selection of gearing that may cause two problems: (1) literally thousands of handwheel turns for full-stroke valve operation and/or (2) capability to damage the valve easily with rim-pull forces that are readily applied by many operating personnel. Manual gear actuators with high ratios provide relatively little “feel” to the operator, and it is difficult to tell when a valve is fully open or closed. Good judgment should be exercised in specifying practical rim-pull force requirements.

Power Actuators

Where valves are inaccessible for manual operation or where relatively fast opening or closing is required, most Edward valves can be furnished with power actuators. The most commonly used actuators are electric actuators with torque- and position-control features. Users frequently have individual preferences on actuator brand names and type, so Edward valves can be furnished with Flowserve actuators or other brand actuators to satisfy customer requirements.

Flowserve establishes actuator sizes and switch setting based on specific valve-application requirements, using a computer program that matches the valve and actuator operating characteristics to the service-pressure conditions. Flowserve can help make this selection since we best know the requirements of our valve. However, we must also know the requirements of your application. As a minimum, requests for quotation should specify:

- Operating pressures – under-and over-seat and differential
- Maximum valve operating temperature
- Ambient conditions – temperature, humidity, radiation
- Motor power supply – AC voltage, frequency, and phase or DC voltage (including variance)

- NEMA rating
- Closing/opening time – if important. If not specified, standard nominal stem speed will be 4 inches/minute (100 mm/min) for globe valves and 12 inches/min (305 mm/min) for gate valves.
- Valve-stem plane – vertical (stem up or down) or horizontal
- Special accessories – position indicator, etc.

Any other special requirements should be clearly specified. If there are non-standard manual-override requirements, see the note above relative to rim-pull forces for manual gear actuators.

1.1.4 By-Passes and Drains

When specified, larger Edward cast-steel valves are furnished with valved by-passes and drains in accordance with ASME-ANSI B16.34 and MSS SP-45. Cast-steel stop valves employ forged-steel Edward globe stop valves, and cast-steel stop-check valves use forged steel Edward stop-check valves as by-pass valves. Sizes and by-pass valve figure numbers are as shown on page 96.

Drain valves for all main valves are the same as the by-pass valves listed for stop valves. When drains are specified without valves, the standard drain for class 300 and 600 valves is a NPT tapped hole in the valve body, fitted with a pipe plug. For class 900 and higher-pres-

sure valves, the standard drain is a pipe nipple, six inches (152 mm) long, socket-welded to the valve body.

Drain sizes are the same as by-passes. By-pass valves are particularly useful when opened before the main valve to permit controlled warming of the valve and downstream line in services involving steam or other hot fluids. By-passes also can be used to partially or fully balance the differential pressure across the main valve before opening where the downstream line or system is of limited volume. This facilitates opening of a gate valve or a glove valve with overseat pressure.

Large-volume systems may require larger by-passes for balancing in a reasonable time. If this is the case, a special by-pass size should be specified by the purchaser. It should be noted that actuated Edward Equiwedge gate valves do not require by-passes to permit opening if the full differential pressure is specified for actuator sizing. See page 96 for tables of standard sizes and pressure classes for most applications.

General schematic of stored energy gas-hydraulic actuator.

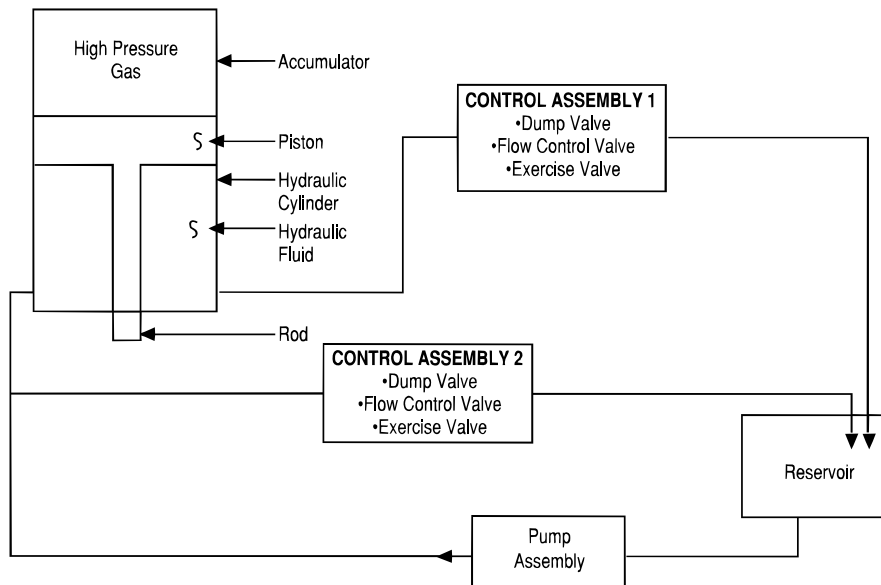

1.1.5 Stop Valve Application Chart

Type	Advantages	Disadvantages	Applications	Limitations
Globe 90° Bonnet	<ul style="list-style-type: none"> • Compact • Easy access to handwheel or actuator • Fast response 	<ul style="list-style-type: none"> • High pressure drop • High torque • Heavy in large sizes 	<ul style="list-style-type: none"> • Class 300-2500 steam and water • Other gasses and liquids • Usable for throttling 	<ul style="list-style-type: none"> • Not for stem-down installations • Sizes ¼ through 24
Angle	<ul style="list-style-type: none"> • Same as globe • Replaces an elbow • Lower pressure drop than globe 	<ul style="list-style-type: none"> • High torque • Heavy in large sizes 	<ul style="list-style-type: none"> • Same as globe 	<ul style="list-style-type: none"> • Same as globe
Globe Inclined Bonnet	<ul style="list-style-type: none"> • Lower pressure drop than globe or angle • May permit smaller size than globe 	<ul style="list-style-type: none"> • Same as angle • Longest end-to-end length • Handwheel or actuator on an angle • Long stem travel slows response 	<ul style="list-style-type: none"> • Class 600-4500 through size 4 • Class 300-2500 through size 24 • Otherwise, same as globe 	<ul style="list-style-type: none"> • Same as globe
Equiwedge® Gate	<ul style="list-style-type: none"> • Lowest pressure drop • Lowest torque • May permit smallest size 	<ul style="list-style-type: none"> • Not recommended for throttling • Long stem travel slows response with manual actuation 	<ul style="list-style-type: none"> • Class 600-2500 steam and water • Other gasses and liquids • Main steam isolation 	<ul style="list-style-type: none"> • Possibility of pressure binding • Sizes 2½ through 32

1.2 Check Valve Applications Guide

Foreword

Check valves are used in fluid circuits in applications similar to those in which diodes are used in electrical circuits. Reduced to simplest terms, the duty of most check valves is to allow flow in one direction and to prevent flow in the reverse direction. The ideal check would have zero resistance to flow in the normal flow direction and infinite resistance to flow (leakage) in the reverse direction. Of course, the ideal check valve should also be perfectly reliable and should require no maintenance.

There are many different types of check valves, and most do their duty well, giving long, trouble-free service. However, in the real world, no single type of check valve achieves the ideal performance characteristics users sometimes expect. In a very few cases, mismatching of check valves to the needs of fluid circuits has produced serious problems (noise, vibration, severe pressure surges and check-element failures with attendant gross leakage and consequential damage to other equipment). While it is not necessary for every application to be ideal, knowledge of the characteristics of each type of check valve should help system designers and valve users to select the best type and size intelligently. This knowledge should also help in assuring that serious problems are avoided.

Most check valves seem deceptively simple, with only one moving part — a poppet or flapper that appears capable of allowing flow in only one direction. However, this single mechanical part cannot be expected to take the place of a sophisticated control system that senses flow (direction, quantity, rate of change) and provides output to (1) open the valve fully when flow is in one direction and yet (2) close the valve to prevent flow and leakage in the reverse direction. Each type of check valve has features that enable it to perform one or more of its duties well, but each type also has weaknesses. The relative importance of these strengths and weaknesses is highly dependent on the requirements of individual applications.

The goal of this guide is to provide application engineers and users with practical advice on check valve selection and sizing, location in piping systems, preventive maintenance and repairs. Emphasis will be on Flowserve Edward Valves products, but

comparisons will be provided in some cases with other types of check valves.

This guide is based on extensive testing of Edward check valves in sizes from NPS ½ through 18 as well as a reasonable sampling of other types. Since complete performance testing of every valve type, size and pressure class is not practical, predictions of the performance of some valves are based on mathematical models. However, the models are based on substantial test data and are believed to be reasonably accurate or conservative. The laboratory test files cover over forty years. Perhaps even more important, the files include feedback from substantial field experience — in fossil and nuclear-fueled power plants, refineries, chemical plants, oil fields and in countless other applications. It is hoped that this test and field experience will help others avoid problems and pitfalls in the application and use of check valves.

Introduction

This guide has been prepared to aid fluid-system designers in sizing and selecting check valves for industrial and power-piping systems. Guidance is also provided on valve orientation (inclination from horizontal, etc.) and on location of check valves with respect to other flow disturbances. In addition, this guide should aid users in planning preventive maintenance programs, performing maintenance and repairs when necessary, and in evaluating and correcting problems.

Emphasis in this guide is on selection and application of forged- and cast-steel Edward Valves products, but comparisons with other types of check valves are given where this can be done based on valid information.

The Flow Performance section of this catalog provides equations and coefficients for the calculation of pressure drop and the flow required to assure full valve opening. In addition, that section provides most of the necessary supplemental data required for routine calculations, such as water and steam density.

This guide also provides caution notes relative to system-related problems to be avoided (such as piping vibration, flow instability, waterhammer). Some of these guidelines are qualitative and could involve further analysis. However, attention to these notes should help to avoid problems.

Finally, this guide addresses check valve maintenance. History indicates that preventive maintenance of check valves is often

neglected, and this can lead to serious valve failures which may damage other equipment. The guidelines provided on periodic inspection and preventive maintenance should pay off in terms of reduced overall plant maintenance and repair costs.

1.2.1 Check Valve Types and Typical Uses

While other types are sometimes encountered in power hydraulics and other specialized applications, four basic types of check valves are commonly used in industrial and power piping applications.

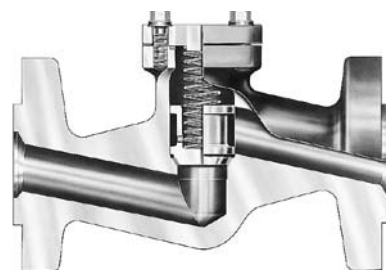

1-Lift Check Valves

The closure element is a poppet or disk that is lifted open by flow and which seats, usually on a mating conical surface in the valve body, under no-flow conditions.

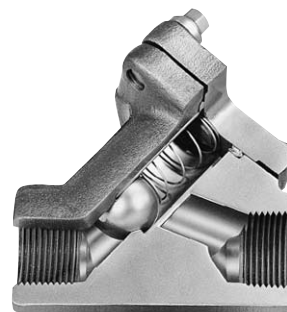

2-Ball Check Valves

A lift check valve in which the closure element is a ball.

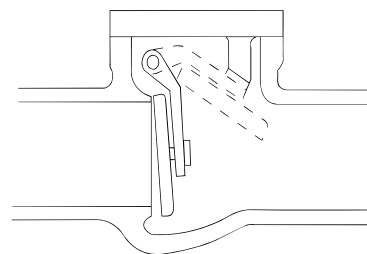

3-Swing Check Valves

The closure element is a pivoted flapper which is swung open by flow and which seats, generally against a mating flat surface in the valve body, under no-flow conditions.

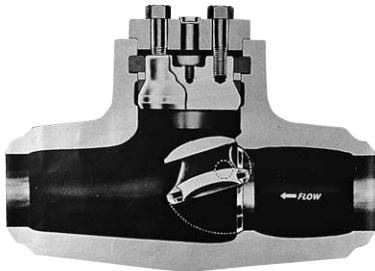

4-Tilting-Disk Check Valve

The closure element is a pivoted disk or flapper, somewhat like that in a swing check valve but with a pivot axis close to the center of the flow stream. It is swung open by flow and seats against a mating conical surface in the valve body under no-flow conditions.

There are many variations among these four basic types of check valves. For example, springs may be included to assist closure and counteract gravitational forces, and accessories may be provided for exercising or position indication. All Edward lift check valves employ body-guided disks with a piston-like extension to provide good guidance and resistance to wear. Accordingly, they are referred to in this guide as piston-lift check valves. In addition, Flowserve manufactures Edward stop-check valves which are piston-lift check valves that allow positive closure for isolation, just like globe stop valves.

Illustrations of the Edward valve types manufactured by Flowserve are provided in this catalog, and brief notes on advantages, disadvantages, applications, and limitations are provided in the Check Valve Applications Chart (section 1.2.2). Some further highlights of the features of these valves are provided in the following paragraphs.

Edward Piston-Lift Check Valves

In both small forged-steel and large cast-steel Edward lines, three distinctly different valve body styles appear in the illustrations – inclined-bonnet globe valve style, angle valve style, and 90°-bonnet globe valve style.

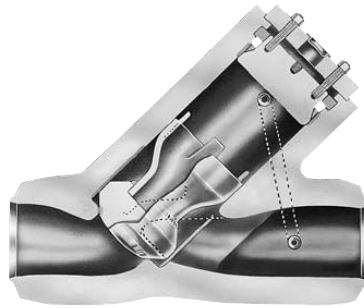

With respect to check valve function, these valves are all similar, with only slightly different orientation limits as discussed in the Valve-Installation Guidelines section (1.3). The main difference between these systems is in flow performance:

- Inclined-bonnet piston-lift check valves produce low pressure drop due to flow when fully open. They have flow coefficients comparable to those of tilting-disk check valves and only slightly lower than provided by many swing check valves.
- In most cases, angle piston-lift check valves have lower flow coefficients and thus produce more pressure drop than inclined-bonnet valves, but they are superior to 90°-bonnet valves. Where a piping system requires a bend and a valve, use of an angle piston-lift check valve eliminates the cost and pressure drop of an elbow and the cost of associated piping welds or flanged connections.
- 90°-bonnet piston-lift check valves have the lowest flow coefficients and produce pressure drops comparable to 90°-bonnet globe valves. They are sometimes preferred in systems where pressure drop is not critical or where space requirements dictate a minimum size and easy access to a handwheel or actuator (on a stop-check valve).

Piston-lift check valves are generally the most practical type for small sizes, and they generally provide the best seat tightness. Small forged-steel piston-lift check valves normally include a disk-return spring, but may be ordered without springs. The Flow Performance section of this catalog and section 1.3 below address such valves, both with and without springs. Cast-steel piston-lift check valves have equalizer tubes which connect the volume above the piston with a relatively low-pressure region near the valve outlet. This feature allows a much larger valve opening (and higher flow coefficient)

than would be possible otherwise, and it allows the valve to open fully at a relatively low flow.

The body-guided feature of Edward piston-lift check valves is an advantage in most services, because it assures good alignment of the disk with the valve seat and minimizes lateral vibration and wear. However, this feature may lead to sticking problems due to foreign-material entrapment in unusually dirty systems. Another inherent characteristic is that large piston-lift check valves may not respond rapidly to flow reversals and may cause water-hammer problems in systems where the flow reverses quickly [see the Pressure Surge and Waterhammer section (1.4.2)]. Since smaller valves display inherently faster response, historic files have shown no water-hammer problems with small forged-steel check valves.

Edward Stop-Check Valves

Stop-check valves offer the same tight sealing performance as a globe stop valve and at the same time give piston-lift check valve protection in the event of backflow. A stop-check valve is nearly identical to a stop valve, but the valve stem is not connected to the disk. When the stem is in the “open” position, the disk is free to open and close in response to flow, just as in a piston-lift check valve. When serving as a check valve, stop-check valves display the same advantages and disadvantages as discussed above for piston-lift check valves. Small forged-steel stop-check valves, except the Univalve® stop-check valves, employ a disk-return spring, and cast-steel stop-check valves have equalizer tubes that function in the same manner as those on comparable piston-lift check valves.



The stem in the stop-check valve may be driven either by a handwheel or an actuator, and it may be used either to (1) prevent flow in the normal direction when necessary for isolation or (2) supplement line pressure to

enhance seat tightness in applications with pressure from the downstream side. Some users automate stop-check valves to give extra system protection against reverse flow and leakage. For example, an actuator may be signaled to close the valve when a pump is shut off; the disk closes quickly by normal check valve action, and the stem follows to seat the valve firmly a short time later.

Edward Ball Check Valves

Ball check valves are offered only in small forged-steel configurations (size 2 and smaller) with inclined-bonnet bodies and ball-return springs. These valves are recommended over piston check valves, for service with viscous fluids or where there is scale or sediment in the system. The bolted-bonnet versions offer flow performance that is generally similar to that of equivalent piston-lift check valves, and they are the preferred ball check valves for most industrial and power-piping applications.

The threaded-bonnet hydraulic ball check valves are used primarily in very high pressure, low-flow applications with viscous fluids. They have lower flow coefficients that have proven acceptable for those services. These valves sometimes exhibit chattering tendencies when handling water, so they are not recommended for low-viscosity fluids.

A unique feature of the ball check valve is that the ball closure element is free to rotate during operation, allowing the ball and seat to wear relatively evenly. This feature, combined with the standard return spring, helps to promote positive seating even with heavy, viscous fluids.

Edward Tilting-Disk Check Valves

Tilting-disk check valves are particularly well-suited to applications where rapid response and freedom from sticking are essential. Fully open valves of this type also exhibit low pressure drop. They have flow coefficients comparable to those of Edward inclined-bonnet piston-lift (Flite-Flow^{www}) check valves and only slightly lower than provided by many swing check valves.

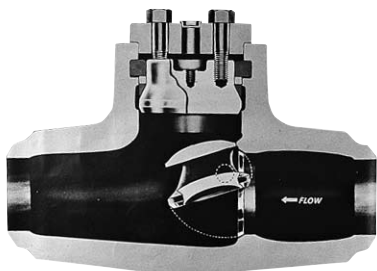

Tilting-disk check valves provide rapid response, because the center of mass of the disk is close to the pivot axis. Just as in a pendulum, this characteristic promotes rapid motion of the disk toward its natural (closed) position whenever the force holding it open is removed. This response can be valuable in applications where relatively rapid flow reversals may occur, such as in pump-discharge service where multiple pumps discharge into a common manifold. In such cases, the flow may reverse quickly, and the rapid response of the tilting-disk check valve minimizes the magnitude of the reverse velocity and the resulting waterhammer pressure surge. This characteristic also minimizes impact stresses on the disk and body seats. However, an extremely rapid flow reversal, as might be produced by an upstream pipe rupture, could cause a problem. See the Pressure Surge and Water Hammer section (1.4.2) for further discussion.

Size-6 and larger tilting-disk check valves have totally enclosed torsion springs in their hinge pins to help initiate the closing motion, but the disk is counterweighted to fully close without the springs. With the free pivoting action of the disk, this type of valve is highly immune to sticking due to debris in the system.

Tilting-disk check valves are superficially similar to swing check valves in that both operate on a pivoting-disk principle. However, the pivot axis in a swing check valve is much farther from the disk's center of mass, and this increases the "pendulum period" and hence the time required for closure in services with flow reversal. In addition, the one-piece disk in the tilting-disk check valve avoids the necessity of internal fasteners and locking devices, which are required to secure disks to pivot arms in most swing check valves. However, like swing check valves, tilting-disk check valves have hinge pins and bearings that are subject to wear due to disk flutter if the valve is not fully open and/or there are flow disturbances or instabilities. Such wear may produce eccentricity of the disk and seat when the valve closes, leading to a degradation of seat tightness (particularly at low differential pressures). Applications involving severely unstable flow or prolonged service without preventive maintenance can lead to failures in which the disk separates completely from the hinge pins and will not close. Other sections of this guide address the flow conditions which may lead to problems as well as maintenance recommendations.

Edward Elbow-Down Check and Stop-Check Valves

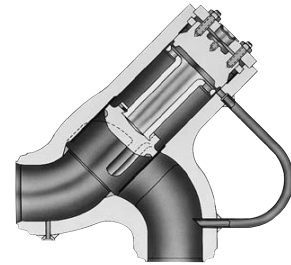

Elbow-down piston-lift check and stop-check valves are similar to Flite-Flow valves except that the valve outlet is in the form of an elbow to direct the flow downward. These valves were designed specifically for applications in controlled-circulation power plants, and they have special clearances and other design features. Because of these special features, the sizing and pressure-drop calculation methods given in the Flow Performance section of this catalog do not apply. However, special elbow-down valves can be furnished with conventional check valve design features for applications where this valve-body geometry is desirable.



Edward Combinations of Check and Stop-Check Valves

As noted in the Foreword to this section (1.2), no single type of check valve achieves ideal performance characteristics. The advantages and disadvantages noted in the Check Valve Applications Chart (section 1.2.2) and other information in this catalog should assist in selection of the best valve size and type for any specific application. However, the selection of any single valve may require undesirable compromises.

Some system designers and users specify two check valves in series for critical applications, and this does give some insurance

1.2.2 Check Valve Applications Chart

Type	Advantages	Disadvantages	Applications	Limitations
Piston Lift Check	<ul style="list-style-type: none"> • Very low pressure drop in inclined bonnet valves • Relatively low pressure drop in angle valves • Larger valves incorporate an external equalizer • Minimum chatter due to flow disturbances • Good seat tightness • Forged steel valves with spring can be mounted in any orientation 	<ul style="list-style-type: none"> • Relatively high pressure drop in 90° bonnet valves • Subject to “sticking” in very dirty systems 	<ul style="list-style-type: none"> • Class 300-4500 service • High temperature steam and water • Refining, petrochemical, chemical, etc. • Oilfield production • Can be used in series with Tilting Disk Check to provide maximum line protection (advantages of both types). 	<ul style="list-style-type: none"> • Sizes ¼ through 24 • For orientation limits see valve installation guidelines • For flow limits see Flow Performance section of this catalog
Ball Check	<ul style="list-style-type: none"> • Wear on body seat and check element evenly distributed • Long service life • Forged steel valves with spring can be mounted in any orientation • Available with either integral or threaded seat for hydraulic valve • Low cost 	<ul style="list-style-type: none"> • High pressure drop • Available only in small sizes 	<ul style="list-style-type: none"> • Class 600 and Series 1500 service • Water, steam, refining, petro-chemical, chemical, etc. • Service where scale and sediment exist • Viscous fluids 	<ul style="list-style-type: none"> • Sizes ¼ through 2 • For orientation limits see valve installation guidelines • Not recommended for gas service at low flow rates • For flow limits see Flow Performance section of this catalog
Tilting Disk Check	<ul style="list-style-type: none"> • Very low pressure drop • Straight through body design • Very fast closing • Minimizes disk slamming and waterhammer pressure surges • Will not “stick” in dirty systems 	<ul style="list-style-type: none"> • Not recommended for service with rapidly fluctuating flow • Seat tightness may deteriorate at low differential pressure 	<ul style="list-style-type: none"> • Class 600-4500 service • High temperature steam and water • Refining, petrochemical, chemical, etc. • Oilfield production • Can be used in series with Piston Lift check or Stop-Check to provide maximum line protection (advantages of both types) 	<ul style="list-style-type: none"> • Sizes 2½ through 24 • For orientation limits see valve installation guidelines • For flow limits see Flow Performance section of this catalog
Stop Check	<ul style="list-style-type: none"> • See Piston Lift Check above • Can be used for Stop valve service • Stem can be lowered onto disk to prevent chatter at low flow • Stem force can overcome “sticking” 	<ul style="list-style-type: none"> • See Piston Lift Check valve above 	<ul style="list-style-type: none"> • See Piston Lift Check above 	<ul style="list-style-type: none"> • See Piston Lift Check above

that at least one valve will close even if the other valve fails. However, if two identical valves are used, a system characteristic that is troublesome to one valve could produce problems with both. In such cases, use of two valves does not assure double safety or double life. Sometimes it is worth considering the selection of two different types of check valve, each with advantages to offset disadvantages of the other.

One specific check valve combination has been used in applications of Flowserve Edward valves to provide advantages that no single valve can offer. A tilting-disk check valve in series with a piston-lift check valve offers minimum waterhammer and freedom from sticking (from the tilting-disk) and good seat tightness (from the piston-lift check). The disadvantage is added pressure drop and cost, but the pressure-drop penalty is minor if the Flite-Flow inclined-bonnet piston-lift check valve is used. Even the cost penalty may be offset if a stop-check valve is used, because it may be able to take the place of a stop valve that would be required otherwise for isolation.

1.3 Check and Stop-Check Valve Installation Guidelines

Unlike stop valves, which can be installed in any position with little or no effect on performance, most check and stop-check valves have limitations as to their installed orientation. Although the normal installation is in a horizontal or vertical line (depending on valve type), check and stop-check valves can be installed in other orientations. It should be noted, however, that valves installed in other than the normal positions may exhibit a degradation of performance, service life and resistance to sticking, depending on the flow conditions and cleanliness of the line fluid. For maximum reliability, it is recommended that piston-lift check valves and stop-check valves be installed with flow axis horizontal (vertical inlet and horizontal outlet for angle valves) with the bonnet above the valve in a vertical plane. Following are maximum out-of-position orientations that may be used for less critical applications and which should never be exceeded.

- All Edward forged-steel check and stop-check valves (except Univalve® stop-check valves) are normally furnished with spring-loaded disks and may be installed in any position. The spring-loaded disk enables positive closure regardless of valve position.

Figure 1
45° Inclined Bonnet Piston Lift Check Valves
Maximum Check Valve Orientation Limits

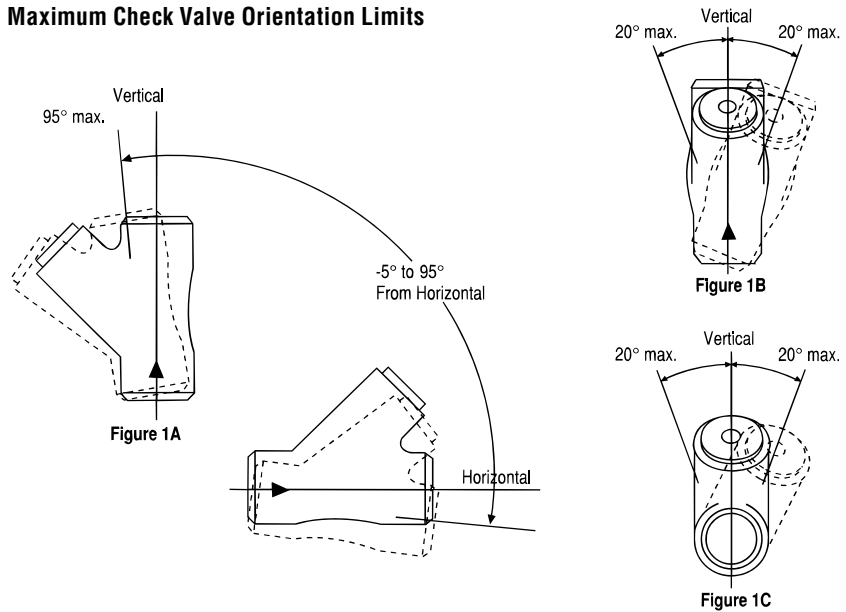
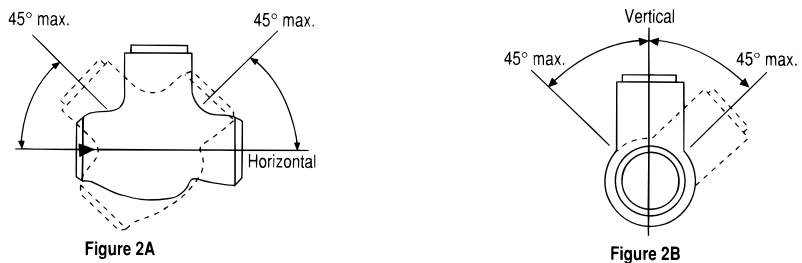

Figure 2
90° Bonnet Piston Lift Check Valves
Maximum Valve Orientation Limits



Note: For piston lift check valves, any installation resulting in combined out of position orientation, such as a valve in an inclined line with a rollover angle as well, should limit the angle of the bonnet to the following:

- 45° from vertical for angle and 90° bonnet valves.
- 50° from vertical for inclined bonnet valves.

However, installed positions in which dirt or scale can accumulate in the valve neck should be avoided. An example of this would be an inclined-bonnet valve installed in a vertical pipeline with downward flow. If forged-steel valves are ordered without springs, the limitations below should be observed.

- Edward cast-steel Flite-Flow®, forged-steel Univalve, and inclined-bonnet check and stop-check valves without springs, when installed in vertical or near vertical lines,

should be oriented such that the fluid flow is upward and the angle of incline of the line is not more than 5° past the vertical in the direction of the bonnet. When installed in horizontal or near horizontal lines, the valve bonnet should be up and the angle of incline of the line should be not more than 5° below the horizontal. See Figure 1A. Also, the roll angle of the valve bonnet should not be more than 20° from side to side for either vertical or horizontal installations. See Figures

Figure 3
Angle Piston Lift Check Valves
Orientation Limits

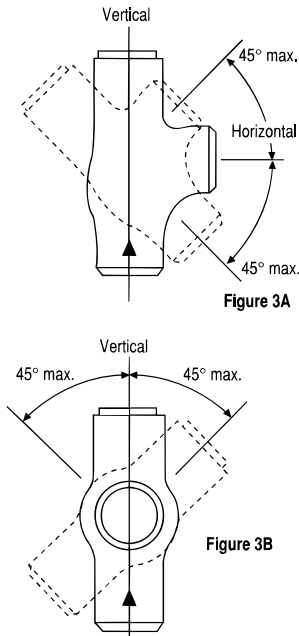
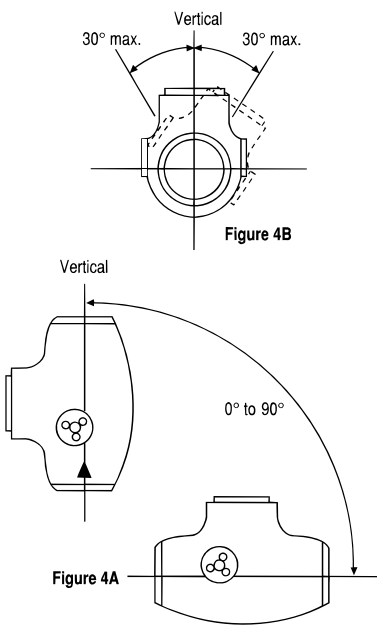

Figure 4
Tilting Disk Check Valves
Orientation Limits



1B and 1C. Consult your Flowsolve Edward Valves representative concerning installation limits of bolted-bonnet forged-steel check valves without springs.

- Edward cast-steel and forge-steel 90°-bonnet check and stop-check valves without springs should be installed with the bonnet up, and the angle of incline of the line should not be more than 45° from the horizontal. Also, the roll angle of the valve bonnet should not be more than 45° from side to side. See Figures 2A and 2B.

- Edward cast-steel and forged-steel angle check and stop-check valves without springs should be oriented such that the incoming flow is upward, and the angle of incline of the line should not be more than 45° in either direction. See Figure 3A and 3B.

- Edward tilting-disk check valves may be installed in horizontal lines and vertical lines and at any incline angle in between. When the incline angle is not horizontal, flow should always be up. The roll angle of the valve should not be more than 30° from side to side. See Figures 4A and 4B. Also, when installed in other than vertical lines, the bonnet should always be oriented up.

Figure 5
Pipe fittings near valves may produce instability because of velocity profile distortion

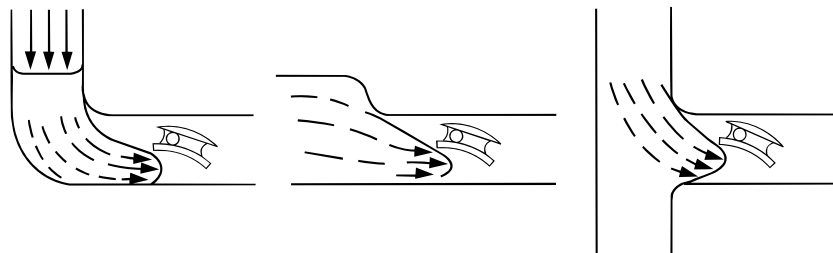
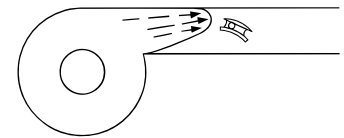
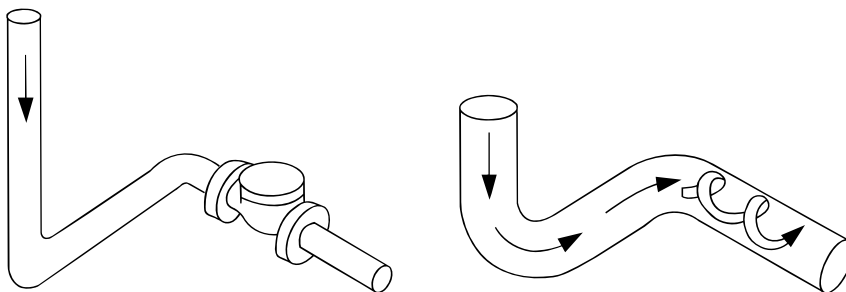

Figure 6
Non-uniform velocity profile at blower or pump discharge can affect stability.



In each case described above, the limitations given for line inclination and bonnet roll angle should not be combined.

Figure 7
Elbows in two places cause swirl which can promote instability.



It should be understood that the information given in the section of this catalog entitled Flow Performance is based on traditional horizontal orientations. For other orientations, the pressure drop and flow required for full lift may be affected. In addition, seat tightness, particularly at low differential pressures, may be adversely affected.

Orientation restrictions may also exist for power-actuated stop-check valves. Most linear valve actuators are designed to be mounted upright and nearly vertical, although they can usually be modified for mounting in any position. When selecting a stop-check valve and power actuator, be sure to specify the mounting position desired if not vertical and upright.

1.3.1 Adjacent Flow Disturbances

Check valves, like other valve types, are generally tested for performance and flow capacity in long, straight-pipe runs. Flow coefficients obtained from these tests are then used to predict the flow rate or pressure drop that will be experienced in actual applications. The ideal installation of a check valve in a plant would be in a long run of straight pipe so that performance would correspond to the test conditions. Since space limitations involved with many installations preclude such ideal straight-pipe runs, the effects of adjacent pipe fittings, control valves, pumps and other flow disturbances must be considered.

Previously published data have indicated that flow disturbances, particularly upstream disturbances, may significantly affect check valve performance. It has been reported that valve flow capacity may be significantly reduced as compared to that measured in straight-pipe tests, and there have been strong suggestions that such disturbances aggravate check valve flutter and vibration. Since these conditions could degrade valve performance and contribute to rapid wear and premature valve failure, they are important factors in evaluating check valve applications. Figure 5 illustrates how upstream pipe fittings may alter the flow profile entering a check valve, crowding it to one side or the other. A similar distortion occurs in a valve located near the discharge of a centrifugal pump or blower, as shown in Figure 6. Elbows in two planes cause a flow stream to swirl, which might produce unusual effects on a check valve installed as shown in Figure 7.

Since there was no known way to predict the effects of flow disturbances on check valves by mathematical models, Flowserve conducted extensive testing of size 2, 4, 8 and 10 check valves in straight-pipe runs and in piping with upstream flow disturbances. Figures 8 and 9 illustrate typical flow-test setups.

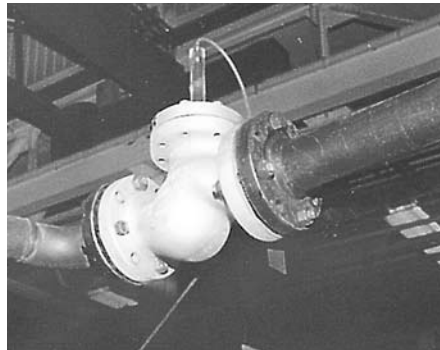

Figure 8
Size 4 Class 600 90° bonnet piston lift check valve with two upstream elbows (out of plane). This arrangement produces swirl as shown in Figure 7.

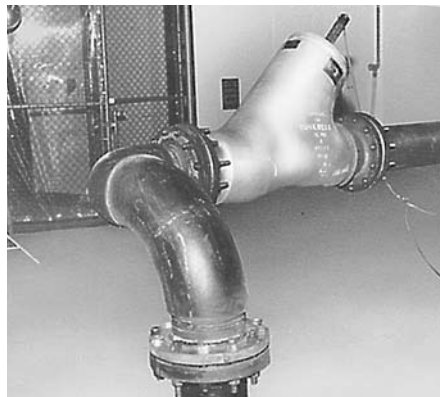

Figure 9
Size 10 Class 1500 Flite-Flow® inclined bonnet piston lift check valve with two upstream elbows. Test loop capacity permitted tests with line velocity over 20 ft/s (6 m/s).

In most tests, room temperature water was the flow medium, but limited straight-pipe testing was performed with air. The valves tested included Edward piston-lift check (inclined-bonnet, angle and 90°-bonnet), tilting-disk check valves and a size-4 swing check valve manufactured by another company. The tests were designed to evaluate the effects of flow disturbances on (1) valve stability, particularly when partially open; (2) flow rate required to open the valve fully; and (3) the flow coefficient (C_v) of the valve. The flow disturbances evaluated included single and double (out of plane) 90° elbows in various orientations immediately upstream of the check valves. In addition, the effects of a throttled, upstream control valve were simulated with an offset-disk butterfly valve (at various throttle positions) mounted im-

mediately upstream, as well as at five and eleven pipe diameters upstream, of the check valves.

With few exceptions, tests with ten or more diameters of straight pipe upstream of check valves produced little cause for concern. In water flow tests, visual position indicators usually showed only minor disk “wobble” or very small open-close flutter (e.g. less than 1° total rotation of a tilting disk), even at very low flows and small valve openings. The only conditions that produced severe instability were those involving air flow at very low pressures (below 50 psi or 3.4 bar) and valve openings less than 20%. Such conditions produced significant cyclic motion, with disks bouncing on and off the body seats. In view of the many uncertainties in applying laboratory test results to service conditions, it is considered prudent to avoid operating conditions which produce check valve openings of less than 25%, even in ideal straight-pipe applications.

Highlights of the results of the Flowserve tests with flow disturbances are given in Table A on page 131. The test program clearly showed that upstream flow disturbances do affect check valve performance, but the effect is not always predictable. The magnitude of the effect can vary, depending on the type and even the size of the valve. In some cases, even the direction of the effect (improvement or degradation) varies from valve to valve. Nevertheless, some general observations on the results of these tests are:

- Single and double upstream elbows produced less severe effects on check valve performance than had been expected, and some valves displayed no discernible effects. For example, Edward angle piston-lift check valves exhibited the same stability, lift and flow coefficients (C_v) with upstream elbows as with straight pipe. In tests of other types of valves, upstream elbows produced both beneficial and adverse effect to various degrees.

- In each case where a check valve was tested with a throttled butterfly valve immediately upstream, there were significant effects on performance. The effects included increased disk flutter and reduced valve opening at a given flow, as compared to straight-pipe performance. In some cases, full check valve opening could not be achieved at any flow within the capabilities of the test loop.

Even where full opening was obtained, some valves continued to flutter on and off their

stops. These effects were worst when the butterfly valve was most severely throttled (smallest opening and highest pressure drop). In the worst cases, the butterfly valve exhibited audible cavitation, but it is not clear whether the adverse effects resulted from simple flow distortion or the two-phase flow stream from the cavitating butterfly valve.

In similar tests with the butterfly valve moved 5 diameters upstream of the check valve (but with similar throttling), the adverse performance effects were decreased significantly but not eliminated. When the butterfly valve was moved 11 diameters upstream of the check valve, normal check valve performance was restored.

The results of these tests were enlightening, but they must be combined with observations based on field experience. For example, while upstream elbows produced less severe effects than expected, there were still adverse effects on some valves. It is difficult to extrapolate a laboratory test to years of service in a plant installation, but Flowserve service files include an interesting and relevant incident. Two size-12 tilting-disk check valves in one plant had hinge-pin failures over a time period of several months

after 25 years of service. While this incident might best be cited as a case for more inspection and preventive maintenance, the details of the installation were investigated. It was determined that the flow rates were in a range that should have assured full disk opening, but the valves were installed close to upstream elbows.

Users of this catalog may wish to refer to EPRI Report No. NP 5479 (see the Sources for Additional Information section of this catalog) for further data on the performance of swing check valves in tests similar to those conducted by Flowserve. The size-4 swing check valve used in the Flowserve test program had a stop positioned to restrict the disk-opening angle to about 38°. This valve opened fully at a relatively low flow and exhibited reasonably stable performance. The tests sponsored by EPRI showed that other swing check valves (with less restrictive stops) exhibited larger amplitudes of flutter than were observed in comparable Flowserve tests.

The following guidelines are based on Flowserve tests and field experience, combined with other published information:

- If possible, check valves near flow disturbances should be sized to be fully open, preferably by a good margin, even at the lowest sustained flow rate anticipated for each application. The Flow Performance section of this catalog provides methods for sizing Edward check valves for new installations or for evaluating existing applications. When flow-induced forces load a valve closure element firmly against a stop, it is less likely to flutter and suffer from rapid wear.

Full opening does not guarantee freedom from problems if the margin is not sufficient to provide a firm load against the stop. Equalizers on Edward cast-steel piston-lift check and stop-check valves enhance this margin and provide good stop loading, but flow disturbances may cause other valve disks to bounce on and off their stops. This “tapping” phenomenon may cause faster wear than flutter about a partially open position. For this reason, the minimum sustained flow rate through a tilting-disk check valve near flow disturbances should be about 20% greater than the flow rate required to just achieve full opening.

If it is not possible to ensure full opening of a check valve at minimum flow conditions,

Table A – Effects of Upstream Flow Disturbances on Check Valve Performance

Valve Size and Type	Single Elbow at Valve Inlet ¹	Double Elbows (Out of Plane) at Valve Inlet	Throttled Butterfly Valve		
			At Valve Inlet	5 Diam. Upstream	11 Diam. Upstream
Size 2, Inclined-Bonnet, Piston-Lift Check	Higher Lift for Same Flow; Disk Flutter at Lower Lifts ²	Higher Lift for Same Flow	NA	NA	NA
Size 4, Angle, Piston-Lift Check	No Effect	No Effect	NA	NA	NA
Size 4, 90°-Bonnet, Piston-Lift Check	Same, Lower or Higher Flow for Full Lift	No Effect	Disk Flutter and Chatter: Failure to Achieve Full Open	NA	NA
Size 4, Swing Check	Smaller Opening for Same Flow	Smaller Opening for Same Flow	Larger Opening for Same Flow; Disk Flutter	NA	NA
Size 8, Angle, Piston-Lift Check	No Effect	NA	NA	NA	NA
Size 8, 90°-Bonnet, Piston-Lift Check	Disk Flutter at Partial Lift	NA	NA	NA	NA
Size 10, Inclined-Bonnet, Piston-Lift Check	Same or Lower Lift for Same Flow; Slight Disk Wobble	No Effect	Failure to Achieve Full Open; Disk Flutter and Chatter	Failure to Achieve Full Open	No Effect
Size 10, Tilting-Disk Check	No Effect	Minor Flutter	Same, Lower or Higher Lift for Same Flow; Disk Flutter and Chatter	Minor Flutter	No Effect

1: Tests were conducted with single 90° elbows in the horizontal plane and in the vertical plane (with flow both from above and below).

2: One size-2 valve exhibited flutter at lower lifts; another was stable.

at least 25% opening should be ensured. Valves operating at partial opening for significant periods of time should be monitored regularly to determine if there is instability or wear.

- In view of uncertainties associated with long-term effects of flow disturbances, it is recommended that a minimum of 10 diameters of straight pipe be provided between the inlet of a check valve and any upstream flow disturbance (fittings, pumps, control valves, etc.), particularly if calculations indicate that the check valve will not be fully open for a substantial portion of the valve service life. There should be a minimum of 1 to 2 diameters of pipe between the check valve and the nearest downstream flow disturbance.

- In the specific case of upstream elbows, reasonably successful performance should be attainable with 5 diameters of straight pipe between an upstream elbow and a check valve if the valve will not be partially open for a significant portion of its service life. Tests described in EPRI Report No. NP 5479 indicate that elbows installed 5 diameters or more upstream had a negligible effect on swing check valves, and this is expected to be true for other check valve types. Even less straight pipe may be satisfactory, but such close spacing should be reserved for applications with very tight space constraints. More frequent inspection and preventive maintenance should be planned for valves in such installations.

- In the specific case of throttled upstream control valves, the minimum requirement of 10 upstream pipe diameters should be adhered to rigidly. Calculations indicating full valve opening based on straight-pipe tests cannot be trusted to prevent problems, because severe flow disturbances may prevent full opening. Even greater lengths of straight pipe should be considered if the control valve operates with very high pressure drop or significant cavitation.

- Users with existing check valve installations that do not meet these guidelines should plan more frequent inspection and preventive maintenance for such valves. If a check valve is installed close to an upstream control valve that operates with a high pressure drop, considerations should be given to a change in piping or valve arrangements.

1.3.2 Other Problem Sources

In addition to the fundamentals of check valve selection, sizing and installation, several other potential sources of check valve

problems should be considered in applications engineering or, if necessary, in solving problems with existing installations:

• Piping-System Vibration

In other sections of this guide, it has been noted that check valve damage or performance problems may result from flow-induced flutter or vibration of the closure element. Very similar damage may result from piping-system vibration. Such vibration may originate at pumps, cavitating control valves or other equipment. Check and stop-check valves are susceptible to vibration damage, because the check element is “free floating” when partially open, with only the forces due to fluid flow to balance the moving weight. Impact damage and internal wear may result if the valve body vibrates while internal parts attempt to remain stationary. This condition may be avoided by adequately supporting the piping system near the check valve or by damping vibration at its source. Of course, it is helpful to assure that the check element opens fully, because flow forces at the disk-stop help to inhibit relative motion.

• Debris in Line Fluid

Debris in the flow stream can cause damage and performance problems in check and stop-check valves. Debris entrapped between the disk and seat may prevent full closure and lead directly to seat leakage. If hard particles or chips are in the debris, they may damage the seating surfaces and contribute to seat leakage even after they are flushed away. Debris caught between the disk and the body bore of a piston-lift check valve can cause the disk to jam and prevent full opening or closing. To ensure best check valve performance and seat tightness, line fluids should be kept as clean as practical. As noted before, tilting-disk check valves are particularly resistant to sticking or jamming, but they are no more resistant to seat damage than other types.

• Unsteady (Pulsating) Flow

An unsteady flow rate can lead to rapid check valve damage, particularly if the minimum flow during a cycle is not sufficient to hold the valve fully open. The valve may be damaged just because it does what a check valve is designed to do – open and close in response to changes in flow. As an example, a check valve installed too close to the outlet of a positive displacement pump may attempt to respond to the discharge of each cylinder. If the mean flow during a cycle is low, the disk may bounce off the seat repeatedly in a chattering action. If the mean flow is higher,

the disk may bounce on and off the full-open stop. Such pulsating flows may be difficult to predict. For example, a steam leak past the seat of an upstream stop valve may produce a “percolating” action in a line filled with condensate and cause a check valve to cycle. Such problems may only be discovered by preventive maintenance inspections.

• Vapor Pockets in Liquid Piping Systems

Unusual phenomena are sometimes observed in piping systems containing hot water that partially vaporizes downstream of a closed check valve. Vapor pockets at high points may collapse suddenly when the check valve opens (due to the start-up of a pump, for example). This collapse may be remote from the check valve and have no effect on the check valve performance. However, if a vapor pocket exists in the upper part of a piston-lift check or stop-check valve body (above the disk), the collapse may generate unbalanced forces in the direction of disk opening. Since the vapor offers little fluid resistance, rapid acceleration of the disk toward the fully open position may occur. In extreme cases, the disk or bonnet stops may be damaged due to impact. Such thermodynamic quirks are difficult to anticipate when designing a piping system and are sometimes as difficult to diagnose if they occur in an existing installation. Changes in piping arrangements or operating procedures may be necessary if severe problems occur. It is possible that similar problems may occur during low-pressure start-up operations in unvented liquid-piping systems.

1.4 Check Valve Performance

1.4.1 Check Valve Seat Tightness

Edward check valves are factory-tested with water in accordance with MSS SP-61 (Manufacturers Standardization Society of the Valve and Fittings Industry, Inc.) at an overseat pressure of 1.1 times the pressure ratings of the valve. While check valves are allowed leakage rates up to 40 ml/hr per unit of nominal valve size by MSS SP-61, Flowserve allows no more than 5% of this leakage for cast-steel valves and no visible leakage for forged-steel valves. Tilting-disk and forged-steel check valves are then tested again at a reduced pressure with allowable leakage rates which are less than the MSS SP-61 requirements.

Closed check valve closure elements (disk, ball, flapper, etc.) are acted on by a combination of forces produced by gravity, springs

(where applicable) and reversed differential pressure. While gravity and spring forces help to position the closure element into the substantially closed position, metal-to-metal seating check valves typically rely on pressure forces to produce the seating loads necessary for good seat tightness.

Some metal-seated check valves do not produce good seat tightness at low differential pressures, particularly when the pressure increases from zero. A threshold level of differential pressure is required to produce uniform metal-to-metal contact and restrict leakage to a reasonable rate. An even higher level is required to ensure that a valve meets leakage-rate criteria like those in MSS SP-61. Unfortunately, these levels of differential pressure are difficult to predict; they vary with valve type, condition and orientation (and with cleanliness of line fluid).

Tests of new valves in horizontal lines show that cast-steel inclined-bonnet and 90°-bonnet piston-lift check and tilting-disk check valves seal off reasonably well at under 50 psi (3.4 bar) when differential pressure increases from zero. Small forged-steel ball and piston-lift check valves are less consistent, sometimes seating at less than 50 psi (3.4 bar) and sometimes requiring 250 psi (17 bar) or more. This “seating” action often occurs suddenly when the pressure forces shift the closure element into good metal-to-metal contact with the body seat, and leakage generally continues to decrease as the pressure is increased. Once seated, most valves seal well if pressure is reduced below the threshold required for initial seating, but the seat tightness with reducing pressure is also difficult to predict.

Some of the Edward check valves described in this catalog have been manufactured with “soft seats” to provide improved seat tightness at low differential pressures. This design feature includes an elastomeric or plastic sealing member on the valve closure element to supplement the basic metal-to-metal seating function. Since the design and material selection for these sealing members are very sensitive to pressure, temperature and compatibility with the line fluid, there are no standard, general-purpose, soft-seated valves. Consult Flowserve for further information about specific applications.

Foreign material in the flow medium is a major source of leakage problems in many valves. Because of the limited seating forces in check valves, dirt has a far greater effect on the tightness of these valves than other

types. Attention to cleanliness of the fluid is necessary where good check valve seat tightness is desired.

Incorrect sizing or misapplication of a check valve can also lead to leakage problems. Chattering of the closure element on its seat due to insufficient flow or pressure can cause damage to the seat or closure element and result in leakage.

In applications where check valve leakage is a problem, a stop-check valve may offer the solution. Stem load from a handwheel or actuator can provide the necessary seating force independent of pressure. Of course, the stem must be returned to the “open” position to allow flow in the normal direction. Consult Flowserve about applications that are usually sensitive to leakage.

A complete treatment of the subject of pressure surge and waterhammer is beyond the scope of this catalog, but some discussion is provided so that application engineers may appreciate the significance of the problem as it relates to check valves.

1.4.2 Pressure Surge and Waterhammer

One part of the problem is that the terminology or jargon is not consistently used. For example, “waterhammer” or “steam hammer” is sometimes used to describe the implosion which occurs when water enters a hot, low pressure region and causes a steam void to collapse. This has occurred in systems with a failed check valve, where the water came back from a large reverse flow through the check valve. However, the more common “waterhammer” problem associated with check valves occurs as a result of the check valve closing and suddenly terminating a significant reversed flow velocity. This problem is generally associated with valves handling water or other liquids. A similar pressure surge phenomenon may be encountered with steam or gas, but it is generally much less serious with a compressible flow medium.

Waterhammer is a pressure surge produced by the deceleration of a liquid column, and it involves pressure waves that travel at close to the velocity of sound through the fluid. It is commonly illustrated in texts by an example involving rapid closure of a valve in a long pipe. For such a case, it can be shown that instantaneous closure of a valve in a room-temperature water line will produce an increase in pressure of about 50 psi (3.4 bar) above the steady-state pressure for

every 1 ft/sec (0.30 m/sec) decrease in water velocity. Even if the valve does not close instantaneously, the same pressure increase would develop if the upstream pipe is long enough to prevent reflected pressure waves from reaching the valve before it closes. The waves of increasing pressure that are generated by the closing valve “reflect” from a constant-pressure reservoir or vessel, if present in the system, and return to the valve as inverted waves that decrease pressure. A solution to the “textbook problem” is to slow down the valve closure so that the reflected pressure waves attenuate the surge. However, this is not necessarily the best approach in the case of a check valve.

In a check valve, the fluid velocity is forward before the valve starts to close, but it reduces due to some system action (e.g., a pump is shut off). If the velocity reverses before the valve closes, a waterhammer surge will be produced by a conventional check valve that is nearly proportional to the magnitude of the maximum reversed velocity. Figure 10 provides curves illustrating flow transients associated with different types of systems and flow interruptions. The graphs illustrate velocity in the pipe, forward and reverse, versus time on arbitrary scales. The following discussions describe each of the curves:

- **Curve A** illustrates flow coast-down in a simple circulating loop, such as a cooling system, following switch-off of pump power. The momentum of the pump impeller and the fluid keeps the fluid going forward until it is decelerated and finally stopped by friction. There would be no need for a check valve to prevent reverse flow in this system, but one might be included to permit pump maintenance without draining other equipment. In normal operation of this system, the check valve could produce no waterhammer.

- **Curve B** illustrates an application with a pump feeding a high-pressure system with a fairly large volume. It might represent a boiler feed system of a pump feeding a high reservoir. In this case, assuming similar momentum in the pump and fluid, forward flow continues for a while after the pump is switched off, but the downstream pressure decelerates the flow more rapidly and then reverses its direction. Without a check valve, the reverse flow would increase and stabilize at some value, unless the downstream system pressure declined. In the illustration, the magnitude of the maximum reverse velocity is drawn less than the initial forward velocity, but it might be higher in some systems.

Figure 10 - Flow Reversal Transients

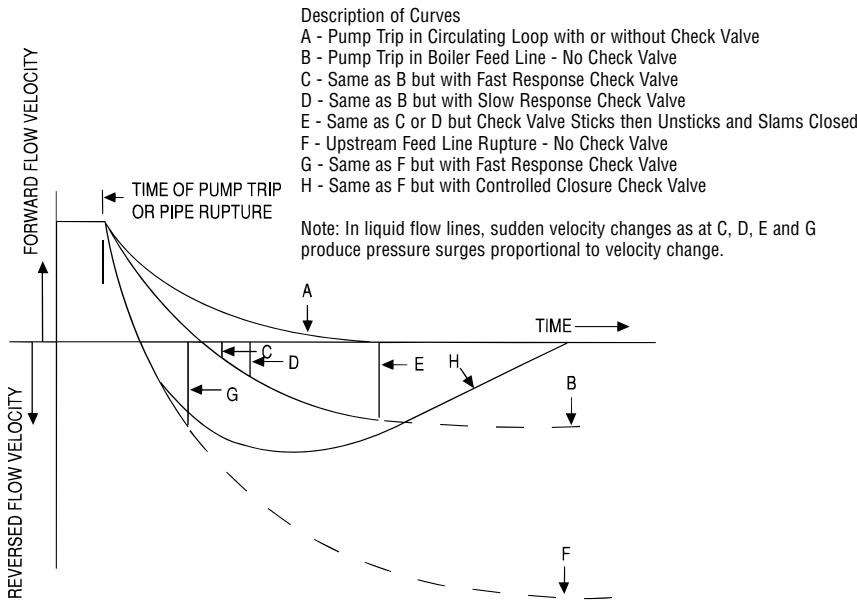

analyses and tests have shown that even the most rapid-responding conventional check valve could produce unacceptable waterhammer surges. This led to the development of the special controlled-closure check valve (CCCV—see Figure 11). Since high reverse velocities are inevitable, the CCCV solves the problem the way the “textbook problem” discussed above is solved—by closing slowly. The CCCV is a piston-lift check valve, but it has an internal dashpot which slows the closing speed of the valve. Closing speed depends on the rate at which water is squeezed out of the dashpot chamber, through flow paths that are sized for each application.

- **Curve H** illustrates the velocity variation in the pipe-rupture situation described for Curve F, but with a CCCV in the line. In this case, the maximum reverse velocity might even be higher than in Curve G, but it is decelerated back to zero slowly, allowing reflected reducing-pressure waves to minimize the resulting waterhammer surge. Figure 12 provides a comparison between a conventional check valve and a CCCV for a specific pipe-rupture situation. Note that the conventional check valve closes in 0.07 seconds as compared to 1.0 seconds for CCCV. As a result, the conventional check valve produced a surge of 3000 psi (207 bar) while the CCCV limits the surge to 600 psi (41 bar). These characteristics have been demonstrated in tests and can be duplicated in computer-based dynamic analysis simulations of specific valves and systems.

While the CCCV solves a special problem, even this sophisticated product does not fulfill the definition of an ideal check valve. By closing slowly, it allows significant reverse blow before it seats. This characteristic might be undesirable in common pump-discharge applications, because the reverse flow might have adverse effects on pumps or other equipment. Studies of systems designs sometimes show that fast-response check valves, such as the tilting-disk type, should be retained at pump discharge points where an upstream pipe rupture is unlikely, with CCCVs applied at locations where an upstream pipe rupture could cause serious consequences (e.g., in feedwater lines inside the containment vessel of a nuclear power plant).

In Curves C, D, E, and G of Figure 10, it may be noted that the final terminations of reverse velocity are shown as substantially vertical lines. This does not imply that the valve closes instantaneously. However, tests of

Figure 11 - Controlled Closure Check Valve (CCCV)

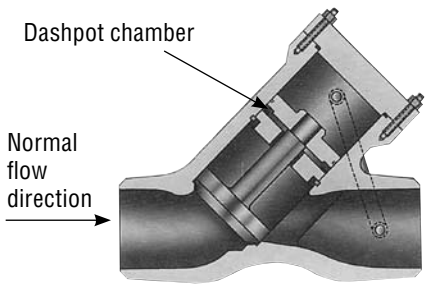

- **Curve C** illustrates what would happen in the system described for Curve B with a fast-response check valve (e.g., a tilting-disk type) installed. As discussed in the Foreword to this guide, an “ideal” check valve would allow no reverse flow and would close exactly at the time the velocity curve passes through zero; there would be no waterhammer. A “real” check valve starts closing while the flow is still forward, but it lags the velocity curve. With fast response, it closes before a high reverse velocity develops, thus minimizing the waterhammer surge.

- **Curve D** illustrates the same system with a check valve that responds just a bit slower. It shows that just a small increase in check valve lag may allow a large increase in re-

verse velocity (and a corresponding increase in waterhammer surge pressure).

- **Curve E** illustrates an accidental situation that might develop with a severely worn valve or a dirty system. If a check valve in the system described above should stick open, it might allow the reverse velocity to build up so as to approach that which would occur without a check valve. If the reverse flow forces should then overcome the forces that caused the sticking, the resulting valve stem could cause a damaging waterhammer surge.

- **Curve F** illustrates what might happen in the system described for Curve B if there were a major pipe rupture just upstream of the check valve. With free discharge through the open end, the flow would decelerate much more rapidly and, without a check valve, reach a much higher reverse velocity.

- **Curve G** shows the response of the system in Curve F if even a fast-response conventional check valve were to be used. With a flow deceleration this rapid, even a small lag may result in a very high reverse velocity to be arrested and a correspondingly high waterhammer surge.

Fortunately, it is not necessary to design every piping system with a check valve to cope with a pipe rupture. However, this requirement has emerged in some power-plant feedwater piping systems. Flowserve

Figure 12 - Example Comparison of Closure Time and Surge Pressure Conventional vs Controlled Closure Check Valves

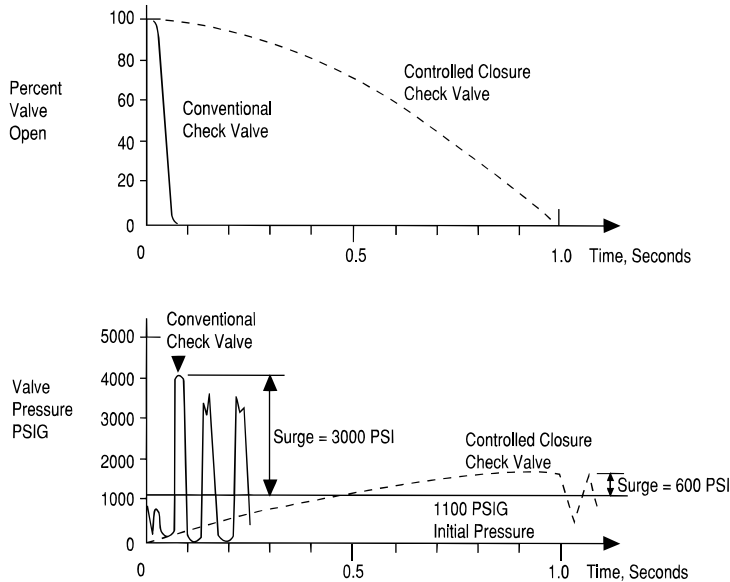
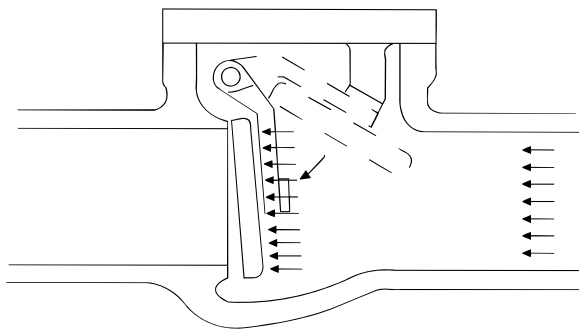

Figure 13 - Reverse Flow in Conventional Swing Check Valve - Just Before Closing



conventional check valves show that the reverse velocity in the pipe containing the valve does terminate almost instantaneously. This apparent contradiction may be understood by referring to Figure 13, which illustrates a check valve approaching the closed position with reverse flow (while the illustration depicts a swing check valve, the flow condition discussed here would be much the same with a poppet or disk in a conventional lift check or piston-lift check valve).

The key observation from Figure 13 is that a column of fluid follows the closure element at roughly the same velocity that the closure element has as it approaches its seating

surface in the valve body. While the valve may start to close while the flow velocity is still forward (see Figure 10), an undamped check valve has little effect on pipe flow during closure, and the disk velocity is about the same as the reverse flow velocity in the pipe at the instant just before closure. Since the disk is stopped substantially instantaneously when it makes metal-to-metal contact with the body seat, the reverse flow velocity in the pipe must also be arrested instantaneously. Because of this characteristic, the surge produced by the slam of a conventional check valve cannot be attenuated significantly by reflected reducing-pressure waves, and the

surge tends to be relatively insensitive to system pipe lengths.

In some check valve applications, problems have been observed due to a phenomenon that is related to waterhammer but not as widely recognized. When a high-pressure wave is produced on the downstream side of a check valve at closure, a reverse low-pressure wave is produced on the upstream side. If this low-pressure wave reduces the fluid pressure to below the saturation pressure of the fluid, a vapor pocket can form. This can be compared to a tensile failure of the flow stream, and it is sometimes referred to as column separation or column rupture. This vapor pocket is unstable and will collapse quickly, with an implosion that produces a high-pressure “spike.” It is possible for this pressure surge to exceed the one initially produced on the downstream of the check valve. Instrumented laboratory tests have shown that the upstream pressure spike sometimes causes the disk to reopen slightly and “bounce” off its seat once or twice. In very rare occasions, sometimes involving systems with multiple check valves, this characteristic has been known to amplify, leading to damaging pipe vibrations.

In summary, waterhammer can produce complex problems in check valve applications. Numerical solutions to these problems require sophisticated computer-based dynamic analyses of both the check valve and the fluid in the piping system. This catalog does not provide the methods for making such analyses; instead, the information in this section is intended to assist fluid-system designers in avoiding the problem.

Users who already have check valves in liquid flow lines that emit loud “slams” when they close should be aware that the noise is probably associated with pressure surges that could lead to fatigue problems in the valve, piping or other components. Where the existing check valve is a piston-lift check or stop-check valve, the solution could be to add a tilting-disk check valve in series with the existing check valve to gain the advantages of both valve types. Where the existing valve is a swing check valve, replacement by a tilting-disk check valve might be considered. See the section of this catalog entitled Check Valve Types and Typical Uses (1.2.1) for a discussion of the strengths and weaknesses of the various valve types.

1.4.3 Check Valve Accessories and Special Features

Edward Check valves can be provided with various accessories which are used to induce check-element motion (exercise) or indicate check-element position. Some of the features available are as follows:

- Visual disk-position indicator for tilting-disk check valve
- Electrical open/close position indicator for tilting-disk or cast-steel piston-lift check valve
- Manual or pneumatic actuator to partially open tilting-disk check valve under zero differential pressure
- CCCVs can be furnished with an injection port which allows the valve disk to be exercised by injecting water into the dashpot chamber when the valve is under a zero differential pressure.

1.4.4 Check/Stop-Check Valve Periodic Inspection and Preventive Maintenance

Periodic inspection and preventive maintenance of check and stop-check valves should be performed to ensure that the valves are operating properly. Bonnet-joint leakage and packing leakage on stop-check valves are easy to detect. Seat leakage of a check or

stop-check valve might be indicated by one of the following: a definite pressure loss on the high-pressure side of the valve; continued flow through an inspection drain on the low-pressure side; or, in hot water or steam lines, a downstream pipe that remains hot beyond the usual length of time after valve closure. Leakage of steam through a valve which is badly steam-cut has a whistling or sonorous sound. If the valve is only slightly steam-cut, however, leakage is identified by subdued gurgling or weak popping sounds. These sounds can often be heard through a stethoscope.

Excessive vibration, noise or humming coming from within a piston-lift check or stop-check valve indicates the possibility that the disk-piston assembly is wedged inside the body. Such sticking may be caused by uneven body-guide rib wear on the downstream side. Sticking rarely occurs with tilting-disk check valves.

“Tapping,” “thumping” or “rattling” noises detected from or near a check valve may indicate disk instability or cavitation. Instability could lead to rapid wear and possible valve failure. Audible cavitation is also detrimental. It may produce damage to the valve or the downstream piping. While the noise symptoms may be transmitted through the pipe from other equipment, prompt investigation is required if the check valve’s performance is critical to plant reliability.

No specific inspection/preventive maintenance schedule can be given to cover all check valves. It is suggested that small valves be sampled by size and type (there may be hundreds in a large installation). Schedules for audit of larger valves should consider the criticality of the valve service. It is wise to open some critical valves for internal inspection at intervals even if no suspicious noises are detected.

Where check valves are installed close to pumps, control valves, pipe fittings or other flow disturbances, they should have more frequent inspection [see the section of this catalog entitled Adjacent Flow Disturbances (1.3.1)]. In addition, attention should be given to valves in installations with significant pipe vibration.

Users of this guide may wish to consider non-intrusive check valve monitoring methods as a supplement to periodic visual inspection and measurement of check valve internals. Noise and vibration, acoustic emission, ultrasonic and radiographic methods have been studied and demonstrated. EPRI Report No. NP 5479 provides an evaluation of the state of the art, but users are advised to obtain the most current information available on these emerging technologies.

If problems are found through any of the inspections discussed above, refer to section J: Maintenance.

2. Flow Performance

2.1 Choose the Best Valve Size for Your Service Conditions

The most economical valve is the valve correctly sized for the service flow conditions. Too small a valve will have a high pressure drop and will incur expensive energy costs in service. Too large a valve wastes money at the time of purchase, and it may require excessive effort or an excessively large and expensive actuator for operation.

Piping-system designers sometimes optimize the size of valves and piping systems to minimize the sum of investment costs and the present value of pumping power costs. While this may not be practical for selection of every valve, it is a goal that should be kept in mind. This catalog provides information necessary to evaluate the various types and sizes of Edward valves for stop (isolation), stop-check and check valve applications.

In the case of stop-check and check valves, another consideration is that an oversized valve may not open completely. Obviously, if a valve is not fully open, the pressure drop will be increased. Also, if the disk operates too close to the seat, unsteady flow may cause flutter that may damage valve seats, disks or guides.

System designers should also address “turn-down” if service conditions involve a broad range of flow rates (e.g., high flow in normal operation but low flow during start-up and standby conditions). For these reasons,

selection of check valves requires extra steps and care in calculations.

This section includes equations for the calculation of pressure drop, required flow coefficient, flow rate or inlet flow velocity. Procedures are also provided to check and correct for cavitation and flow choking. The equations in this section assume that the fluid is a liquid, a gas or steam. Two-component flow (e.g. slurries, oil-gas mixtures) is not covered by the equations. Consult Flowsolve for assistance in evaluating such applications.

Tables in this section contain performance data for all Edward stop, stop-check and check valves. Flow coefficients and cavitation/choked-flow coefficients are given for all fully open Edward valves. In addition, for check and stop-check valves, the tables provide minimum pressure drop for full lift, crack-open pressure drop, and a novel “sizing parameter” that is helpful in selecting the proper valve size for each application.

Caution: Pressure drop, flow rate and check valve lift estimates provided by Edward calculation methods are “best estimate” values. Calculations are based on standard equations of the Instrument Society of America (ISA), flow rate and fluid data provided by the user, and valve flow coefficients provided by Flowsolve.

Flow rate and fluid data are often design or best-estimate values. Actual values may differ from original estimates. Flow and check valve lift coefficients are based on laboratory testing. Valves of each specific type are tested, and results are extended to sizes not tested using model theory. This approach

is fundamentally correct, but there is some uncertainty because of geometric variations between valves.

These uncertainties prevent a guarantee with respect to valve pressure drop, flow rate and lift performance, but we expect results of calculations using Flowsolve methods to be at least as accurate as comparable calculations involving flow and pressure drop of other piping system components.

2.1.1 Pressure Drop, Sizing and Flow Rate Calculations – Fully Open Valves – All Types

This section is divided into two parts. The Basic Calculations section (2.2) covers most applications where pressure drops are not excessive. This is generally the case in most Edward valve applications, and the simple equations in this section are usually sufficient for most problems.

When the pressure drop across a valve is large compared to the inlet pressure, refer to the Corrections Required with Large Pressure Drops section (2.3). Various fluid effects must be considered to avoid errors due to choked flow of steam or gas – or flashing or cavitation of liquids. While use of these more detailed calculations is not usually required, it is recommended that the simple checks in that section always be made to determine if correction of the results of the Basic Calculations is necessary. With experience, these checks can often be made at a glance.

Note: In preliminary calculations using the following equations, a piping geometry factor, $F_p = 1.0$, may be used, assuming that the valve size is the same as the nominal pipe size. However, if an application involves installing a valve in a larger-sized piping system (or piping with a lower pressure rating than the valve, which will have a larger inside diameter), determine F_p from the Pipe Reducer Coefficients section when final calculations are made.

2.2 Basic Calculations

The following equations apply to FULLY OPEN gate and globe valves of all types. They also apply to stop-check and check valves if the flow is sufficient to open the disk completely. The Check Valve Sizing section (2.4) must be used to determine if a check valve is fully open and to make corrections if it is not.

The following simple methods may be used to calculate pressure drop, required flow coefficient, flow rate or inlet flow velocity for fully open Edward valves in the majority of applications. Always check Basic Calculations against the $\Delta P/p_1$ criteria in Figure 14 to see if corrections are required. This check is automatically made when using the Proprietary Edward Valves Sizing Computer Program.

2.2.1 Pressure Drop

KNOWN:

Flow rate (w or q)

Fluid specific gravity (G) or

Density (ρ)

For water, steam or air, see Figures 21-23

FIND: Valve flow coefficient (C_v) from appropriate table

CALCULATE: Pressure drop (ΔP)

When flow rate and fluid properties are known, determine required coefficients for a specific valve and calculate the pressure drop from the appropriate equation (see Nomenclature table for definition of terms and symbols):

Equation 1a (U.S.)

$$\Delta P = G \left(\frac{q}{F_p C_v} \right)^2$$

Equation 1b (metric)

$$\Delta P = G \left(\frac{q}{0.865 F_p C_v} \right)^2$$

Equation 1c (U.S.)

$$\Delta P = \frac{1}{\rho} \left(\frac{W}{63.3 F_p C_v} \right)^2$$

Equation 1d (metric)

$$\Delta P = \frac{1}{\rho} \left(\frac{W}{27.3 F_p C_v} \right)^2$$

If the resulting pressure drop is higher than desired, try a larger valve or a different type with a higher C_v . If the pressure drop is lower than necessary for the application, a smaller and more economical valve may be tried.

2.2.2 Required Flow Coefficient

KNOWN:

Flow rate (w or q)

Allowable pressure drop (ΔP)

Fluid specific gravity (G) or density (ρ)

For water, steam or air, see Figures 21-23

CALCULATE: Minimum required valve flow coefficient (C_v)

When the flow, fluid properties and an allowable pressure drop are known, calculate the required valve flow coefficient from the appropriate equation:

Equation 2a (metric)

$$C_v = \frac{q}{F_p} \sqrt{\frac{G}{\Delta P}}$$

Equation 2b (metric)

$$C_v = \frac{q}{0.865 F_p} \sqrt{\frac{G}{\Delta P}}$$

Equation 2c (U.S.)

$$C_v = \frac{W}{63.3 F_p \sqrt{\Delta P \rho}}$$

Equation 2d (metric)

$$C_v = \frac{W}{27.3 F_p \sqrt{\Delta P \rho}}$$

Results of these calculations may be used to select a valve with a valve flow coefficient that meets the required flow and pressure-drop criteria. Of course, valve selection also required prior determination of the right valve type and pressure class, using other sections of this catalog. The tabulated C_v of the selected valve should then be used in the appropriate pressure drop or flow-rate equation to evaluate actual valve performance. At this stage, the checks described in section

Nomenclature (metric units in parentheses)

C_v	Valve flow coefficient
d	Valve inlet diameter, inches (mm)
F_L	Liquid pressure recovery coefficient, dimensionless
F_p	Piping geometry factor, dimensionless
G	Liquid specific gravity, dimensionless
G_v	Gas compressibility coefficient, dimensionless
k	Ratio of specific heats, dimensionless
K_i	Incipient cavitation coefficient, dimensionless
ΔP	Valve pressure drop, psi (bar)
ΔP_{CO}	Valve crack-open pressure drop, psi (bar)
ΔP_{FL}	Minimum valve pressure drop for full lift-psi (bar)
p_1	Valve inlet pressure, psia (bar, abs)
p_v	Liquid vapor pressure at valve inlet temperature-psia (bar, abs)
q	Volumetric flow rate, U.S. gpm (m^3/hr)

R_F	Ratio of sizing parameter to sizing parameter for full lift
R_p	Ratio of valve pressure drop to minimum pressure drop for full lift
R_1	Pressure drop ratio (gas or steam)
R_2	Pressure drop ratio (liquids)
SP	Valve sizing parameter
SP_{FL}	Valve sizing parameter for full lift
V	Fluid velocity at valve inlet, ft/sec (m/sec)
w	Weight flow rate-lb/hr (kg/hr)
x_T	Terminal value of $\Delta P/p_1$ for choked gas or steam flow, dimensionless
Y	Gas expansion factor, dimensionless
ρ	Weight density of fluid at valve inlet conditions, lb/ft ³ (kg/m ³)
Conversion factors are provided in the Conversion Factors section at the end of this catalog.	

2.2 should be made to correct for effects of large pressure drops if required.

As discussed below under flow-rate calculations, the flow-coefficient equations assume that the allowable pressure drop is available for the valve. Piping pressure drop should be addressed separately.

Caution: In applications of stop-check or check valves, the results of these equations will apply only if the valve is fully open. Always use the methods given in the Check Valve Sizing section (2.3) to ensure that the valve will be fully open or to make appropriate corrections.

2.2.3 Flow Rate

KNOWN:

Pressure drop (ΔP)
Fluid specific gravity (G) or density (ρ)
For water, steam or air, see Figures 21-23

FIND: Valve flow coefficient (C_v) from appropriate table

CALCULATE: Flow rate (w or q)

When the fluid properties and an allowable pressure drop are known, determine required coefficients for a specific valve and calculate the flow rate from the appropriate equation:

Equation 3a (U.S.)

$$q = F_p C_v \sqrt{\frac{\Delta P}{G}}$$

Equation 3b (metric)

$$q = 0.865 F_p C_v \sqrt{\frac{\Delta P}{G}}$$

Equation 3c (U.S.)

$$w = 63.3 F_p C_v \sqrt{\Delta P \rho}$$

Equation 3d (metric)

$$w = 27.3 F_p C_v \sqrt{\Delta P \rho}$$

2.2.4 Inlet Flow Velocity

KNOWN:

Flow rate (w or q)
Fluid specific gravity (G) or density (ρ)
For water, steam or air, see Figures 21-23

FIND: Valve inlet diameter (d) from appropriate table

CALCULATE: Fluid velocity at valve inlet (V)

While not normally required for valve sizing and selection, the fluid velocity at the valve inlet may be calculated from the appropriate equation:

Equation 4a (U.S.)

$$V = \frac{0.409q}{d^2}$$

Equation 4b (metric)

$$V = \frac{354q}{d^2}$$

Equation 4c (U.S.)

$$V = \frac{0.0509w}{\rho d^2}$$

Equation 4d (metric)

$$V = \frac{354w}{\rho d^2}$$

These valve flow-rate calculations are used less frequently than pressure drop and flow-coefficient calculations, but they are useful in some cases.

Caution: These equations assume that the pressure drop used for the calculation is available for the valve. In many piping systems with Edward Valves, flow is limited by pressure drop in pipe and fittings, so these equations should not be used as a substitute for piping calculations.

Use of these flow-rate equations for stop-check and check valves is not recommended unless the allowable pressure drop is relatively high (e.g., over about 10 psi or 0.7 bar). At lower values of ΔP , two or more different flow rates might exist, depending on whether or not the disk is fully open. Flow would vary depending on whether the pressure drop increased or decreased to reach the specified value.

Note: If a specific pipe inside diameter is known, that diameter may be used as the "d" value in the equation above to calculate the fluid velocity in the upstream pipe.

2.3 Corrections Required with Large Pressure Drops

While most Edward valves are used in relatively high-pressure systems and are usually sized to produce low pressure drop at normal

flow rates, care is necessary to avoid errors (which may be serious in some cases) due to flow "choking" (or near-choking). Problems arise most often at off-design flow conditions that exist only during plant start-up, shutdown, or standby operation.

Since steam and gas are compressible fluids, choking (or near-choking) may occur due to fluid expansion which causes the fluid velocity to approach or reach the speed of sound in reduced-area regions. While liquids are normally considered to be incompressible fluids, choking may also occur with liquid flow due to cavitation or flashing. In each case, simple calculations can be made to determine if a problem exists. Relatively simple calculations are required to correct for these effects. In some cases, these calculations may require a change in the size of type of valve required for a specific application.

The flow parameters K_v , F_p and x_p in the valve data tables assume that the valve is installed in pipe of the same nominal size. This is a fairly good assumption for preliminary calculations, but refer to the Pipe Reducer Coefficients section if there is a mismatch between valve and pipe diameters (also see instructions relative to F_p calculations in section 2.1) and make the appropriate corrections when final calculations are made.

Note: Because large pressure drop problems are not encountered frequently, equations are presented in terms of weight flow rate (w) and density (ρ) only. See the Conversion of Measurement Units section for converting other units of flow rate to weight flow rate.

2.3.1 Gas and Steam Flow

2.3.1.1 Pressure Drop

To determine if corrections are needed for compressible flow effects, use the data from the Basic Calculations to determine the ratio of the calculated pressure drop to the absolute upstream pressure:

Equation 5

$$R_1 = \frac{\Delta P}{p_1}$$

If the ratio R_1 is less than the values in Figure 14, the results of the Basic Calculations will usually be sufficiently accurate, and further calculations are unnecessary.

Figure 14 – Maximum $\Delta P/P_1$ for use of Basic Calculations Without Correction

Valve Type	Max. $\Delta P/P_1$
Gate	0.01
Inclined Bonnet Globe	0.02
Angle	
Tilting-Disk Check	
90° Bonnet Globe	0.05

If the pressure-drop ratio R_1 exceeds that tabulated for the valve type under evaluation, the procedure described below should be used to check and correct for possible flow choking or near-choking.

(1) Calculate the gas compressibility coefficient:

Equation 6 (U.S. or metric)

$$G_y = \frac{0.467}{kX_T} \left(\frac{\Delta P}{p_1} \right)$$

Note: The ΔP in this equation is the uncorrected value from the Basic Calculations. Values of x_r are given in valve data tables, and values of k are given in Figure 20.

(2) The next step depends on the value of G_y determined in equation 6:

• If $G_y < 0.148$, the flow is not fully choked. Read the value of Y from Figure 15 and calculate the corrected pressure drop:

Equation 7 (U.S. or metric)

$$\Delta P_c = \frac{\Delta P}{Y^2}$$

• If $G_y \geq 0.148$, the flow is choked. The desired flow cannot be achieved at the specified upstream pressure and will be limited to the choked flow rate given by:

Equation 8a (U.S.)

$$W_{\text{choked}} = 35.67 F_P C_V \sqrt{kX_T p_1 \rho}$$

Equation 8b (metric)

$$W_{\text{choked}} = 15.4 F_P C_V \sqrt{kX_T p_1 \rho}$$

• When flow is choked, the actual pressure drop cannot be calculated using valve flow calculations alone. It can be any value greater than the following minimum value for choked flow:

Equation 9 (U.S. or metric)

$$\Delta P_{\text{min. choked}} \geq 0.714 kX_T p_1$$

• The only way to determine the pressure downstream of a valve with choked flow is to calculate the pressure required to force the choked flow rate through the downstream piping. This may be done with piping calculations (not covered by this catalog).

2.3.1.2 Flow Rate

When calculating the flow rate through a valve, the actual pressure drop is known, but the flow may be reduced by choking or near-choking.

To check for high pressure-drop effects, calculate R_1 , the ratio of pressure drop to absolute upstream pressure (see equation 5 above) noting that the pressure drop in this case is the known value.

(1) Flow rates determined using the Basic Calculations are sufficiently accurate if R_1 is less than about twice the value tabulated in Figure 14 for the applicable valve type (higher because actual pressure drop is used in the ratio). In this case, no correction is necessary.

(2) When corrections for higher values of R_1 are required, calculate the gas expansion factor directly from:

Equation 10 (U.S. or metric)

$$Y = 1 - 0.467 \left(\frac{\Delta P/p_1}{kX_T} \right)$$

(3) The calculation method to determine the flow rate depends on the calculated value of Y from equation (10):

• If Y is greater than 0.667 (but less than 1), the flow is not fully choked. Calculate the corrected flow rate as follows:

Equation 11 (U.S. or metric)

$$W_c = YW$$

• If Y is equal to or less than 0.667, the valve flow is choked, and the results of the Basic Calculations are invalid. The actual flow rate may be calculated from the equation for W_{choked} [(8a) or (8b)] above.

Caution: Choked or near-choked flow conditions may produce significant flow-induced noise and vibration. Prolonged operation with flow rates in this region may also cause erosion damage within a valve or in downstream piping, particularly if the flow condition involve “wet” steam. Edward valves tolerate these conditions well in services involving limited time periods during plant start-up, shutdown, etc., but consult Flowserve about applications involving long exposure to such conditions.

2.3.2 Liquid Flow – Cavitation and Flashing

The fluid pressure in high-velocity regions within a valve may be much lower than either

Figure 15

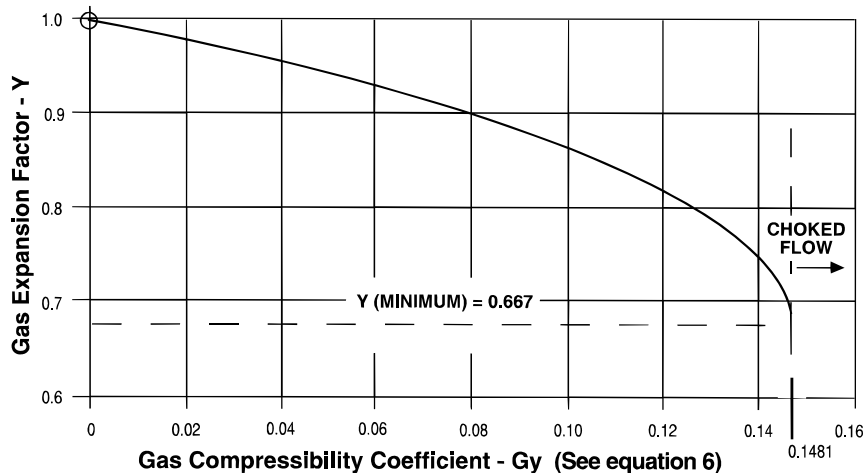

the upstream pressure or the downstream pressure. If the pressure within a valve falls below the vapor pressure (p_v) of the liquid, vapor bubbles or cavities may form in the flow stream. Cavitation, flashing and choking may occur. Use the equations and procedures in this section to evaluate these phenomena.

Cavitation and flashing are closely related, and they may be evaluated by calculating a pressure-drop ratio that is slightly different from that used for gas or steam:

Equation 12

$$R_1 = \frac{\Delta P}{(p_1 - p_v)}$$

To evaluate a particular valve and application, find values of K_i and F_L from the appropriate valve-data table, find \dot{P}_v values for common liquids given in Figure 24, calculate R_2 , and perform the following checks:

(1) Cavitation – the sudden and sometimes violent coalescence of the cavities back to the liquid state – occurs when the downstream pressure (within the valve or in the downstream pipe) recovers to above the vapor pressure.

- If $R_2 < K_i$, there should be no significant cavitation or effect on flow or pressure drop. Results of the Basic Calculations require no correction.

- If $R_2 > K_i$, cavitation begins. If the ratio is only slightly greater than K_i , it may be detected as an intermittent “ticking” noise near the valve outlet, although pipe insulation may muffle this sound. This stage of cavitation is usually related to tiny vapor cavities that form near the center of vortices in the flow stream, and it generally produces neither damage nor effects on flow characteristics. However, as the pressure drop ratio R_2 increases, the noise progresses to a “shh,” then a “roar.”

- If $R_2 > (K_i + FL_2)/2$, approximately, larger vapor cavities develop and the risk of cavitation damage (pitting) in the valve or downstream pipe may be a concern if this flow condition is sustained for significant periods of time. Noise may also pose a problem. Still, at this stage, there is usually no significant effect on valve flow characteristics. Results of the Basic Calculations require no correction.

As the pressure-drop ration increases beyond this point, some valves suffer slight reductions in their C_v values, but there is no practical way of correcting pressure drop

or flow calculations for this effect. Vibration and noise increase, ultimately sounding like “rocks and gravel” bouncing in the pipe at about the point where flow becomes choked.

(2) Flashing – the persistence of vapor cavities downstream of the valve — occurs when the pressure downstream of the valve remains below the vapor pressure.

- If $R_2 > 1$, flashing occurs, and the flow is choked due to vapor cavities in the flow stream.

(3) Liquid choking – A slightly different ratio may be used to predict the minimum pressure drop at choked flow conditions. Choking occurs due to vapor cavities near the minimum-area region in the flow stream when:

Equation 13

$$\frac{\Delta P}{(p_1 - 0.7p_v)} \geq F_L^2$$

Thus, the minimum pressure drop which will produce choked liquid flow is given by:

Equation 14

$$\Delta P \geq F_L^2 (p_1 - 0.7p_v)$$

Note that flow may be choked by either sever cavitation or flashing.

2.3.2.1 Predicting Choked Flow Rate

If the result of a Basic Calculation to determine pressure drop exceeds the value determined from equation (13), the Basic Calculation is invalid. the flow used for input cannot be obtained at the specified upstream pressure and temperature. In such a case, of if it is necessary to calculate liquid flow rate through a valve with high pressure drop, the choked flow rate at specified conditions may be calculated from:

Equation 15a (U.S.)

$$W_{\text{choked}} = 63.3F_P C_v F_L \sqrt{\rho(p_1 - 0.7p_v)}$$

Equation 15b (metric)

$$W_{\text{choked}} = 27.3F_P C_v F_L \sqrt{\rho(p_1 - 0.7p_v)}$$

When flow is choked due to either cavitating or flashing flow, the actual pressure drop cannot be determined from valve calculations. It may be any value greater than the minimum value for choked flow [equation (14)]. As in the case of choked gas or steam flow, the pressure downstream of a valve

must be determined by calculating the pressure required to force the choked flow through the downstream piping. This may be done with piping calculations (not covered by this catalog).

- If the pressure drop from a Basic Calculation was used to determine flow rate, and the pressure drop exceeds the pressure drop of choked flow, the result is invalid. The corrected flow rate may be calculated from equation (15a) or (15b) above.

2.4 Check Valve Sizing

The most important difference between check (including stop-check) valves and stop valves, from a flow performance standpoint, is that the check valve disk is opened only by dynamic forces due to fluid flow. The preceding calculation methods for flow and pressure drop are valid only if it can be shown that the valve is fully open.

The primary purpose of this section is to provide methods to predict check valve disk opening and to make corrections to pressure-drop calculations if the valve is not fully open. These methods are particularly applicable to sizing valves for new installations, but they are also useful for evaluation of performance of existing valves.

In selecting a stop-check or check valve for a new installation, the first steps require selecting a proper type and pressure class. The Stop and Check Valve Applications Guide section of this catalog should be reviewed carefully when the type is selected, noting advantages and disadvantages of each type and considering how they relate to the requirements of the installation. Other sections of this catalog provide pressure ratings to permit selection of the required pressure class.

2.4.1 Sizing Parameter

The first step in evaluating a stop-check or check valve application is to determine the Sizing Parameter based on the system flow rate and fluid properties:

Equation 16 (U.S. or metric)

$$SP = \frac{W}{\sqrt{\rho}}$$

Tables in this section provide a Sizing Parameter for full lift (SP_{FL}) for each Edward stop-check and check valve. The amount of opening of any check valve and its effect

on pressure drop can be checked simply as follows:

- If $SP_{FL} < SP$, the valve is fully open. Pressure drop may be calculated using the equations given previously for fully open valves (including corrections for large pressure drops if required).
- If $SP_{FL} > SP$, the valve is not fully open. A smaller size valve or another type should be selected if possible to ensure full opening. If that is not feasible, three additional steps are required to evaluate the opening and pressure drop of the valve under the specified service conditions.

Note: EPRI Report No. NP 5479 (Application Guideline 2.1) uses a "C" factor to calculate the minimum flow velocity required to fully open a check valve. The sizing procedures in this catalog do not employ the "C" factor, but values are given in the valve data tables for readers who prefer to use the EPRI methods. Since the EPRI methods are based on velocity, a flow area is required as a basis. Valve Inlet Diameters presented in data tables are the basis for correlation between flow rate and velocity.

2.4.2 Calculations for Check Valves Less Than Fully Open

If the preceding evaluation revealed an incompletely open check valve, perform the following additional calculations:

Calculate the flow-rate ratio:

Equation 17 (U.S. or metric)

$$R_F = \frac{SP}{SP_{FL}}$$

Determine the disk operating position:

Using the R_F value calculated above, determine the valve operating position from Figures 16-19 (cast-steel valves). Performance curve numbers for individual cast-steel stop-check and check valves are given in the tabulations with other coefficients. Evaluate the acceptability of the operating position based on recommendations in the Check Valve Applications Guide and in the specific sizing guidelines below.

Calculate the pressure drop:

Again using the R_F value calculated above, determine the pressure drop ratio R_p from Figures 16-19, and calculate the valve pressure drop at the partially open position:

Equation 18 (U.S. or metric)

$$\Delta P = R_p \Delta P_{FL}$$

Values for ΔP_{FL} for all stop-check and check valves are given in Valve Tables 1 to 5 and 10 to 15 with other coefficients.

Note: The values of the various valve coefficients given in the tabulations are based on testing of a substantial number of valves. Most are applicable to any line fluid, but those involving check valve lift are influenced by buoyancy. Tabulated values are based on reference test conditions with room-temperature water. SP_{FL} and ΔP_{FL} are slightly higher in applications involving lower-density line fluids. Considering the expected accuracy of these calculations, the following corrections may be considered:

- For water at any temperature and other common liquids – No correction required.
- For steam, air and other common gases at normal operating pressures and temperatures – Increase SP_{FL} by 7% and increase ΔP_{FL} by 14%.

2.4.3 Sizing Guidelines

Considering the recommendations in the Check Valve Applications Guide section of this catalog and the calculation methods described above, the following specific steps are recommended for sizing check valves for optimum performance and service life (it is assumed that the check valve type and pressure class have already been selected before starting this procedure):

(1) Constant flow rate – If the application involves a substantially constant flow rate during all operating conditions, the check valve should be sized to be fully open. This may be accomplished by the following procedure:

- Calculate the check valve sizing parameter (SP) for the application from equation (15). Values of density for water, steam, and air are available in Figures 21-23.

If the flow rate is not given in lb/hr (or kg/hr), refer to the Conversion of Measurement Units section of this catalog to make the necessary calculation.

- Select the valve size with the next smaller SP_{FL} value from valve data tables (Tables 1-5 for cast-steel valves). Make note of the C_{vT} , ΔP_{CO} , ΔP_{FL} , K_1 , F_L and x_T values for use in later calculations.

Note: Preferably, there should be a good margin between SP and SP_{FL} to be sure the valve will be fully open. In the specific case of tilting-disk check valves, it is recommended that SP_{FL} be less than 0.83 (SP) to be sure that the disk is fully loaded against its stop (particularly if it is close to a flow disturbance).

- Calculate the pressure drop using the Basic Calculation method in equation (1) and the C_{xx} value of the valve size selected above. Make the simple checks described above in section 2.2 (Corrections Required With Large Pressure Drops), and make appropriate cor-

rections in necessary (this is rarely needed for a valve sized for constant flow rate, but the check is desirable).

- Evaluate the pressure drop. If it is too high, a larger size or another check valve type should be tried. If it is lower than necessary for the application, a smaller and more economical valve (with a lower SP_{FL}) may be evaluated with assurance that it would also be fully open.
- Evaluate the crack-open pressure drop (ΔP_{CO}) to be certain that the system head available at the initiation of flow will initiate valve opening. Note that, for some valves, the crack-open pressure drop exceeds the pressure drop for full lift. Preceding calculations might indicate no problem, but it is possible that a valve might not open at all in a low-head application (e.g., gravity flow).

(2) Variable flow rate – If the application involves check valve operation over a range of flow rates, additional calculations are necessary to ensure satisfactory, stable performance at the lowest flow rate without causing excessive pressure drop at the maximum flow condition. This required careful evaluation of specific system operating conditions (e.g., are the minimum and maximum flow rates normal operating conditions or infrequent conditions that occur only during start-up or emergency conditions?).

The following options should be considered in selecting the best stop-check or check valve size for variable flow applications:

- The best method, if practical, is to size the valve to be fully open at the minimum flow condition. This may be done by following the first two steps listed above for the constant flow-rate case, but using the minimum flow rate in the sizing parameter (SP) calculation.

The only difference is that the pressure-drop calculations and evaluations in the third and fourth steps must be repeated at normal and maximum flow rates. If the selected valve size is fully open at the minimum flow rate and has an acceptable pressure drop at the maximum flow condition, it should give good overall performance.

- Sometimes a change in valve type provides the best cost-effective solution for variable-flow applications (e.g. use a smaller Flite-Flow® stop-check or check valve instead of a 90°-bonnet type to provide full lift at the minimum flow condition, but a high C_v for low pressure drop at maximum flow).

- Operation at less than full lift may have to be considered.

(3) Operation at less than full lift – “High Turndown” applications sometimes exist on boilers and other process systems that must swing through periodic flow changes from start-up, to standby, to maximum, and back again. In such cases, calculations may not reveal any single valve that will offer a satisfactory compromise assuring full lift and an acceptable pressure drop at both minimum and maximum flow conditions.

It may be acceptable to permit a check valve to operate at less than fully open at the minimum flow condition if such operation is infrequent or not expected to be sustained continuously for long periods. A valve may be sized by following the methods above using the lowest expected normal sustained flow rate in the sizing parameter (SP) calculation. Pressure drop at normal and maximum flow rates should then be calculated and evaluated.

The acceptability of valve operation at the minimum flow condition should be evaluated as follows:

- Calculate the sizing parameter (SP) at the minimum flow rate and the flow-rate ratio R_F from equation (17). The valve operating position (% open) should be determined from the proper performance curve (Figures 16-19).

Caution: Check valve operation at less than 25% opening is not recommended. Any check valve that operates for sustained periods at partial openings should be monitored or inspected periodically for evidence of instability or wear.

- If the minimum operating position is considered satisfactory, the pressure drop at the minimum flow condition may be calculated from equation (18), using the pressure-drop ratio (R_p) determined from the proper performance curve.

(4) Alternatives for high turndown applications – If the preceding steps show that the range of flow rates is too large for any single standard check valve, consult FlowsERVE. Several alternatives may be considered:

- Either 90°-bonnet or angle-type stop-check or piston-lift check valves may be furnished with a special disk with an extended “skirt” as illustrated in Figure 15A. This skirt increases flow resistance at low flow rates, producing additional lifting force to help prevent operation at small openings.

Of course, the skirt also reduces the C_v of the valve somewhat when it is fully open and increases pressure drop at maximum flow. Nevertheless, a special disk sometimes solves difficult high turndown problems. A special disk also permits solution of some problems with existing valves that are “oversized.”

- A stop-check valve may be used with the stem lifted just enough to provide a positive stop for the disk at very low flows (e.g., short-term start-up conditions). The stem should be lifted with increasing flow rate to maintain the disk-stopping action while preventing excessive pressure drop. At normal flow rates, the stem can be lifted to its fully open position, permitting normal check valve function. The stem may be actuated manually for infrequent start-up operations, or a motor actuator may be furnished for convenience if large flow rate variations are expected to be frequent.

Caution: This arrangement could produce cavitation or flow-choking problems if the flow rate is increased substantially without lifting the valve stem to compensate.

- A small check or stop-check valve may be installed in parallel with a larger stop-check valve. The smaller valve may be sized for the minimum flow condition, and the larger stop-check may be held closed with the stem until the flow is sufficient to ensure adequate lift. If necessary, the stem on the larger valve may be opened gradually with increasing flow to maintain disk-stopping action as in the example above. The smaller valve may be allowed to remain open at higher flow rates or, if a stop-check type is used, it may be closed if preferred. Either or both valves may be

manually actuated or furnished with a motor actuator for convenience.

2.5 Pipe Reducer Coefficient

The equations in the Flow Performance section of this catalog use a piping geometry factor, F_p , to account for the effect of pipe reducers attached directly to the valve. This permits the valve and pipe reducers to be treated as an assembly, i.e., $F_p C_v$ is the flow coefficient of the valve/pipe reducer combination. Then, the pressure drop in the flow equations is the pressure drop of the assembly.

This method is also applicable when valves are furnished with oversized ends to fit larger diameter pipe. It should also be used to evaluate line-size valves used in pipe with a lower pressure rating than the valve, because such pipe may have less wall thickness and a larger inside diameter than the valve inlet diameter given in the valve data tabulations.

This section provides equations for calculation of the piping geometry factor, F_p , which should be used even in Basic Calculations when there is a significant difference between the pipe diameter and valve inlet diameter (d).

In addition, other coefficients (K , F_L , x_T) are affected by the presence of pipe reducers. Equations are also provided for correction of these terms, which are required only when evaluating significant valve-to-pipe diameter mismatch.

Note: These equations apply only where the valve diameter is less than the connecting pipe diameter.

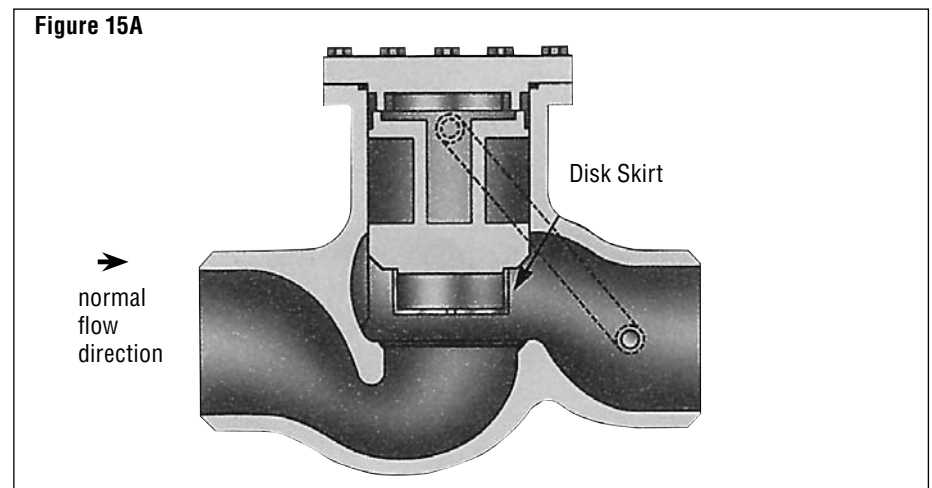

2.5.1 Pipe Geometry Factor

Calculate upstream loss coefficient:

Equation 1-1 (U.S. or metric)

$$K_1 = 0.5 \left[1 - \left(\frac{d}{D_1} \right)^2 \right]^2$$

Calculate downstream loss coefficient:

Equation 1-2 (U.S. or metric)

$$K_2 = \left[1 - \left(\frac{d}{D_2} \right)^2 \right]^2$$

Summation:

Equation 1-3 (U.S. or metric)

$$\sum K = K_1 + K_2$$

Equation 1-4a (U.S.)

$$F_p = \sqrt{1 + \frac{\sum K}{890} \left(\frac{C_v}{d^2} \right)^2}$$

Equation 1-4b (metric)

$$F_p = \sqrt{1 + 486 \sum K \left(\frac{C_v}{d^2} \right)^2}$$

Note: If D_1 and D_2 are not the same, use of F_p calculated in this manner accounts for energy losses associated with flow contraction and expansion, and the pressure drop calculated using this factor represents energy loss. Bernoulli effects may cause a different static pressure change between upstream and downstream pipes.

2.5.2 Other Coefficients

Correction of values of K_i , F_L and x_T requires an initial calculation of a Bernoulli coefficient to account for static pressure change in the inlet reducer:

Equation 1-5 (U.S. or metric)

$$K_{B1} = 1 - \left(\frac{d}{D_1} \right)^4$$

Then, corrected values of each coefficient may be calculated, using the corresponding value from valve data tables as input:

Equation 1-6a (U.S.)

$$K_{ii} = \frac{1}{F_p^2 \left[\frac{1}{K_i} + \left(\frac{K_1 + K_{B1}}{890} \right) \left(\frac{C_v}{d^2} \right)^2 \right]}$$

Equation 1-6b (metric)

$$K_{ii} = \frac{1}{F_p^2 \left[\frac{1}{K_i} + 468 (K_1 + K_{B1}) \left(\frac{C_v}{d^2} \right)^2 \right]}$$

Equation 1-7a (U.S.)

$$F_{LL} = \frac{1}{F_p \sqrt{\frac{1}{F_L^2} + \left(\frac{K_1 + K_{B1}}{890} \right) \left(\frac{C_v}{d^2} \right)^2}}$$

Equation 1-7b (metric)

$$F_{LL} = \frac{1}{F_p \sqrt{\frac{1}{F_L^2} + 468 (K_1 + K_{B1}) \left(\frac{C_v}{d^2} \right)^2}}$$

Equation 1-8a (U.S.)

$$x_{TT} = \frac{x_T}{F_p^2 \left[1 + \frac{x_T (K_1 + K_{B1})}{1000} \left(\frac{C_v}{d^2} \right)^2 \right]}$$

Equation 1-8b (metric)

$$x_{TT} = \frac{x_T}{F_p^2 \left[1 + 416 x_T (K_1 + K_{B1}) \left(\frac{C_v}{d^2} \right)^2 \right]}$$

where: K_i , F_L and x_T are values from valve data tables; K_{ii} , F_{LL} and x_{TT} are corrected values for valve/reducer assembly.

Nomenclature

C_v	valve flow coefficient. See Valve Reference Data.
d	valve-end inside diameter, inches, (mm). See Valve Reference Data.
D_1	inside diameter of upstream pipe, inches, (mm). See Pipe Data Section.
D_2	inside diameter of downstream pipe, inches, (mm). See Pipe Data Section.
F_L	liquid-pressure recovery coefficient, dimensionless*
F_p	piping-geometry factor, dimensionless
K_1	pressure-loss coefficient for inlet reducer, dimensionless
K_2	pressure-loss coefficient for outlet reducer, dimensionless
K_{B1}	pressure change (Bernoulli) coefficient for inlet reducer, dimensionless
$\sum K$	$K_1 + K_2$, dimensionless
K_i	incipient-cavitation coefficient, dimensionless*
x_T	terminal value of $\Delta P/p_1$ for choked gas or steam flow, dimensionless

*Double subscripts (e.g. K_{ii}) represent values corrected for effects of pipe reducers.

Table 1 – Edward Cast Steel Globe Flow Coefficients

Black numerals are in U.S. customary units or dimensionless
Colored numerals are in metric units

Size		All Stop and Check Valves					Check Valve Coefficients				Perf. Curves Fig. 16
NPS	DN	C_v	F_L	x_T	K_I	d	ΔP_{CO}	ΔP_{FL}	SP_{FL}	C	

Class 300 (PN 50) Figure No. 318/318Y Stop valves, 304/304Y Stop-Check valves, 394/394Y Check valves

2.5	65	110	0.53	0.34	0.20	2.50	63.5	0.58	0.040	0.31	0.021	5630	637	46	4
3	80	84	0.80	0.43	0.06	3.00	76.2	0.79	0.054	1.3	0.088	5990	679	34	4
4	100	120	0.79	0.43		4.00	102	0.80	0.055	1.4	0.095	8980	1020	29	4
5	125	215	0.79	0.43		5.00	127	0.97	0.067	1.8	0.12	18,100	2050	37	4
6	150	335	0.80	0.44		6.00	152	1.2	0.084	2.3	0.16	31,900	3610	45	1
8	200	580	0.76	0.39		8.00	203	1.2	0.086	1.2	0.085	40,800	4620	33	1
10	250	1000	0.77	0.40		10.00	254	1.2	0.081	1.1	0.079	67,600	7660	34	1
12	300	1550	0.77	0.40		12.00	305	1.3	0.092	1.2	0.084	107,000	12,100	38	1

Class 600 (PN 110) Figure No. 616/616Y, 618/618Y, 716Y Stop valves, 606/604Y, 706Y Stop-Check valves, 694/694Y, 690/690Y, 794Y Check valves

2.5	65	84	0.97	0.61	0.10	2.50	63.5	0.79	0.054	1.3	0.088	5990	679	49	4
3	80	120	0.97	0.61		3.00	76.2	0.80	0.055	1.4	0.095	8980	1020	51	4
4	100	215	0.97	0.60		4.00	102	0.97	0.067	1.8	0.12	18,100	2050	58	4
5	125	335	0.97	0.61		5.00	127	1.2	0.084	2.3	0.16	31,900	3610	65	4
6	150	580	0.81	0.42	0.07	6.00	152	1.2	0.086	1.2	0.085	40,800	4620	58	1
8	200	1000	0.81	0.42		7.87	200	1.2	0.081	1.1	0.079	67,600	7660	56	1
10	250	1550	0.81	0.42		9.75	248	1.3	0.092	1.2	0.084	107,000	12,100	57	1
12	300	2200	0.81	0.42		11.75	298	1.5	0.10	1.4	0.099	169,000	19,100	62	1
14	350	2650	0.81	0.42		12.87	327	1.6	0.11	1.5	0.10	205,000	23,200	63	1

Class 900 (PN 150) Figure No. 4016/4016Y, 4316Y Stop valves, 4006/4006Y, 4306Y Stop-Check valves, 4094/4094Y, 4394Y Check valves

3	80	110	0.96	0.60	0.10	2.87	72.9	0.92	0.063	1.5	0.10	8510	964	53	4
4	100	200	0.97	0.60		3.87	98.2	1.3	0.090	2.3	0.16	19,500	2210	66	5
5	125	305	0.97	0.61		4.75	121	1.3	0.092	2.5	0.18	30,600	3470	69	4
6	150	530	0.81	0.42	0.07	5.75	146	1.2	0.085	1.5	0.10	41,500	4700	64	3
8	200	910	0.81	0.42		7.50	191	1.3	0.093	1.5	0.10	69,500	7870	63	2
10	250	1400	0.81	0.42		9.37	238	1.6	0.11	1.8	0.12	119,000	13,500	69	1
12	300	2000	0.81	0.42		11.12	282	1.8	0.12	2.1	0.14	182,000	20,600	75	2
14	350	2400	0.81	0.42	12.25	311	1.6	0.11	1.9	0.13	211,000	23,900	72	2	

See note following section 2.4.1 for discussion of C factor.



**Table 1 – Edward Cast Steel Globe
Flow Coefficients**

Black numerals are in U.S. customary units or dimensionless
Colored numerals are in metric units

Size		All Stop and Check Valves					Check Valve Coefficients					Perf. Curves Fig. 16			
NPS	DN	C_v	F_L	x_T	K_I	d	ΔP_{CO}	ΔP_{FL}	SP_{FL}	C					
Class 1500 (PN 260) Figure No. 2016, 7516/7516Y Stop valves, 2006Y, 7506/7506Y Stop-Check valves, 2094Y, 7594/7594Y Check valves															
2.5	65	72	0.92	0.54	0.08	2.25	57.2	0.76	0.052	1.3	0.091	5230	592	53	5
3	80	110	0.89	0.51		2.75	69.9	0.92	0.063	1.5	0.10	8510	964	57	4
4	100	200	0.85	0.47		3.62	91.9	1.3	0.088	2.3	0.16	19,300	2190	75	5
5	125	300	0.83	0.44	0.07	4.37	111	1.2	0.080	2.2	0.15	28,600	3240	76	4
6	150	465	0.80	0.42		5.37	136	1.4	0.094	1.4	0.096	35,000	3960	62	2
8	200	790	0.81	0.42		7.00	178	1.6	0.11	1.4	0.097	59,300	6720	62	1
10	250	1250	0.81	0.42		8.75	222	1.5	0.10	1.4	0.100	93,900	10,600	63	1
12	300	1750	0.81	0.42		10.37	263	1.5	0.11	1.8	0.12	147,000	16,600	70	3
14	350	2100	0.81	0.42		11.37	289	1.7	0.12	2.1	0.14	190,000	21,500	75	3

Class 2500 (PN 420) Figure No. 3916/3916Y, 4416Y Stop valves, 3906/3906Y, 4406Y Stop-Check valves, 3994/3994Y, 4494Y Check valves															
2.5	65	47	0.97	0.60	0.10	1.87	47.5	1.1	0.075	1.3	0.088	3370	382	49	6
3	80	68	0.97	0.61		2.25	57.2	1.4	0.093	1.6	0.11	5480	620	55	6
4	100	110	0.96	0.60		2.87	72.9	0.96	0.066	1.4	0.095	8280	938	51	5
5	125	175	0.97	0.60	0.07	3.62	91.9	1.4	0.097	2.2	0.15	16,600	1880	65	5
6	150	310	0.81	0.42		4.37	111	1.5	0.11	1.6	0.11	24,600	2790	66	3
8	200	530	0.81	0.42		5.75	146	2.2	0.15	2.2	0.15	49,800	5640	77	2
10	250	845	0.81	0.42		7.25	184	1.5	0.10	1.5	0.11	66,600	7540	65	2
12	300	1200	0.81	0.42		8.62	219	1.6	0.11	1.7	0.11	97,700	11,100	67	3

See note following section 2.4.1 for discussion of C factor.

Figure 16 – Edward Cast Steel Globe Piston Lift Check Valve Performance Curves

Figure 16A

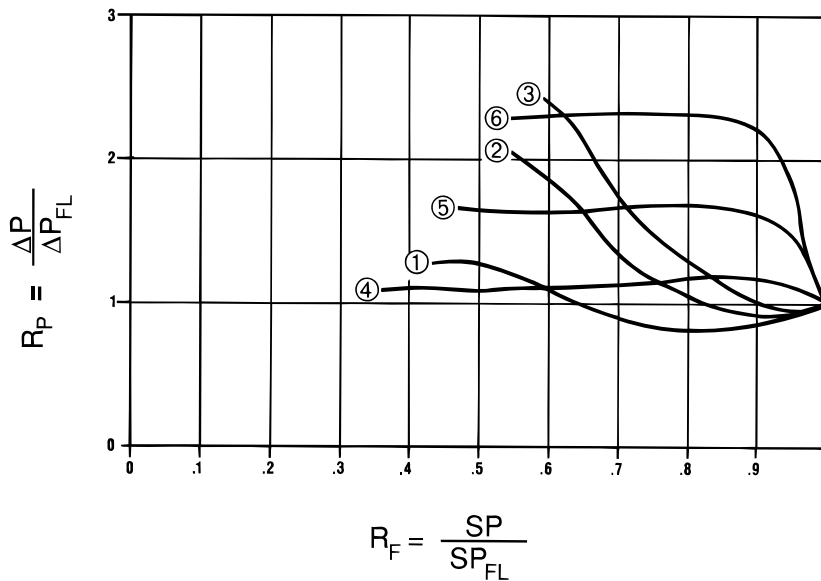
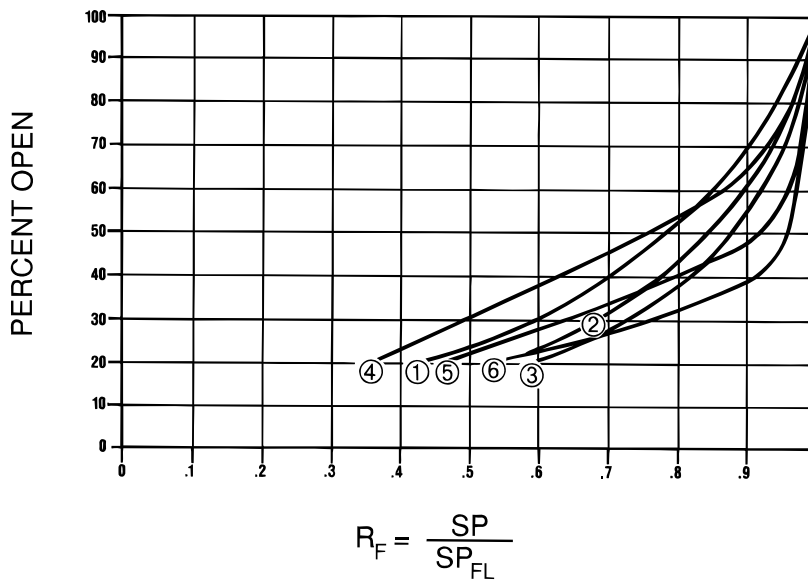

Figure 16B





**Table 2 – Edward Cast Steel Angle Valve
Flow Coefficients**

Black numerals are in U.S. customary units or dimensionless
Colored numerals are in metric units

Size		All Stop and Check Valves					Check Valve Coefficient					Perf. Curves Fig. 16			
NPS	DN	C_v	F_L	x_T	K_I	d	ΔP_{CO}	ΔP_{FL}	SP_{FL}	C					
Class 300 (PN 50) Figure No. 319/319Y/329/329Y, Stop valves, 303/303Y, Stop-Check valves, 391/391Y/393/393Y Check valves															
2.5	65	110	0.53	0.34	0.15	2.50	63.5	0.63	0.043	0.46	0.032	4940	559	40	5
3	80	135	0.59	0.24	0.07	3.00	76.2	0.79	0.054	0.55	0.038	6300	714	36	5
4	100	195	0.58	0.23		4.00	102	0.80	0.055	0.59	0.041	9460	1070	30	5
5	125	345	0.59	0.23		5.00	127	0.97	0.067	0.75	0.052	18,900	2140	39	4
6	150	535	0.59	0.24		6.00	152	1.2	0.084	0.96	0.066	33,200	3760	47	1
8	200	860	0.59	0.23		8.00	203	1.2	0.086	0.75	0.052	47,200	5340	38	1
10	250	1500	0.59	0.23		10.00	254	1.2	0.081	0.70	0.048	78,200	8860	40	1
12	300	2250	0.59	0.23		12.00	305	1.3	0.092	0.74	0.051	124,000	14,000	44	1

Class 600 (PN 110) Figure No. 617/617Y, 619/619Y, 717Y Stop valves, 605/605Y, 607/607, 707Y Stop-Check valves, 691/691Y, 695/695Y, 795Y Check valves															
2.5	65	135	0.62	0.25	0.08	2.50	63.5	0.79	0.054	0.55	0.038	6300	714	51	5
3	80	195	0.62	0.25		3.00	76.2	0.80	0.055	0.59	0.041	9460	1070	54	5
4	100	345	0.62	0.25		4.00	102	0.97	0.067	0.75	0.051	18,800	2130	60	4
5	125	535	0.62	0.25		5.00	127	1.2	0.084	0.96	0.066	32,200	3760	68	4
6	150	860	0.64	0.25		6.00	152	1.2	0.086	0.75	0.052	47,200	5340	67	1
8	200	1500	0.63	0.25		7.87	200	1.2	0.081	0.70	0.048	78,200	8860	64	1
10	250	2250	0.63	0.25		9.75	248	1.3	0.092	0.74	0.051	124,000	14,000	66	1
12	300	3300	0.63	0.25		11.75	298	1.5	0.10	0.88	0.061	196,000	22,200	72	1
14	350	3950	0.63	0.25		12.87	327	1.6	0.11	0.90	0.062	237,000	26,900	73	1

Class 900 (PN 150) Figure No. 4017/4017Y, 4317Y Stop valves, 4007/4007Y, 4307Y Stop-Check valves, 4095/4095Y, 4395Y Check valves															
3	80	180	0.62	0.24	0.08	2.87	72.9	0.92	0.063	0.64	0.044	8980	1020	56	5
4	100	325	0.62	0.25		3.87	98.2	1.5	0.10	1.2	0.081	22,200	2510	75	5
5	125	485	0.63	0.25		4.75	121	1.2	0.083	1.0	0.072	31,200	3530	70	5
6	150	790	0.63	0.25		5.75	146	1.3	0.092	1.0	0.071	50,900	5770	78	3
8	200	1350	0.63	0.25		7.50	190	1.4	0.099	1.0	0.071	86,600	9810	78	3
10	250	2100	0.63	0.25		9.37	238	1.7	0.12	1.3	0.090	152,000	17,200	88	3
12	300	2950	0.63	0.25		11.12	282	1.8	0.13	1.4	0.093	218,000	24,700	90	2
14	350	3600	0.63	0.25	12.25	311	1.5	0.10	1.3	0.091	261,000	29,600	89	2	
16	400	6450	0.56	0.19	0.06	14.00	356	1.9	0.13	0.74	0.051	350,000	39,700	91	2
18	450	*	*	*		15.75	400	*	*	*	*	*	*	*	*
20	500	10,000	0.56	0.19		17.50	444	1.7	0.11	0.76	0.052	553,000	62,600	92	3
24	600	14,500	0.56	0.19		21.00	533	2.6	0.18	1.1	0.073	940,000	106,000	109	3

See note following section 2.4.1 for discussion of C factor.

Table 2 (continued) – Edward Cast Steel Angle Valve Flow Coefficients

Black numerals are in U.S. customary units or dimensionless
Colored numerals are in metric units

Size		All Stop and Check Valves					Check Valve Coefficients					Perf. Curves Fig. 16
NPS	DN	C_v	F_L	x_T	K_I	d	ΔP_{CO}	ΔP_{FL}	SP_{FL}	C		

Class 1500 (PN 260) Figure No. 2017Y, 7517/7517Y Stop valves, 2007Y, 7507/7507Y Stop-Check valves, 2095Y, 7595/7595Y Check valves

2.5	65	115	0.59	0.22	0.06	2.25	57.2	0.75	0.052	0.58	0.040	5560	630	56	6
3	80	180	0.57	0.21		2.75	69.9	0.92	0.063	0.64	0.044	8980	1020	60	5
4	100	320	0.55	0.19		3.62	91.9	1.50	0.10	1.20	0.081	22,000	2490	86	5
5	125	475	0.54	0.18		4.37	111	1.30	0.093	1.20	0.083	33,000	3740	88	5
6	150	690	0.63	0.25	0.08	5.37	136	1.50	0.10	1.00	0.069	43,800	4970	77	3
8	200	1150	0.63	0.25		7.00	178	1.60	0.11	0.99	0.068	73,900	8370	77	3
10	250	1850	0.63	0.25		8.75	222	1.60	0.11	1.20	0.083	127,000	14,400	85	3
12	300	2550	0.63	0.25		10.37	263	1.80	0.13	1.40	0.094	190,000	21,500	90	3
14	350	3100	0.63	0.25	0.06	11.37	289	1.70	0.12	1.30	0.091	225,000	25,500	89	3
16	400	5550	0.56	0.19		13.00	330	2.00	0.14	0.79	0.055	313,000	35,400	94	3
18	450	5350	0.54	0.19		14.62	371	2.00	0.14	0.86	0.059	313,000	35,400	75	3
20	500	*	*	*		*	16.37	416	*	*	*	*	*	*	*
24	600	*	*	*	*	19.62	498	*	*	*	*	*	*	*	*

Class 2500 (PN 420) Fig. No. 3917/3917Y, 4417Y Stop valves, 3907/3907Y, 4407Y Stop-Check valves, 3995/3995Y, 4495Y Check valves

2.5	65	75.5	0.62	0.24	0.08	1.87	47.5	1.1	0.075	0.57	0.039	3610	409	53	6
3	80	110	0.62	0.24		2.25	57.2	1.3	0.091	0.69	0.048	5770	653	58	6
4	100	180	0.62	0.24		2.87	72.9	0.96	0.066	0.61	0.042	8810	998	55	6
5	125	280	0.62	0.25		3.62	91.9	1.4	0.097	0.97	0.067	17,600	1990	68	5
6	150	455	0.63	0.25		4.37	111	1.5	0.11	0.96	0.066	28,300	3210	76	2
8	200	790	0.63	0.25		5.75	146	2.3	0.16	1.4	0.096	59,000	6680	91	2
10	250	1250	0.64	0.25		7.25	184	1.5	0.10	0.93	0.064	76,500	8660	74	2
12	300	1750	0.63	0.25		8.62	219	1.8	0.13	1.3	0.088	127,000	14,400	87	3
14	350	3400	0.40	0.10	0.05	9.50	241	2.1	0.14	0.89	0.061	204,000	23,100	115	3
16	400	3500	0.54	0.18		10.87	276	2.1	0.14	0.85	0.058	204,000	23,100	88	3
18	450	5450	0.50	0.15		12.25	311	2.5	0.17	1.00	0.069	347,000	39,300	118	3
20	500	5500	0.55	0.18		13.50	343	2.5	0.17	1.00	0.070	351,000	39,800	98	3
22	550	6900	0.55	0.18		14.87	378	2.5	0.17	0.97	0.067	429,000	48,600	99	3
24	600	*	*	*		*	*	*	*	*	*	*	*	*	*

See note following section 2.4.1 for discussion of C factor.
* Consult Flowserve Edward Valves Sales Representative

Figure 17 – Edward Cast Steel Angle Piston Lift Check Valve Performance Curves

Figure 17A

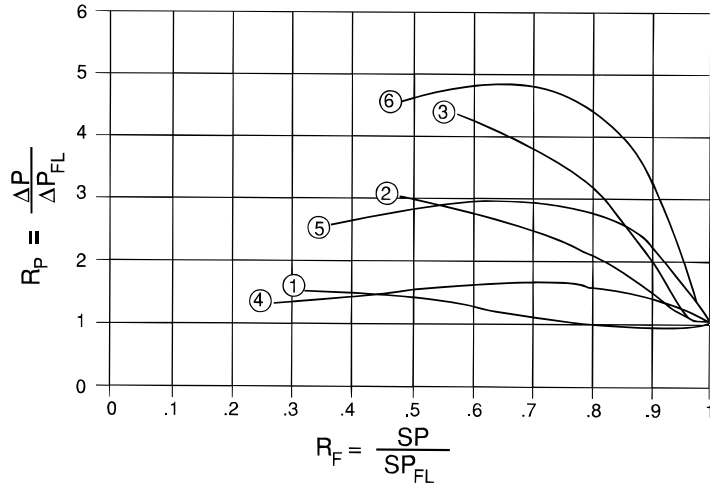

Figure 17B

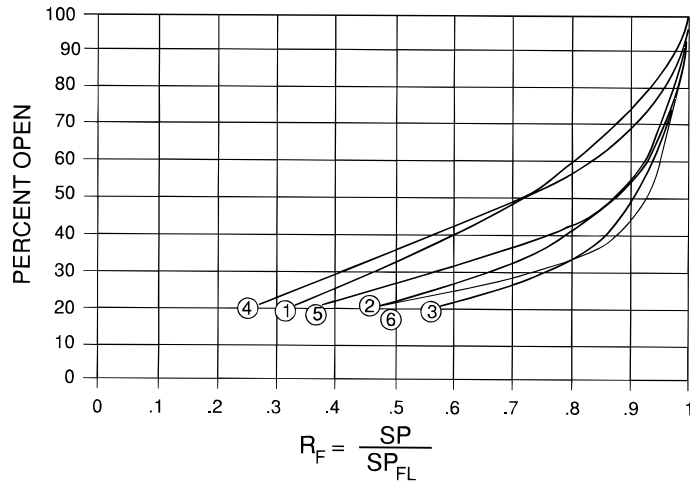

Table 3 – Edward Cast Steel Flite-Flow® Stop and Stop-Check Valve Flow Coefficients

Black numerals are in U.S. customary units or dimensionless
Colored numerals are in metric units

Size		All Stop and Check Valves						Check Valve Coefficients				Perf. Curves Fig. 16
NPS	DN	C _v	F _L	x _T	K _i	d	ΔP _{CO}	ΔP _{FL}	SP _{FL}	C		

Class 300/400 (PN 50/68) Figure No. 1314, 1314Y, 1329, 1329Y Stop valves; 1302, 1302Y Stop-Check valves; 1390, 1390Y, 1392, 1392Y Piston Lift Check valves

2-½	65	110	0.53	0.34	0.02	2.50	64	0.9	0.06	0.91	0.063	6,750	765	55	1, 2
3	80	295	0.52	0.20	0.08	3.00	76	0.8	0.06	0.64	0.044	15,000	1,680	85	4, 4
4	100	525	0.52	0.20	0.08	4.00	102	0.8	0.06	0.66	0.046	27,000	3,070	86	4, 4
6	150	1,200	0.52	0.20	0.08	6.00	152	0.7	0.05	0.71	0.049	63,000	7,120	89	4, 4
8	200	2,100	0.52	0.20	0.08	8.00	200	0.9	0.06	0.67	0.046	109,000	12,400	87	4, 4
10	250	3,300	0.52	0.20	0.08	10.00	248	1.0	0.07	0.76	0.052	181,000	20,500	92	4, 4
12	300	4,750	0.52	0.20	0.08	12.00	305	1.1	0.08	0.87	0.060	279,000	31,500	99	4, 4
14	350	4,750	0.52	0.20	0.08	12.00	305	1.1	0.08	0.87	0.060	279,000	31,500	99	4, 4
16	400	4,750	0.53	0.22	0.09	12.00	305	1.5	0.10	0.87	0.060	279,000	31,500	99	4, 4

Class 600/700 (PN 110/120) Figure No. 614, 614Y, 714Y Stop valves; 602, 602Y, 702Y Stop-Check valves; 692, 692Y, 792Y Piston Lift Check valves

3	80	295	0.52	0.20	0.08	3.00	76.2	0.8	0.06	0.44	0.030	12,400	1,400	70	4, 4
4	100	525	0.52	0.20	0.08	4.00	102	0.8	0.06	0.47	0.032	22,900	2,590	73	4, 4
6	150	1,200	0.52	0.20	0.08	6.00	152	0.7	0.05	0.53	0.037	54,500	6,170	77	4, 4
8	200	2,050	0.52	0.20	0.08	7.87	200	0.9	0.06	0.68	0.047	106,000	12,000	87	4, 4
10	250	3,100	0.52	0.20	0.08	9.75	248	1.0	0.07	0.85	0.059	182,000	20,600	98	4, 4
12	300	4,550	0.52	0.20	0.08	11.75	298	1.1	0.08	0.96	0.066	281,000	31,800	104	4, 4
14	350	4,550	0.52	0.20	0.08	11.75	298	1.1	0.08	0.96	0.066	281,000	31,800	104	4, 4
16	400	7,150	0.56	0.19	0.04	14.75	375	1.5	0.10	1.05	0.072	463,000	52,400	108	4, 4
20	500	11,000	0.52	0.20	0.08	18.25	484	1.4	0.10	0.96	0.066	677,000	76,700	104	1, 1
24	600	16,000	0.56	0.19	0.04	22.00	558	1.2	0.08	0.86	0.076	935,000	106,000	98	1, 2

Class 900/1100 (PN 150/190) Figure No. 4014, 4014Y, 4314Y Stop valves; 4002, 4002Y, 4302Y Stop-Check valves; 4092, 4092Y, 4392Y Piston Lift Check valves

3	80	270	0.52	0.02	0.08	2.87	72.9	0.9	0.06	0.52	0.036	12,400	1,400	77	4, 4
4	100	490	0.52	0.02	0.08	3.87	98.2	0.9	0.06	0.53	0.037	22,600	2,550	77	4, 4
6	150	1,100	0.52	0.02	0.08	5.75	146	0.7	0.05	0.50	0.034	48,500	5,490	75	4, 4
8	200	1,850	0.52	0.02	0.08	7.50	191	0.8	0.06	0.65	0.045	94,200	10,700	85	4, 4
10	250	2,900	0.52	0.02	0.08	9.37	238	1.0	0.07	0.84	0.058	167,000	18,900	97	4, 4
12	300	4,050	0.52	0.02	0.08	11.12	282	1.1	0.08	0.93	0.064	248,000	28,100	102	4, 4
14	350	4,050	0.52	0.02	0.08	11.12	282	1.1	0.08	0.93	0.064	248,000	28,100	102	4, 4
16	400	6,450	0.52	0.02	0.08	14.00	356	1.3	0.09	1.09	0.075	426,000	48,200	111	4, 4

See note following section 2.4.1 for discussion of C factor.

* Consult Flowserve Edward Valves Sales Representative



Table 3 (continued) – Edward Cast Steel Flite-Flow® Stop and Stop-Check Valve Flow Coefficients

Black numerals are in U.S. customary units or dimensionless
Colored numerals are in metric units

Size		All Stop and Check Valves					Check Valve Coefficients					Perf. Curves Fig. 16
NPS	DN	C _v	F _L	x _T	K _i	d	ΔP _{CO}	ΔP _{FL}	SP _{FL}	C		

Class 1500/1800 (PN 260/310) Figure No. 2014Y, 7514Y Stop valves; 2002Y, 7502Y Stop-Check valves; 2092Y, 7592Y Check valves

3	80	270	0.52	0.20	0.08	2.87	72.9	1.0	0.07	0.51	0.035	12,200	1,380	75	4, 4
4	100	425	0.52	0.20		3.62	91.9	1.0	0.07	0.62	0.043	21,200	2,400	82	4, 4
6	150	950	0.61	0.23		5.37	136	1.3	0.09	0.73	0.050	51,200	5,800	90	1, 3
8	200	1,600	0.61	0.23		7.00	178	1.5	0.10	0.74	0.051	87,800	9,940	91	1, 2
10	250	2,500	0.61	0.23	0.05	8.75	222	1.5	0.10	0.89	0.061	150,000	17,000	100	1, 2
12	300	3,550	0.61	0.23		10.37	263	1.7	0.12	1.01	0.070	225,000	25,500	107	1, 2
14	350	3,550	0.59	0.22		10.37	263	1.7	0.12	1.01	0.070	225,000	25,500	106	1, 2
16	400	5,550	0.61	0.23		13.00	330	1.8	0.12	1.09	0.075	366,000	41,500	110	1, 2
18	450	5,550	0.59	0.22		13.00	330	1.8	0.12	1.09	0.075	366,000	41,500	110	1, 2
20	500	8,800	0.61	0.23		16.37	416	2.2	0.15	1.46	0.101	673,000	76,200	128	1, 2
24	600	8,800	0.59	0.23	0.06	16.37	416	2.3	0.16	*	*	*	*	*	*

Class 2500/2900 (PN 460/490) Figure No. 3914Y, 4414Y Stop valves, 3902Y, 4402Y Stop-Check valves, 3992Y, 4492Y Check valves

Class 2900 (PN 490) Size 3 and 4 only with figure numbers the same as Class 2500 valves.

3	80	165	0.52	0.20	0.08	2.25	57.2	1.1	0.08	0.71	0.049	8,850	1,000	89	4, 4
4	100	270	0.52	0.20		2.87	72.9	0.9	0.06	0.70	0.048	14,300	1,620	88	4, 4
6	150	625	0.61	0.23		4.37	111	1.5	0.11	0.84	0.058	36,300	4,110	97	1, 2
8	200	1,100	0.61	0.23		5.75	146	2.1	0.15	1.13	0.078	73,000	8,270	112	1, 2
10	250	1,750	0.61	0.22	0.05	7.25	184	1.5	0.10	0.80	0.055	97,600	11,100	95	1, 2
12	300	2,450	0.61	0.22		8.62	219	1.7	0.12	0.96	0.066	151,000	17,100	103	1, 3
14	350	3,550	0.53	0.17		10.37	263	1.9	0.13	1.17	0.081	242,000	27,400	115	1, 2
16	400	3,550	0.60	0.22		10.37	263	1.9	0.13	1.17	0.081	242,000	27,400	115	1, 2
18	450	5,550	0.55	0.18		13.00	330	2.3	0.16	1.38	0.095	412,000	46,700	124	1, 2
20	500	5,550	0.54	0.18		13.00	330	2.3	0.16	1.38	0.095	412,000	46,700	124	1, 2
24	600	8,100	0.60	0.22		15.69	399	2.4	0.17	1.61	0.111	648,000	73,400	134	1, 2

Series 4500 Figure No. 4514Y, 5014Y Stop valves, 4502Y, 5002Y Stop-Check valves, 4592Y, 5092Y Check valves

4	100	135	0.66	0.26	0.06	2.37	60.2	1.2	0.08	0.97	0.067	8,290	939	75	1, 2
6	150	305	0.64	0.24		3.37	85.6	1.5	0.10	1.75	0.121	25,300	2,870	113	1, 2
8	200	740	0.48	0.14	0.3	4.75	121	2.3	0.16	0.83	0.057	42,800	4,840	97	1, 2
10	250	1,100	0.51	0.16		5.75	146	1.7	0.12	0.86	0.059	63,600	7,200	98	1, 3

See note following section 2.4.1 for discussion of C factor.

* Consult Flowserve Edward Valves Sales Representative.

Table 3 (continued) – Edward Cast Steel Flite-Flow® Stop and Stop-Check Valve Flow Coefficients

Black numerals are in U.S. customary units or dimensionless
Colored numerals are in metric units

Size		All Stop and Check Valves					Check Valve Coefficients					Perf. Curves Fig. 16
NPS	DN	C _v	F _L	x _T	K _i	d	ΔP _{co}	ΔP _{FL}	SP _{FL}	C		

Class 2000 (PN 340) Figure No. 2214Y, 3214Y Stop valves; 2002Y, 3202Y Stop-Check valves; 2292Y, 3292Y Check valves

12	300	2950	0.52	0.20	0.08	9.50	241	1.7	0.12	0.85	0.059	172,600	19,500	97	4, 4
14	350	2950	0.52	0.20		9.50	241	1.7	0.12	0.85	0.059	172,600	19,500	97	4, 4

Figure 18 – Cast Steel Flite-Flow® Piston Lift Check Valve Performance Curves

Figure 18A

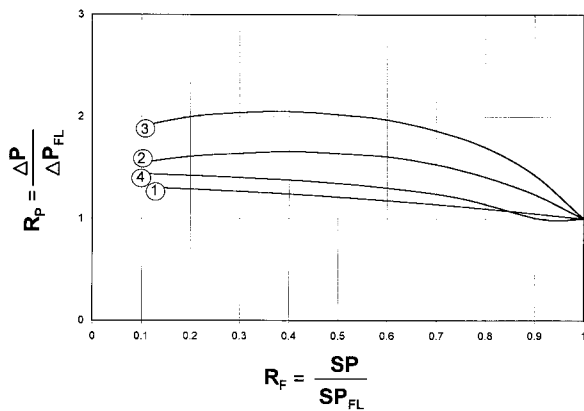

Figure 18B

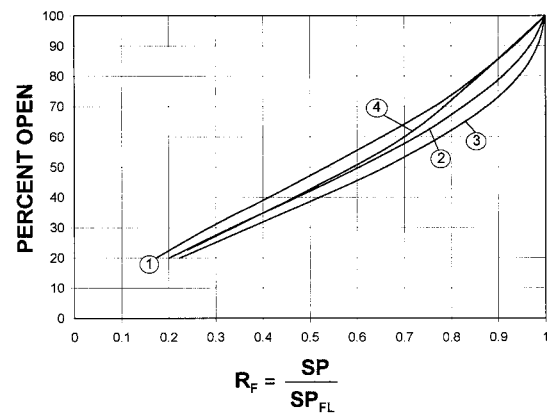



Table 4 – Edward Cast Steel Tilting Disk Check Valve Flow Coefficients¹

Black numerals are in U.S. customary units or dimensionless
Colored numerals are in metric units

Size		Check Valve Flow Coefficients					Check Valve Coefficients					Perf. Curves Fig. 19
NPS	DN	C _v	F _L	x _T	K _i	d	ΔP _{FL}	K _i	SP _{FL}	C		

Class 600 (PN 110) Figure No. 670Y, 770Y

6	150	1110	0.57	0.20	0.05	6.00	152	0.80	0.055	62,300	7,060	88	1
8	200	1850	0.57	0.20		7.87	200	1.0	0.069	115,000	13,000	95	1
10	250	2850	0.57	0.20		9.75	248	1.1	0.076	187,000	21,200	100	1
12	300	4100	0.57	0.20		11.75	298	1.2	0.083	285,000	32,300	105	1
14	350	4050	0.56	0.20		12.87	327	1.2	0.083	285,000	32,300	88	1
16	400	6500	0.57	0.20		14.75	375	1.4	0.097	481,000	54,500	113	1
18	450	8100	0.57	0.20		16.50	419	1.5	0.10	622,000	70,500	116	1
20	500	9950	0.57	0.20		18.25	464	1.6	0.11	786,000	89,000	120	1

Class 900 (PN 150) Figure No. 970Y, 4370Y

2.5	65	195	0.44	0.12	0.02	2.25	57.2	1.0	0.069	12,200	1,380	123	1
3	80	245	0.57	0.20	0.05	2.87	72.9	0.60	0.041	12,200	1,380	75	1
4	100	215	0.59	0.23		3.87	98.2	0.80	0.055	12,200	1,380	41	1
6	150	990	0.57	0.20		5.75	146	0.80	0.055	56,800	6,430	87	1
8	200	1700	0.57	0.20		7.50	190	0.80	0.055	97,000	11,000	88	2
10	250	2400	0.56	0.20		9.37	238	0.90	0.062	145,000	16,400	84	2
12	300	3450	0.56	0.20		11.12	282	1.1	0.076	233,000	26,400	96	1
14	350	3300	0.56	0.20		12.25	311	1.3	0.090	233,000	26,400	79	1
16	400	4950	0.56	0.20		14.00	356	1.3	0.090	360,000	40,800	94	1
18	450	4700	0.57	0.21	15.75	400	1.5	0.10	360,000	40,800	74	1	
20	500	9150	0.57	0.20	17.50	444	1.2	0.083	713,000	80,800	119	1	

Class 1500 (PN 260) Figure No. 1570Y, 2070Y

2.5	65	195	0.44	0.12	0.02	2.25	57.2	1.0	0.069	12,200	1,380	123	1
3	80	245	0.52	0.17	0.05	2.75	69.9	0.60	0.041	12,200	1,380	82	1
4	100	225	0.57	0.22		3.62	91.9	0.70	0.048	12,200	1,380	47	1
6	150	970	0.51	0.16		5.37	136	0.90	0.062	56,800	6,430	100	1
8	200	1650	0.51	0.16		7.00	178	0.90	0.062	97,000	11,000	101	2
10	250	2400	0.54	0.18		8.75	222	0.90	0.062	145,000	16,400	96	2
12	300	3450	0.53	0.17		10.37	263	1.1	0.076	233,000	26,400	110	1
14	350	3400	0.56	0.20		11.37	289	1.2	0.083	233,000	26,400	92	1
16	400	5050	0.57	0.20		13.00	330	1.3	0.090	360,000	40,800	108	1
18	450	4900	0.56	0.20	14.62	371	1.4	0.097	360,000	40,800	86	1	
24	600	10,500	0.56	0.20	19.62	498	1.5	0.10	824,000	93,400	109	1	

See note following section 2.4.1 for discussion of C factor.

¹ Crack open pressure drop ΔP_{co} values are generally less than 0.25 psi (0.01 bar).

Table 4 (continued) – Edward Cast Steel Tilting Disk Check Valve Flow Coefficients¹

Black numerals are in U.S. customary units or dimensionless
Colored numerals are in metric units

Size		Check Valve Flow Coefficients					Check Valve Coefficients					Perf. Curves Fig. 19
NPS	DN	C _v	F _L	x _T	K _i	d		ΔP _{FL}	SP _{FL}		C	

Class 2500 (PN 420) Figure No. 2570Y, 4470Y

2.5	65	125	0.47	0.13	0.01	1.87	47.5	2.4	0.17	12,200	1,380	178	1
3	80	195	0.44	0.12		2.25	57.2	1.0	0.069	12,200	1,380	123	1
4	100	245	0.57	0.20		2.87	72.9	0.60	0.041	12,200	1,380	75	1
6	150	655	0.50	0.15	0.05	4.37	111	0.40	0.028	26,500	3,000	71	1
8	200	990	0.57	0.20		5.75	146	0.80	0.055	56,700	6,420	87	2
10	250	1650	0.54	0.18		7.25	184	0.90	0.062	97,000	11,000	94	2
12	300	2400	0.53	0.17		8.62	219	0.50	0.034	156,000	17,700	107	1
14	350	3250	0.47	0.14		9.50	241	1.3	0.090	233,000	26,400	131	1
16	400	3450	0.57	0.20		10.87	276	1.1	0.076	233,000	26,400	100	1
18	450	5050	0.51	0.16		12.25	311	1.3	0.090	360,000	40,800	122	1
20	500	5000	0.56	0.20		13.50	343	1.3	0.090	360,000	40,800	101	1

Class 4500 (PN 760) Figure No. 4570Y, 5070Y Check valves

6	150	420	0.43	0.11	.03	3.76	95.5	0.70	0.048	21,900	2480	79	1
8	200	675	0.45	0.12		4.75	121	0.8	0.055	37,000	4190	84	1

See note following section 2.4.1 for discussion of C factor.

¹ Crack open pressure drop ΔP_{co} values are generally less than 0.25 psi (0.01 bar).

Figure 19 – Tilting Disk Check Valve Performance Curves

Figure 19A

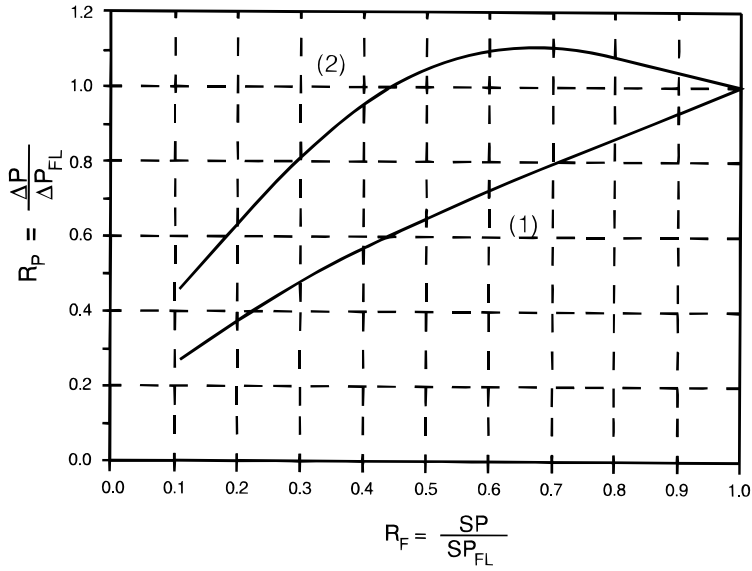

Figure 19B

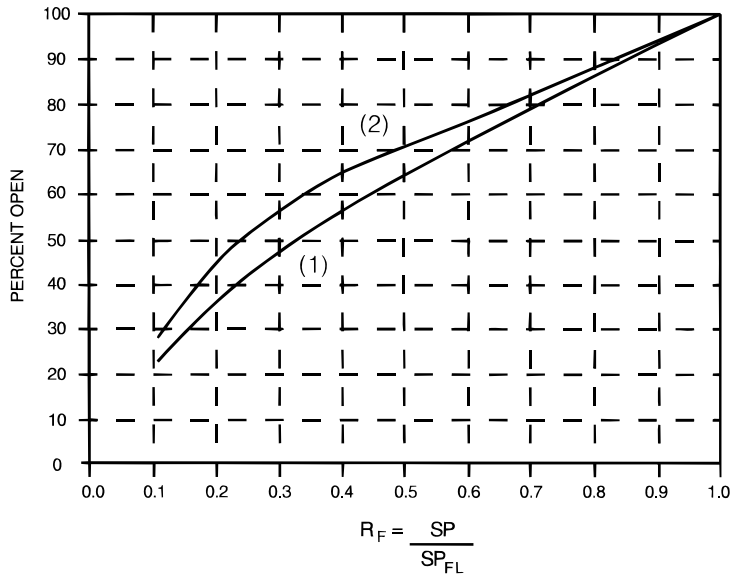

Table 5 – Edward Cast Steel Equiwedge® Gate Valve Flow Coefficients

Black numerals are in U.S. customary units or dimensionless
Colored numerals are in metric units

Regular Port Gate Valves							
Size		C _v	F _L	X _T	K _i	d	
NPS	DN						

Class 600 (PN 110) Figure No. A1611 Stop valves

2.5	65	395	0.74	0.23	0.02	2.50	63.5
3.0	80	325	0.57	0.19	0.02	3.00	76.2
4.0	100	545	0.58	0.20	0.03	4.00	102
6.0	150	2350	0.38	0.08	0.02	6.00	152

Class 900 (PN 150) Figure No. A1911, Stop valves

2.5	65	270	0.88	0.33	0.02	2.25	57.2
3.0	80	340	0.60	0.20	0.03	2.87	72.9
4.0	100	570	0.40	0.18	0.02	3.87	98.2

Regular Port Gate Valves							
Size		C _v	F _L	X _T	K _i	d	
NPS	DN						

Class 600 (PN 110) Figure No. 1611/ 1611Y, 1711Y Stop valves

2.5	65	380	0.77	0.25	0.02	2.50	63.5
3.0	80	610	0.44	0.10	0.02	3.00	76.2
4.0	100	1250	0.41	0.08	0.03	4.00	102
6.0	150	3250	0.40	0.07	0.02	6.00	152
8.0	200	5300	0.35	0.06	0.02	7.87	200
10.0	250	8550	0.34	0.06	0.01	9.75	248
12.0	300	12,000	0.31	0.05	0.01	11.75	298
14.0	350	14,000	0.32	0.05	0.01	12.87	327
16.0	400	18,500	0.32	0.05	0.01	14.75	375
18.0	450	25,500	0.30	0.05	0.01	16.50	419
20.0	500	30,500	0.31	0.05	0.01	18.25	464
22.0	550	36,500	0.30	0.05	0.01	20.12	511
24.0	600	46,500	0.30	0.05	0.01	22.00	559
26.0	650	53,500	0.30	0.05	0.01	23.75	603
28.0	700	62,500	0.29	0.04	0.01	25.50	648
—	—	—	—	—	—	—	—
—	—	—	—	—	—	—	—

Regular Port Gate Valves							
Size		C _v	F _L	X _T	K _i	d	
NPS	DN						

Class 600 (PN 110) Figure No. A1611Y Stop valves

2.5	65	385	0.76	0.25	0.02	2.50	63.5
3.0	80	365	0.55	0.16	0.02	2.90	73.7
4.0	100	625	0.53	0.16	0.03	3.83	97.3
6.0	150	2350	0.41	0.09	0.02	5.75	146

Class 900 (PN 150) Figure No. A1911Y Stop valves

2.5	65	280	0.75	0.24	0.02	2.12	53.8
3.0	80	400	0.61	0.18	0.03	2.62	66.5
4.0	100	670	0.54	0.15	0.02	3.62	91.9

Venturi Port Gate Valves							
Size		C _v	F _L	X _T	K _i	d	
NPS	DN						

Class 600 (PN 110) Figure No. 1611BY, 1711BY Stop valves

—	—	—	—	—	—	—	—
—	—	—	—	—	—	—	—
—	—	—	—	—	—	—	—
—	—	—	—	—	—	—	—
8x6x8	200x150x200	2650	0.33	0.07	0.03	7.87	200
10x8x10	250x200x250	4500	0.32	0.07	0.02	9.75	248
12x10x12	300x250x300	7100	0.32	0.06	0.02	11.75	298
14x12x14	350x300x350	9900	0.32	0.06	0.02	12.87	327
16x14x16	400x350x400	12,000	0.31	0.06	0.02	14.75	375
18x16x18	450x400x450	17,500	0.29	0.05	0.01	16.50	419
20x18x20	500x450x500	22,000	0.30	0.06	0.02	18.25	464
22x20x22	550x500x550	29,000	0.28	0.05	0.01	20.12	511
24x20x24	600x500x600	24,500	0.30	0.06	0.02	22.00	559
26x22x26	650x550x650	30,000	0.30	0.06	0.02	23.75	603
28x24x28	700x600x700	40,500	0.29	0.05	0.01	25.50	648
30x26x30	750x650x750	46,500	0.29	0.05	0.01	27.37	695
32x28x32	800x700x800	52,000	0.30	0.05	0.01	29.25	743



Table 5 (continued) – Edward Cast Steel Equiwedge® Gate Valve Flow Coefficients

Black numerals are in U.S. customary units or dimensionless
Colored numerals are in metric units

Regular Port Gate Valves							
Size		C _v	F _L	X _T	K _i	d	
NPS	DN						

Class 900 (PN 150) Figure No. 1911/ 1911Y, 14311Y Stop valves

2.5	65	380	0.63	0.17	0.02	2.25	57.2
3.0	80	455	0.44	0.11	0.03	2.87	72.9
4.0	100	990	0.42	0.09	0.02	3.87	98.2
6.0	150	2350	0.41	0.09	0.02	5.75	146
8.0	200	4200	0.37	0.07	0.02	7.50	190
10.0	250	6250	0.40	0.08	0.02	9.37	238
12.0	300	9500	0.36	0.07	0.02	11.12	282
14.0	350	12,000	0.35	0.06	0.02	12.25	311
16.0	400	15,000	0.35	0.06	0.02	14.00	356
18.0	450	19,500	0.33	0.06	0.02	15.75	400
20.0	500	26,000	0.35	0.06	0.02	17.50	444
22.0	550	28,000	0.38	0.07	0.02	19.25	489
24.0	600	38,000	0.32	0.05	0.01	21.00	533
26.0	650	45,000	0.32	0.05	0.01	22.75	578
28.0	700	52,500	0.31	0.05	0.01	24.50	622
—	—	—	—	—	—	—	—
—	—	—	—	—	—	—	—

Class 1500 (PN 260) Figure No. 11511/11511Y, 12011Y Stop valves

2.5	65	305	0.78	0.26	0.02	2.25	57.2
3.0	80	420	0.52	0.14	0.03	2.75	69.9
4.0	100	760	0.47	0.12	0.03	3.62	91.9
6.0	150	1650	0.54	0.15	0.04	5.37	136
8.0	200	3150	0.48	0.12	0.03	7.00	178
10.0	250	5500	0.40	0.08	0.02	8.75	222
12.0	300	6850	0.42	0.09	0.02	10.37	263
14.0	350	9700	0.40	0.08	0.02	11.37	289
16.0	400	12,000	0.39	0.08	0.02	13.00	330
18.0	450	15,000	0.37	0.07	0.02	14.62	371
20.0	500	18,500	0.37	0.07	0.02	16.37	416
22.0	550	23,000	0.37	0.07	0.02	18.00	457
24.0	600	27,000	0.37	0.08	0.02	19.62	498
—	—	—	—	—	—	—	—
—	—	—	—	—	—	—	—

Venturi Port Gate Valves							
Size		C _v	F _L	X _T	K _i	d	
NPS	DN						

Class 900 (PN 150) Figure No. 1911BY, 14311BY Stop valves

—	—	—	—	—	—	—	—
—	—	—	—	—	—	—	—
—	—	—	—	—	—	—	—
—	—	—	—	—	—	—	—
8x6x8	200x150x200	2000	0.37	0.09	0.03	7.50	190
10x8x10	250x200x250	3500	0.35	0.08	0.02	9.37	238
12x10x12	300x250x300	5950	0.35	0.08	0.02	11.12	282
14x12x14	350x300x350	7700	0.39	0.09	0.03	12.25	311
16x14x16	400x350x400	10,000	0.35	0.07	0.02	14.00	356
18x16x18	450x400x450	14,000	0.32	0.06	0.02	15.75	400
20x18x20	500x450x500	18,000	0.32	0.06	0.02	17.50	444
22x20x22	550x500x550	25,000	0.31	0.06	0.02	19.25	489
24x20x24	600x500x600	23,000	0.31	0.06	0.02	21.00	533
26x22x26	650x550x650	28,000	0.31	0.06	0.02	22.75	578
28x24x28	700x600x700	33,500	0.31	0.06	0.02	24.50	622
30x26x30	750x650x750	38,000	0.32	0.06	0.02	26.25	667
32x28x32	800x700x800	48,000	0.29	0.05	0.01	28.00	711

Class 1500 (PN 260) Figure No. 11511BY, 12011BY Stop valves

—	—	—	—	—	—	—	—
—	—	—	—	—	—	—	—
—	—	—	—	—	—	—	—
—	—	—	—	—	—	—	—
8x6x8	200x150x200	1650	0.43	0.12	0.04	7.00	178
10x8x10	250x200x250	2950	0.41	0.11	0.03	8.75	222
12x10x12	300x250x300	4500	0.40	0.10	0.03	10.37	263
14x12x14	350x300x350	7050	0.37	0.08	0.02	11.37	289
16x14x16	400x350x400	8700	0.37	0.08	0.02	13.00	330
18x16x18	450x400x450	11,000	0.37	0.08	0.02	14.62	371
20x18x20	500x450x500	13,500	0.36	0.08	0.02	16.37	416
22x20x22	550x500x550	18,000	0.34	0.07	0.02	18.00	457
24x20x24	600x500x600	17,000	0.35	0.07	0.02	19.62	498
26x22x26	650x550x650	20,500	0.35	0.07	0.02	21.25	540
28x24x28	700x600x700	24,000	0.36	0.08	0.02	23.00	584

Table 5 (continued) – Edward Cast Steel Equiwedge® Gate Valve Flow Coefficients

Black numerals are in U.S. customary units or dimensionless
Colored numerals are in metric units

Regular Port Gate Valves						
Size		C _v	F _L	X _T	K _i	d
NPS	DN					

Class 2500 (PN 420) Figure No. 12511/ 12511Y, 14411Y Stop valves

2.5	65	150	0.78	0.50	0.02	1.87	47.5
3.0	80	230	0.58	0.18	0.04	2.25	57.2
4.0	100	340	0.59	0.19	0.04	2.87	72.9
6.0	150	910	0.61	0.19	0.05	4.37	111
8.0	200	1850	0.51	0.14	0.04	5.75	146
10.0	250	2950	0.48	0.12	0.03	7.25	184
12.0	300	4350	0.46	0.11	0.03	8.62	219
14.0	350	5150	0.47	0.12	0.03	9.50	241
16.0	400	7050	0.46	0.11	0.03	10.87	276
18.0	450	8950	0.46	0.11	0.03	12.25	311
20.0	500	11,500	0.45	0.11	0.03	13.50	343
22.0	550	14,000	0.45	0.11	0.03	14.87	378
24.0	600	17,500	0.43	0.10	0.03	16.25	413
—	—	—	—	—	—	—	—
—	—	—	—	—	—	—	—

Venturi Port Gate Valves						
Size		C _v	F _L	X _T	K _i	d
NPS	DN					

Class 2500 (PN 420) Figure No. 12511B/ 12511BY, 14411BY Stop valves

—	—	—	—	—	—	—	—
—	—	—	—	—	—	—	—
—	—	—	—	—	—	—	—
—	—	—	—	—	—	—	—
8x6x8	200x150x200	1000	0.44	0.12	0.04	5.75	146
10x8x10	250x200x250	1650	0.46	0.14	0.04	7.25	184
12x10x12	300x250x300	2750	0.43	0.11	0.03	8.62	219
14x12x14	350x300x350	3900	0.46	0.13	0.03	9.50	241
16x14x16	400x350x400	4850	0.44	0.12	0.03	10.87	276
18x16x18	450x400x450	6450	0.43	0.11	0.03	12.25	311
20x18x20	500x450x500	8200	0.44	0.12	0.03	13.50	343
22x20x22	550x500x550	11,500	0.39	0.10	0.03	14.87	378
24x20x24	600x500x600	10,500	0.39	0.10	0.03	16.25	413
26x22x26	650x550x650	13,000	0.39	0.09	0.02	17.62	448
28x24x28	700x600x700	16,000	0.39	0.09	0.03	19.00	483

Figure 21 – Ratio of Specific heats (k) for some gasses

k = 1.3	Ammonia	Carbon Dioxide	Dry Steam	Methane	Natural Gas
k = 1.4	Air	Carbon Monoxide	Hydrogen	Nitrogen	Oxygen

Figure 22A – Saturated Water - Temperature, Pressure & Density (U.S. Units)

Water Temp. °F	32	70	100	200	300	400	500	550	600	650	700	705
Vapor Pressure, p _v	0.09	0.36	0.95	11.5	67	247	681	1045	1543	2208	3094	3206
Water Density, ρ	62.4	62.3	62.0	60.1	57.3	53.7	49.0	46.0	42.3	37.4	27.3	19.7

P = Pressure in psia, ρ = Density in lb/ft³

Figure 22B – Saturated Water - Temperature, Pressure & Density (Metric)

Water Temp. °C	0	25	50	100	150	200	250	300	350	370	374
Vapor Pressure, p _v	.006	.032	.123	1.01	4.76	15.6	39.8	85.9	165.4	211	221
Water Density, ρ	1000	997	988	958	917	865	799	712	574	452	315

P = Pressure in Bar Absolute, ρ = Density in kg/m³

Figure 22 – Density of Steam

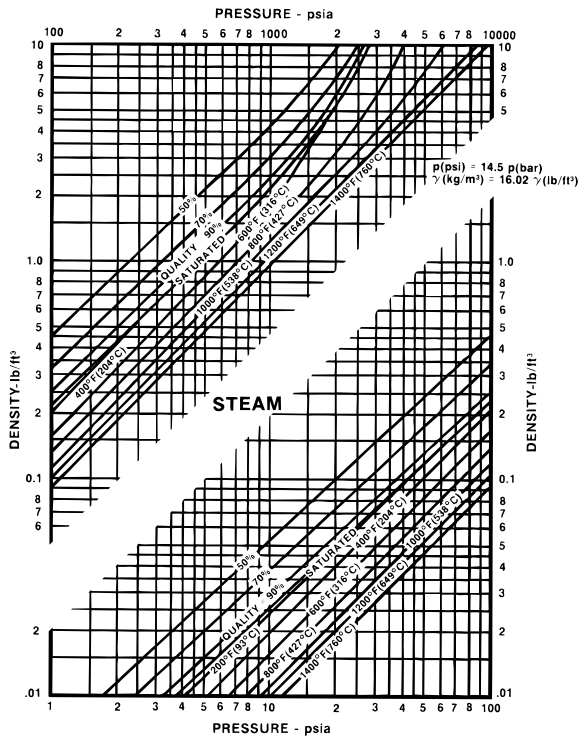

Figure 23 – Density of Air

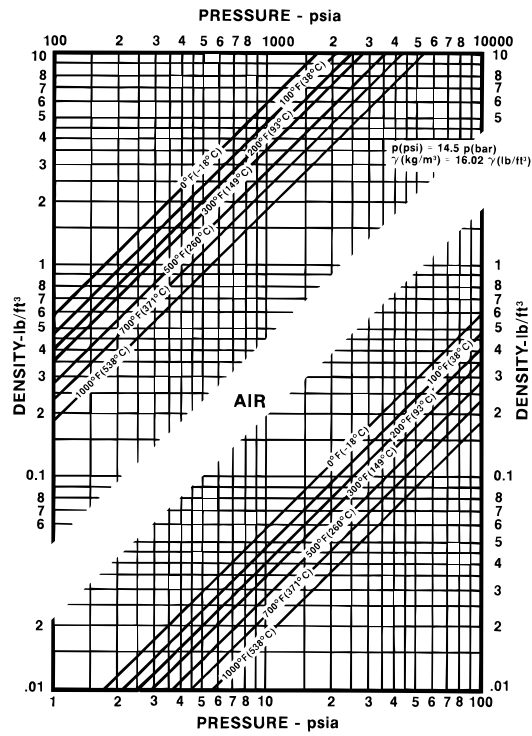
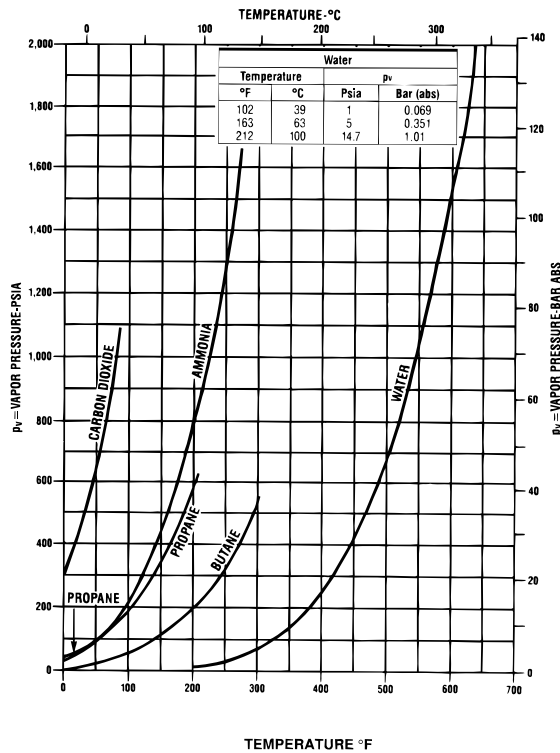

Figure 24 – Vapor Pressure of Liquid



Conversion of Measurement Units

Length

1 in. = 25.4 mm 1 mile = 5280 ft
 1 in. = 2.54 cm 1 mile = 1.609 km
 1 in. = 0.0254 m 1 km = 3281 ft
 1 ft = 0.3048 m 1 m = 39.37 in.

Area

1 in.² = 645.2 mm² 1 m² = 10.76 ft²
 1 in.² = 6.452 cm² 1 m² = 1550 in.²
 1 ft² = 144 in.²

Volume

1 in.³ = 16.39 cm³ 1 m³ = 35.31 ft³
 1 ft³ = 1728 in.³ 1 m³ = 264.2 U.S. gal.
 1 U.S. gal. = 231 in.³ 1 m³ = 220 Imp. gal.
 1 U.S. gal. = 0.1337 ft³ 1 m³ = 1000 liters
 1 U.S. gal. = 0.8327 Imp. gal.
 1 U.S. gal. = 3.7854 liters
 1 liter = 1000 cm³
 1 ft³ = 28.32 liters 1 ml = 1 cm³

Density

1 lb/ft³ = 16.02 kg/m³
 1 lb/ft³ = 0.01602 g/cm³
 1 lb/in³ = 1728 lb/ft³
 density = specific gravity x reference density
 density = 1/specific volume

Specific Volume

specific volume = 1/density

Temperature

T(°C) = T(°F - 32) / 1.8
 T(°F) = 1.8 T(°C) + 32
 T(°R) = T(°F) + 460
 T(°K) = T(°C) + 273
 T(°R) = 1.8 T(°K)

where:

°C = degrees Celsius
 °F = degrees Fahrenheit
 °K = degrees Kelvin (absolute temperature)
 °R = degrees Rankine (absolute temperature)

Specific Gravity – Liquids

$$G_l = \frac{\text{density of liquid}}{\text{density of water at reference condition}}$$

Commonly used relations are:

$$G_l = \frac{\text{density of liquid}}{\text{density of water at 60°F and atmospheric pressure}}$$

$$G_l = \frac{\rho \text{ (lb/ft}^3\text{)}}{62.38 \text{ (lb/ft}^3\text{)}}$$

$$G_l = \frac{\text{density of liquid}}{\text{density of water at 4°C and atmospheric pressure}}$$

$$G_l = \frac{\rho \text{ (kg/m}^3\text{)}}{1000 \text{ (kg/m}^3\text{)}}$$

For practical purposes, these specific gravities may be used interchangeably, as the reference densities are nearly equivalent.

Specific gravities are sometimes given with two temperatures indicated, e.g.,

$$G_{l, 60^\circ\text{F} / 60^\circ\text{F}}, G_{l, 15.5^\circ\text{C} / 4^\circ\text{C}}, G_{l, 60^\circ\text{F} / 60^\circ}$$

The upper temperature is that of the liquid whose specific gravity is given, and the lower value indicates the water temperature of the reference density. If no temperatures are shown, assume that the commonly used relations apply.

For petroleum liquids having an “API degrees” specification:

$$G_{l, 60^\circ\text{F} / 60^\circ} = \frac{141.5}{131.5 + \text{API degrees}}$$

Pressure

1 Mpa = 145 psi 1 psi = 6895 Pa
 1 pond = 1 gf 1 psi = 6895 N/m²
 1 std atm = 14.696 psi 1 Pa = 1 N/m²
 1 std atm = 1.0133 bar 1 bar = 14.50 psi
 1 std atm = 1.0133 x 10⁵ N/m² 1 bar = 100,000 N/m²
 1 kgf/cm² = 14.22 psi
 1 std atm = 760 torr absolute pressure = gage pressure + atmospheric pressure

Specific Gravity – Gases

$$G_g = \frac{\text{density of gas (at pressure and temperature of interest)}}{\text{density of air (at same pressure and temperature)}}$$

Because the relation between density, pressure and temperature does not always behave in an ideal way (i.e., ideally, density is proportional to pressure divided by temperature, in absolute units), use of the above relation requires that the pressure and temperature of interest be specified. This means that the specific gravity of a gas as defined may vary with pressure and temperature (due to “compressibility” effects).

Frequently, specific gravity is defined using:

$$G_g = \frac{\text{molecular weight of gas}}{\text{molecular weight of air}} = \frac{M_w}{28.96}$$

If this relation is used to calculate density, one must be careful to consider “compressibility” effects.

When the pressure and temperature of interest are at or near “standard” conditions (14.73 psia, 60°F) or “normal” conditions (1.0135 bar abs, 0°C), specific gravities

calculated from either of the above relations are essentially equal.

Pressure Head

1 foot of water at 60°F = 0.4332 psi

$$p \text{ (psi)} = \frac{\rho \text{ (lb/ft}^3\text{)} \times h \text{ (feet of liquid)}}{144}$$

$$p \text{ (N/m}^2\text{)} = \frac{\rho \text{ (kg/m}^3\text{)} \times h \text{ (meters of liquid)}}{0.1020}$$

$$p \text{ (bar)} = \frac{\rho \text{ (kg/m}^3\text{)} \times h \text{ (meters of liquid)}}{10200}$$

1 meter of water at 20°C = 9.790 kN/m²
 1 meter of water at 20°C = 97.90 mbar
 1 meter of water at 20°C = 1.420 psi

Flow Rate

• mass units
 1 lb/hr = 0.4536 kg/hr
 1 metric tonne/hr = 2205 lb/hr

• liquid volume units
 1 U.S. gpm = 34.28 BOPD
 BOPD = barrels oil per day
 1 U.S. gpm = 0.8327 Imp. gpm
 1 U.S. gpm = 0.2273 m³/hr
 1 U.S. gpm = 3.785 liters/min
 1 m³/hr = 16.68 liters/min
 1 ft³/s = 448.8 U.S. gpm

• mixed units
 w(lb/hr) = 8.021 q(U.S. gpm) x ρ(lb/ft³)
 w(lb/hr) = 500 q(U.S. gpm of water at 70°F or less)

In the following:

STP (standard conditions) refers to 60°F, 14.73 psia

NTP (normal conditions) refers to 0°C, 1.0135 bar abs

$$G_g = \frac{\text{molecular weight of gas}}{\text{molecular weight of air}} = \frac{M_w}{28.96}$$

w(lb/hr) = 60 q(scfm of gas) x ρ(lb/ft³) at STP
 w(lb/hr) = q(scfh of gas) x ρ(lb/ft³) at STP
 w(lb/hr) = 4.588 q(scfm of gas) x G_g
 w(lb/hr) = 0.07646 q(scfh of gas) x G_g
 w(lb/hr) = 3186 q(MMscfd of gas) x G_g
 Mmscfd = millions of standard cubic feet per day
 w(kg/hr) = q(normal m³/hr of gas) x ρ(kg/m³ at NTP)
 w(kg/hr) = 1.294 q(normal m³/hr of gas) x G_g

3. Edward Valve Design Standards and Features

Engineering and research efforts – both analytical and experimental – have contributed to innovative leadership by Flowserve Edward Valves through the introduction or practical development of some major industrial valving features:

- Integral hardfaced seats in globe and angle valves to permit compact valve designs and to resist erosion and wear.
- Impactor handwheels and handles to permit tight shutoff of manually operated globe and angle valves.
- Body-guided globe and angle valve disks to minimize wear and ensure alignment with seats for tight sealing.
- Inclined-bonnet globe valves with streamlined flow passages to minimize pressure drop due to flow.
- Equalizers for large check and stop-check valves to ensure full lift at moderate flow rates and to prevent damage due to instability.
- Compact pressure-seal bonnet joints to eliminate massive bolted flanges on large, high-pressure valves:
 - First with wedge-shaped metal gaskets with soft coatings, optimized over more than four decades to provide tight sealing in most services.
 - Now, for the severest services, with composite gaskets using flexible graphite and special anti-extrusion rings to ensure tight sealing, even with severe temperature transients – overcomes need for field re-tightening and eases disassembly for maintenance.
- Optimized stem-packing chambers and packing-material combinations to ensure tight stem sealing:
 - First with asbestos-based materials and then with asbestos-free materials.
- Hermetically sealed globe valves with seal-welded diaphragm stem seals to prevent stem leakage in critical applications, including nuclear.
- Gate valves with flexible double-wedge construction to ensure tight sealing at both low and high pressures and to prevent sticking difficulties when opening.

- Qualified stored-energy actuators for quick-closing valves in safety-related nuclear-plant applications – and qualified valve-actuator combinations that are used in main-steam isolation service throughout the world.

Flowserve valve expertise, acquired over more than 85 years, is shared with national and international codes-and-standards committees and other technical societies and groups whose activities influence industrial valves. This cooperation has included participation in the development of every issue of ASME/ANSI B16.34 as well as most issues of ASME/ANSI B16.5 (Pipe Flanges and Flanged Fittings), which applied to steel valves before ASME/ANSI B16.34 was first issued in 1973. Flowserve representatives have also been active in preparation of ISO (International Standards Organization) standards. In addition, Flowserve representatives have participated where appropriate with trade organizations such as EPRI, INPO and various nuclear power-plant owners' groups in addressing valve issues.

3.1 Codes and Standards

Flowserve Edward valves are designed, rated, manufactured and tested in accordance with the following standards where applicable:

- ASME B16.34-2004 – Valves: flanged, threaded and welding end.
- ASME/ANSI B16.10-2000– Face-to-face and end-to-end dimensions of valves.
- ASME B16.11 – Forged Fittings, Socket-welding and Threaded.
- ASME Boiler and Pressure-Vessel Code – Applicable sections including Nuclear Section III.
- ASME and ASTM Material Specifications – Applicable sections.
- MSS Standard Practices – Where appropriate: Edward sealability acceptance criteria are equal to or better than those in MSS SP-61.

Users should note that ASME/ANSI B16.34-2004 has a much broader scope than the previous editions. While this standard previously covered only flanged-end and butt welding-end valves, the 1988 edition covered socket welding-end and threaded-end valves as well. With this revision, the standard now

addresses practically all types, materials and end configurations of valves commonly used in pressure-piping systems. All Edward valves in this catalog with a listed class number (e.g. Class 1500) comply with ASME B16.34.

In addition to the standards listed, special requirements such as those of API and NACE are considered on application.

3.2 Pressure Ratings

Flowserve Edward valve-pressure ratings are tabulated in pressure-versus-temperature format. The temperatures range from -20°F (-29°C) to the maximum temperature permitted for each specific design and pressure-boundary material. Typically, pressure ratings decrease with increasing temperature, approximately in proportion to decreases in material strength.

Valves in this catalog with a listed class number are rated in accordance with ASME B16.34-2004. This standard establishes allowable working pressure ratings for each class number and material. These ratings also vary with class definitions as described below.

Standard Class (Ref: Paragraph 2.1.2 of ASME B16.34-2004) – These lowest ratings apply to all flanged-end valves as well as any threaded-end or welding-end valves that do not meet the requirements for other classes. Typically, ratings for these valves are consistent with ratings listed for flanges and flanged fittings of similar materials in ASME/ANSI B16.5-2003.

Special Class (Ref: Paragraph 2.1.3 of ASME B16.34-2004) – These ratings apply to threaded-end or welding-end valves which meet all requirements for a Standard Class rating and in addition meet special nondestructive examination (NDE) requirements. Valve bodies and bonnets are examined by volumetric and surface examination methods and upgraded as required. Pressure ratings for Special Class valves are higher than those for Standard Class valves (particularly at elevated temperatures) because of the improved assurance of soundness of pressure boundaries and because they are not subject to the limitations of flanged and gasketed end joints.

Limited Class (Ref: Paragraph 2.1.3 of ASME B16.34-2004) – These ratings apply only to threaded-end or welding-end valves in sizes 2-½ and smaller, with generally cylindrical, internal-wetted pressure boundaries. Limited Class valves meet all requirements for Standard Class valves, and body designs must also satisfy special reinforcement rules to compensate for irregularities in shape. Typically, the regions of minimum wall thickness in these valves are very localized, so minor plasticity in such regions at high temperature will not adversely affect valve geometry. Pressure ratings for Limited Class valves are the same as those for Special Class valves at lower temperatures, but Limited Class ratings are higher at very high temperatures [above 900°F (482°C) for ferritic steels and above 1050°F (565°C) for austenitic steels].

It should be understood that flanged-end valves can be supplied only as Standard Class valves with numerically even pressure-class designations (300, 600, 900, 1500, 2500), for consistency with mating flanges in piping systems. Threaded-end or welding-end valves can be supplied with the same designations or as Class 4500 (for which there is no standard for flanged-end connections). In addition, threaded-end or welding-end valves can be furnished with intermediate ratings or class designations (ref: paragraph 2.1.4 of ASME B16.34-2004), up to Class 2500 for threaded ends and up to Class 4500 for welding-ends. For example, Class 2680 welding-end Univalves, can be applied in superheater-drain applications that could not be satisfied with a Class 2500 valve rating.

Series or CWP

A few valves in this catalog with “Series” or “CWP” designations are designed, rated, manufactured and tested to Flowserve Edward Valves proprietary standards. These valve designs, qualified by decades of successful field performance, will provide safe and reliable service in applications where an ASME/ANSI rating is not required by a piping code or other specifications.

These valve designs and ratings are generally, but not completely, in conformance with recognized national standards (e.g., some employ high-strength materials not listed in standards). These valves have a history of excellent performance and safety, and they may be applied with confidence in applications where ASME/ANSI ratings are not required.

Notes:

1. While Edward cast-steel valves described in this catalog have even listed ratings (e.g., 1500), many designs provide more wall thickness than required in critical areas. Accordingly, welding-end valves can often be offered with intermediate ratings (ref: Paragraph 6.1.4 of ASME B16.34-2004) moderately higher than the nominal class ratings. With appropriate revisions to testing procedures, this can allow somewhat higher pressure ratings than those listed in the tabulations. Consult Edward Valves and provide information on specific required design pressure and temperature conditions.

2. Pressure ratings for carbon steel (A105 and A216 WCB) valves are tabulated for temperatures through 1000°F (538°C), which is consistent with ASME B16.34-2004. As noted in that standard, these materials are permissible but not recommended for prolonged usage at above about 800°F (427°C). This precaution is related to the possibility that carbides in carbon steel may be converted to graphite.

3. Other codes or standards applicable to piping systems may be more restrictive than ASME B16.34-2004 in limiting allowable pressures for valves. For example, ASME B31.1-1995 (Power Piping) does not permit use of carbon steel (A105 and A216 WCB) at design temperatures above 800°F (427°C). Users must consider all codes or regulations applicable to their systems in selecting Edward Valves.

4. The maximum tabulated temperatures at which pressure ratings are given for Edward valves are in some cases less than the maximum temperatures given in ASME B16.34-2004 for valves of the same material. The maximum tabulated temperatures in this catalog may reflect limitations of materials used for other valve parts (e.g., stems). Use of Edward valves at temperatures above the maximum tabulated values may result in degradation and is not recommended.

3.3 Pressure-Seal Construction

The time-proven Edward pressure-seal bonnet seals more effectively as pressure increases, because the pressure forces the sealing elements into closer contact. Metal pressure-seal gaskets with soft plating employ optimum contact angles and materials for each applicable valve type, size and pressure-class rating. The gaskets yield initially

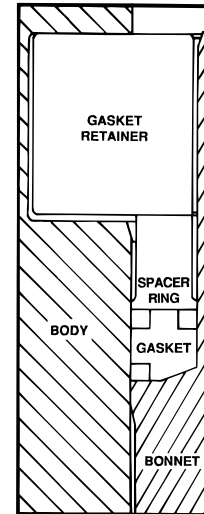

Composite Pressure-Seal Construction

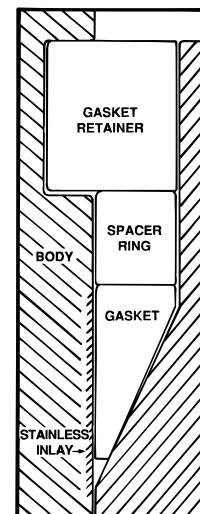

Typical Pressure-Seal Construction

under bolting load and then under pressure, to provide excellent sealing contact.

New designs for highest pressure/temperature services employ improved composite pressure-seal gaskets with flexible graphite rings. Flowserve leadership in proof-testing of Edward Valves flexible graphite stem packings clearly showed the superior sealing characteristics of this material, and continued research led to the development of a test-proven bonnet closure that provides highest sealing integrity. The composite pressure-seal provides excellent sealing at low and high pressures, even under severe pressure/temperature transients. It provides easier disassembly for maintenance, seals over minor scratches and does not depend on retightening under pressure after reassembly.

3.4 Hardfacing

Integrity of seating surfaces on bodies, wedges and disks in gate, globe, and check valves is essential for tight shutoff. Valve body seats must be hardfaced, and wedges and disks must either be hardfaced or made from an equivalent base material.

The standard seating material for most Edward valves is cobalt-based Stellite 21[®], which has excellent mechanical properties and an exceptional performance history. As compared to Stellite 6[®], which was used in many early Edward valves and is still used in many competitive valves, Stellite 21[®] is more ductile and impact resistant. These properties provide superior resistance to cracking of valve seating surfaces in service.

Stellite 21 is used either as a complete part made from a casting (as in Univalve[®] disks and small Equiwedge[®] gate valve wedges) or as a welded hardsurfacing deposit. Depending on valve size and type, hardsurfacing material is applied by a process that assures highest integrity (PTA, MIG, etc.).

While the as-deposited (or as-cast) hardness of Stellite 21 is somewhat lower than that of Stellite 6, Stellite 21 has a work-hardening coefficient that is five times that of Stellite 6. This provides essentially equivalent hardness after machining, grinding, and exposure to initial seating stresses. In addition, low friction coefficients attainable with Stellite 21 provide valuable margins in assuring valve operation with reasonable effort or actuator sizing.

The properties of Stellite 21 also provide an advantage to the user long after a valve

leaves the Edward plant. If a large valve seat is severely damaged in a localized area, as may occur due to closing on foreign objects, the seat may be repaired locally and refinished, in such cases, where a valve cannot be adequately preheated before welding, a Stellite 6 seat may crack during the repair process – requiring either removal of the valve from the line or in situ removal replacement of the complete seat.

Some Edward valves have used solid disks made of hardened ASTM A-565 Grade 616 or 615 stainless steel. This corrosion-resistant alloy has been proven in seating and erosion tests and in service. This material can be furnished in certain valves for nuclear-plant services where reduced cobalt is desirable. Similar iron-base trim materials are used in production of certain standard valves. Extensive research on other cobalt-free valve trim materials has also identified other alloys which provide good performance under many service conditions. Consult Flowserve about any special trim requirements.

® Registered Trademark – Stoddy Co.

3.5 Valve-Stem Packing

Stem sealing is an extremely important valve performance feature, since seal leakage can represent energy loss, a loss of product and a potential environmental or safety hazard. Consequently, Edward stop and stop-check valves employ stem packings that have been qualified by extensive testing.

The search for improved sealing performance was a primary reason for seeking out new stem-packing materials to replace asbestos-based packings. The demand of many valve users to discontinue use of asbestos due to health risks was an important secondary reason. Since there are no simple laboratory tests that will predict sealing performance based on measurable properties of packing materials, hundreds of tests have been necessary with various packings in valves or valve mockups.

Some packings required frequent adjustments due to wear, extrusion or breakdown, and some could not be made to seal at all after relatively brief testing. All standard Edward stop and stop-check valves now employ flexible graphite packing which provides excellent stem sealing. However, the key to its success involves retaining the graphitic material with special, braided end rings to prevent extrusion. Various end rings are used, depending on the valve pressure class

and expected service-temperature range. All Edward valves assembled since January 1986 have been asbestos-free.

See V-REP 86-2 for more information.

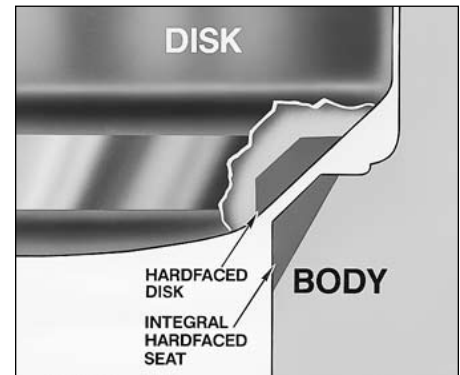



Maintenance

FLOWSERVE EDWARD VALVES ON-SITE FIELD SERVICE REPAIR CAPABILITIES

FlowsERVE is totally committed to customer service satisfaction. Our entire manufacturing operation guarantees we will stand behind all field service repair work to maximize customer support.

OUR FACILITY OFFERS

- Mobile machine shop trailer for on-site repairs
- After-hours plant-based service team for around the clock coverage
- Expertly trained field service personnel capable of handling any size field service job
- Special equipment for seat refinishing, body boring, welding, and stress relieving
- In-house valve repair and return remanufacturing to original specifications with new valve warranty
- Experience in turn-key jobs to help the customer with one stop shopping
- 180,000 Sq. Ft. manufacturing facility with state of the art machining and engineering capability and ISO 9001 certification
- FlowsERVE Raleigh is ISO 9001 certified. Approved by Lloyd's Register Quality Assurance
- FlowsERVE Raleigh is authorized by ASME to use the "NR" symbol.

**Phone Toll Free
24 Hours a Day
365 Days a Year
(Day) 1-800-225-6989
(Night) 1-800-543-3927**

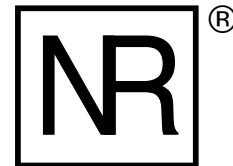



STAYING ON-LINE WITH FLOWSERVE

We design and manufacture all our valves for 40 years' life in the field. That means not just building a reliable product, but one that is easy to maintain and service. It also means providing a team of experienced, dedicated professionals to keep your Flowserve valves operating at peak performance.

Highly Experienced Technicians

Flowserve brings unmatched experience to the field. Our service technicians have an average 20 years in the industry, and 15 years with Flowserve. Each has special skills, such as welding and machining, that we can target for the needs of the individual job.

Comprehensive Record-Keeping

Our files include original specifications for every Flowserve valve sold since 1908. All valves are coded for easy identification. On new and replacement orders, Flowserve stands ready to provide the complete lot-traceability required for nuclear and other critical services.

In-Line Service

We are dedicated to on-site service whenever possible. To this end, we not only provide highly experienced, expert personnel — we also support those technicians with field equipment, including portable boring, lapping, welding, and weld-cutting machines. Major parts, such as disks or bonnets, can be air-shipped back to the factory for service and repaired while service personnel perform other tasks.

Parts Replacement

Our comprehensive record-keeping system also facilitates replacement of parts. Our computer database can quickly tell us if we have the part in stock or on order, or how we can best coordinate raw materials and factory resources for the quickest possible turnaround time.

New 90-day Warranty

On all valves repaired to Flowserve's standards, we will issue a new 90-day warranty.

Factory Repair & Upgrading

Our After-Hours Coverage Team (AHCT) specialists are on-call around the clock, seven days a week, to deliver on our commitment to provide immediate response to our customers' requirements. Whether your requirements are for a planned outage, preventive maintenance or an emergency demand, Flowserve will remanufacture or upgrade valves to the original or most current specification. Our in-house engineering and quality assurance support is committed to meet the required turn-around time.

Planned & Emergency Outages

Our service managers will coordinate scheduled maintenance, and also get technical assistance to your facility quickly for emergency needs.

This page intentionally left blank.



This page intentionally left blank.

This page intentionally left blank.

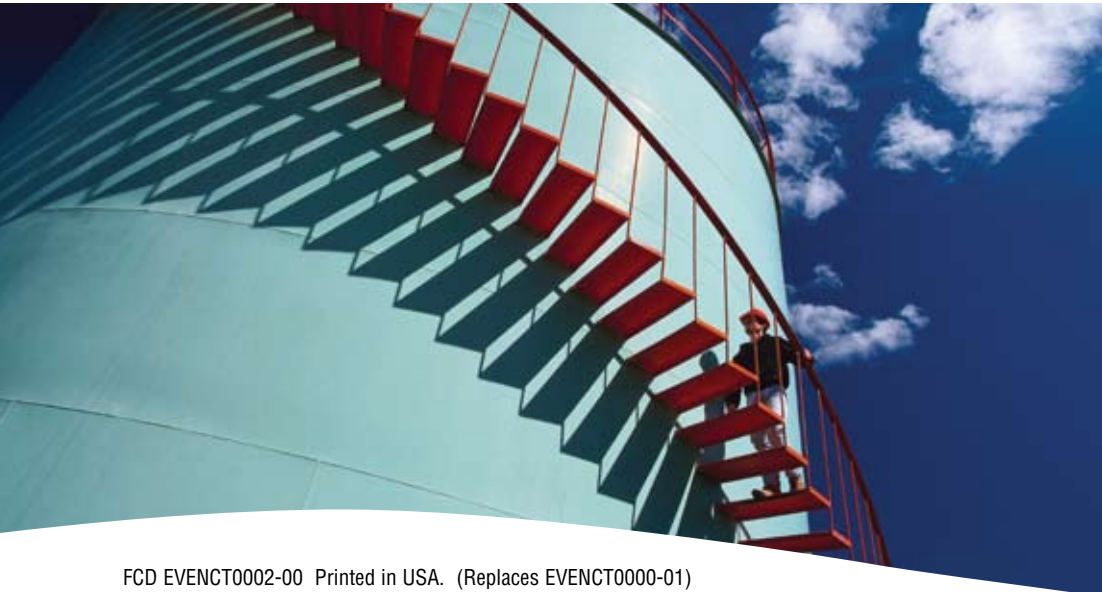

United States

Flowserve Corporation
Flow Control
1900 South Saunders Street
Raleigh, NC 27603
Telephone: +1 919 832 0525
Telefax: +1 919 831 3369

FCD EVENCT0002-00 Printed in USA. (Replaces EVENCT0000-01)

To find your local Flowserve representative:

For more information about Flowserve Corporation, visit
www.flowserve.com or call USA 1 800 225 6989

Flowserve Corporation has established industry leadership in the design and manufacture of its products. When properly selected, this Flowserve product is designed to perform its intended function safely during its useful life. However, the purchaser or user of Flowserve products should be aware that Flowserve products might be used in numerous applications under a wide variety of industrial service conditions. Although Flowserve can (and often does) provide general guidelines, it cannot provide specific data and warnings for all possible applications. The purchaser/user must therefore assume the ultimate responsibility for the proper sizing and selection, installation, operation, and maintenance of Flowserve products. The purchaser/user should read and understand the Installation Operation Maintenance (IOM) instructions included with the product, and train its employees and contractors in the safe use of Flowserve products in connection with the specific application.

While the information and specifications contained in this literature are believed to be accurate, they are supplied for informative purposes only and should not be considered certified or as a guarantee of satisfactory results by reliance thereon. Nothing contained herein is to be construed as a warranty or guarantee, express or implied, regarding any matter with respect to this product. Because Flowserve is continually improving and upgrading its product design, the specifications, dimensions and information contained herein are subject to change without notice. Should any question arise concerning these provisions, the purchaser/user should contact Flowserve Corporation at any one of its worldwide operations or offices.

© 2008 Flowserve Corporation, Irving, Texas, USA. Flowserve is a registered trademark of Flowserve Corporation.